

AN6152

Speech Network Circuit

■ Overview

The AN6152 is an integrated circuit designed for telephone speech network. It has the basic function which is necessary to apply a sound signal onto the line and excellent in branch performance.

■ Features

- Wide operating voltage range : 3 to 11.5V
- Built-in amplifiers for "Dial Tone" and "DTMF"
- Amplifier
- Each amplifier gain automatically changeable depending on line current.
- Various types of microphone and receiver are available.

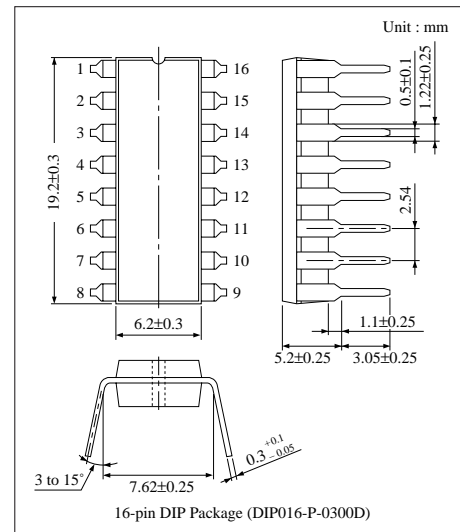

■ Block Diagram

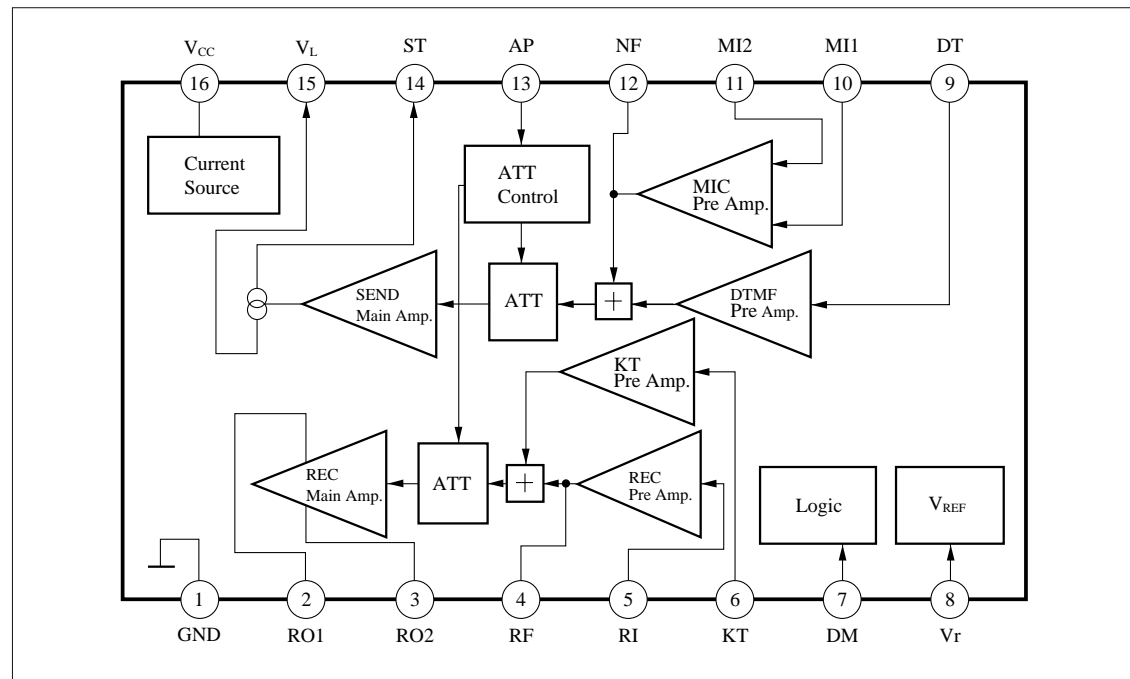

■ Pin Descriptions

Pin No.	Pin name	Pin No.	Pin name
1	GND	9	DTMF input
2	REC output	10	MIC input
3	REC output	11	MIC input
4	REC filter	12	SEND NF
5	REC input	13	ATT control
6	KEY IN TONE input	14	SIDE tone
7	DIAL mute SW	15	LINE
8	V reference	16	Internal supply voltage

■ Absolute Maximum Ratings (Ta=25°C)

Parameter	Symbol	Rating	Unit
Line voltage	V_L	14.4	V
Line current	I_L	120	mA
Power dissipation (Ta=60°C)	P_D	1380	mW
Operating ambient temperature	T_{opr}	-30 to + 75	°C
Storage temperature	T_{stg}	-55 to + 150	°C

■ Electrical Characteristics (Ta=25°C)

Parameter	Symbol	Condition	min	typ	max	Unit
Receiver System						
Receiver gain (1)	G_{V-R1}	$I_L=30mA, V_i=-50dBV$	34.5	37.5	39.5	dB
Receiver gain (2)	G_{V-R2}	$I_L=80mA, V_i=-50dBV$	31.5	34.0	36.5	dB
Max. receiver	V_{O-R}	$I_L=30mA, THD=5%$	0	5	—	dBV
KEY IN TONE gain (1)	G_{V-KT1}	$I_L=30mA, V_i=-50dBV$	28.5	31.0	33.5	dB
KEY IN TONE gain (2)*1	G_{V-KT2}	$I_L=80mA, V_i=-50dBV$	25.5	28.0	30.5	dB
Transmission System						
Transmission gain (1)	G_{V-T1}	$I_L=30mA, V_i=-50dBV$	33	35.5	38	dB
Transmission gain (2)	G_{V-T2}	$I_L=80mA, V_i=-50dBV$	29.5	32.0	34.5	dB
Max. transmission level	V_{O-T}	$I_L=30mA, THD=5%$	0	5	—	dBV
DTMF gain (1)	G_{V-DT1}	$I_L=30mA, V_i=-50dBV$	28.5	30.5	32.5	dB
DTMF gain (2)	G_{V-DT2}	$I_L=80mA, V_i=-50dBV$	25.0	27.0	29.0	dB
DTMF transmission level	V_{O-DT}	$I_L=30mA, THD=5%$	0	5	—	dBV
Power Supply						
DC line voltage (1)	V_{L-1}	$I_L=20mA$	2.6	3.1	3.6	V
DC line voltage (2)	V_{L-2}	$I_L=120mA$	7.5	9.0	10.5	V
Internal supply voltage (1)	V_{CC-1}	$I_L=20mA$	1.8	2.1	2.4	V
Internal supply (2)	V_{CC-2}	$I_L=120mA$	5.8	6.5	7.2	V
AC impedance (1)*1	Z_{AC-1}	$I_L=30mA, f_m=1kHz$	450	610	750	Ω
AC impedance (2)*1	Z_{AC-2}	$I_L=90mA, f_m=1kHz$	450	610	750	Ω

Note) Operating supply voltage range : $V_{CC(opr)} = 3$ to 11.5V

*1 These values are of reference values but not guaranteed values.

■ Electrical Characteristics (cont.) (Ta=25°C)

Parameter	Symbol	Condition	min	typ	max	Unit
Dial Mute Input						
Dial mute OFF	V_{DM-H}		0.8	—	V_{CC}	V
Dial mute ON	V_{DM-L}		—	—	0.3	V
Input current (1)	I_{DM-H}	$V_{DM}=V_{CC}$	-2.0	0.1	2.0	μA
Input current (2)	I_{DM-L}	$V_{DM}=0V$	-2.0	-0.2	-0.02	μA
REC mute *1, 2	M_{-R}	$I_L=30mA$, $V_i=-35dBV$, Dial Mute SW- ON	50	—	—	dB
KT mute *1, 2	M_{-KT}	$I_L=30mA$, $V_i=-30dBV$, Dial Mute SW- OFF	50	—	—	dB
MIC mute *1, 2	M_{-DT}	$I_L=30mA$, $V_i=-35dBV$, Dial Mute SW- ON	60	—	—	dB
DTMF mute *1, 2	M_{-DT}	$I_L=30mA$, $V_i=-30dBV$, Dial Mute SW- OFF	50	—	—	dB

Note) Operating supply voltage range : $V_{CC(oper)} = 3$ to 11.5V

*1 These values are of reference values but not guaranteed values.

*2 Measure the output signal ratio when each amp. system operates or does not operate.



LittleDiode supplies new, hard to find or obsolete electronic components and semiconductors all over the world.

With over two million different components listed you are sure to find the part you need.

Feel free to visit us today at our online store:

LittleDiode.com

Looking forward to providing you with the best possible service.