

AN6297S

Peak-Noise-Reduction System for 8mm VTRs

Outline

The AN6297S is designed for the noise reduction of an FM audio and a PCM audio for an 8 mm VTR.

Features

- Excellent matching to 8mm VTR noise-reduction characteristics.
- Includes all functions of noise-reduction system.
- Minimum number of external components.
- Low power consumption.
- Super reliable small out-line package.

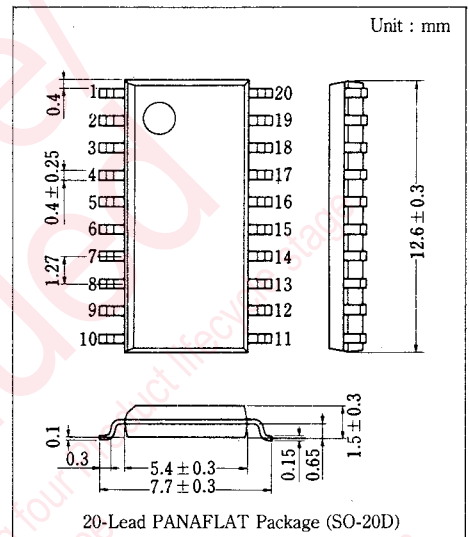

Block Diagram

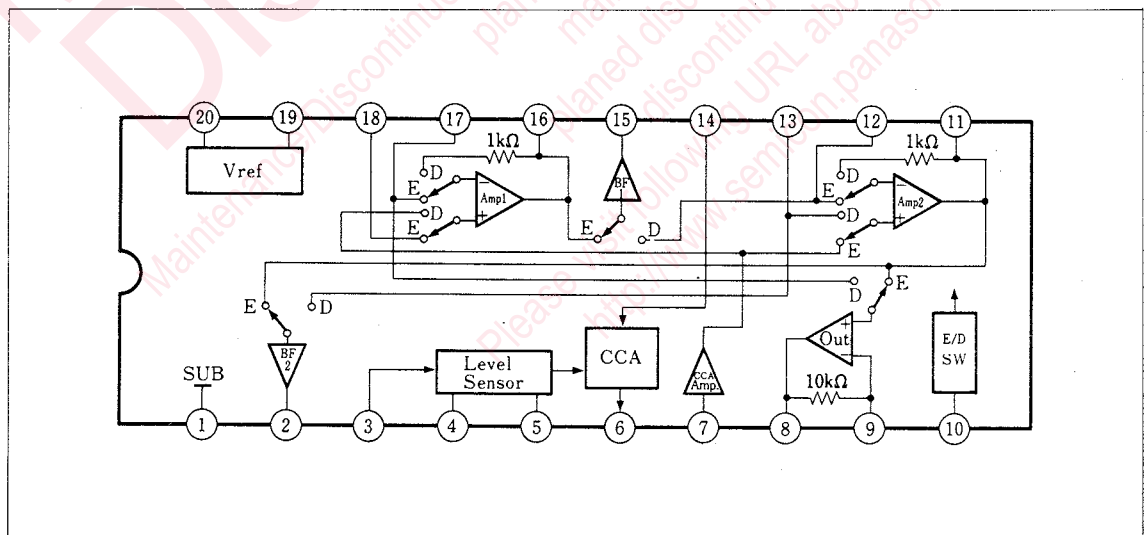

■ Absolute Maximum Ratings(Ta=25°C)

Item	Symbol	Rating	Unit
Supply Voltage	V _{CC}	6	V
Supply Current	I _{CC}	15	mA
Power Dissipation	P _D	90	mW
Storage Temperature	T _{opr}	-20~+75	°C
Temperature	T _{stg}	-55~+125	°C

■ Electrical Characteristics(V_{CC}=5V, Ta=25°C)

Item	Symbol	Test Circuit	Condition	min.	typ.	max.	Unit
Supply Current	I _{tot}	1	Circuit Current with No Signal		5	7	mA
Encode Holding Voltage-1	V _{SE}		Encode Pin⑩ Applied Voltage	3.5			V
Decode Holding Voltage-2	V _{SD}		Decode Pin⑩ Applied Voltage			1.5	V
Encode Output Voltage-1	V _{OE1}	2	Encode (REF) V _{in} =400Hz, -15dBV	-16	-15	-14	dBV
Encode Output Voltage-2	V _{OE2}	2	Encode V _{in} =400Hz, -35dBV	-26	-25	-24	dBV
Encode Output Voltage-3	V _{OE3}	2	Encode V _{in} =400Hz, -55dBV	-36.5	-35	-33.5	dBV
Decode Output Voltage-1	V _{OD1}	2	Decode (REF) V _{in} =400Hz, -15dBV	-17	-15	-13	dBV
Decode Output Voltage-2	V _{OD2}	2	Decode V _{in} =400Hz, -35dBV	-57	-55	-53	dBV
Decode Output Voltage-3	V _{OD3}	2	Decode V _{in} =400Hz, -50dBV	-88	-85	-82	dBV
Maximum Output Voltage-1	V _{OM1}	2	Encode f=400Hz, THD=3%	-8.5	-6.5		dBV
Maximum Output Voltage-2	V _{OM2}	2	Decode f=400Hz, THD=3%	0	2		dBV
Distortion-1	THD ₁	2	Encode V _{in} =400Hz, -15dBV		0.2	0.4	%
Distortion-2	THD ₂	2	Decode V _{in} =400Hz, -15dBV		0.2	0.4	%
Noise Output Voltage-1	V _{NO1}	3	Encode f=20Hz~20kHz, R _g =0		-60	-55	dBV
Noise Output Voltage-2	V _{NO2}	3	Decode f=20Hz~20kHz, R _g =0		-100	-90	dBV
Crosstalk-1	CT ₁	4	Encode V _{in} =1kHz, -15dBV			-40	dBV
Crosstalk-2	CT ₂	4	Decode V _{in} =1kHz, -15dBV			-70	dBV
Operating Supply Voltage	V _{OPR} *		Supply Voltage at Which Actual Operation is Made Possible	4.5	5	5.5	V
Input Impedance (Pin⑩)	Z _{inE} *		Encode Input f=1kHz		10		kΩ
Input Impedance (Pin⑬)	Z _{inD} *		Decode Input f=1kHz		10		kΩ
Output Impedance (Pin⑧)	Z _{OUT} *		f=1kHz			100	Ω
Frequency Characteristic-1	V _{fE1} *		Encode V _{in} =4kHz, -15dBV	-13.3	-12.3	-11.3	dBV
Frequency Characteristic-2	V _{fE2} *		Encode V _{in} =7kHz, -15dBV	-11.9	-10.9	-9.9	dBV
Frequency Characteristic-3	V _{fE3} *		Encode V _{in} =14kHz, -15dBV	-11.2	-9.7	-8.2	dBV

*There are reference values for designing and not guaranteed values.

Test Circuit 1 (I_{tot})

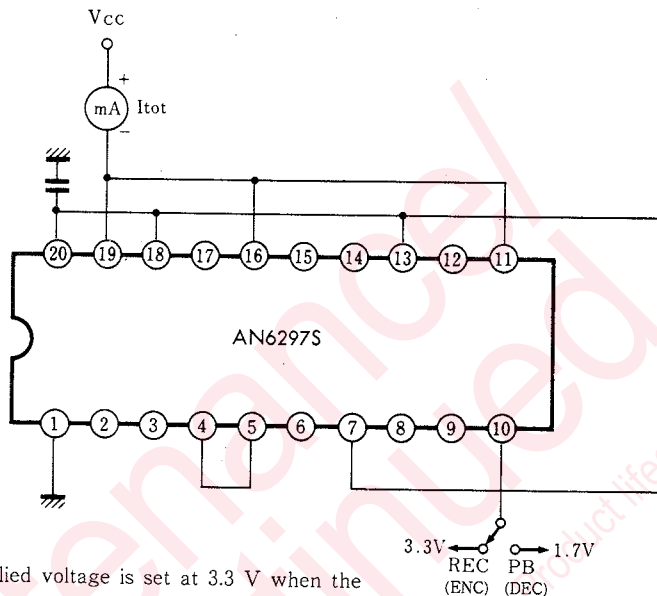

*1 The Pin ⑩ applied voltage is set at 3.3 V when the encode is performed and 1.7 V when the decode is performed.

Test Circuit 2 (V_{SE} , V_{SD} , V_{OE1} , V_{OE2} , V_{OE3} , V_{OD1} , V_{OD2} , V_{OD3} , V_{OM1} , V_{OM2} , THD_1 , THD_2)

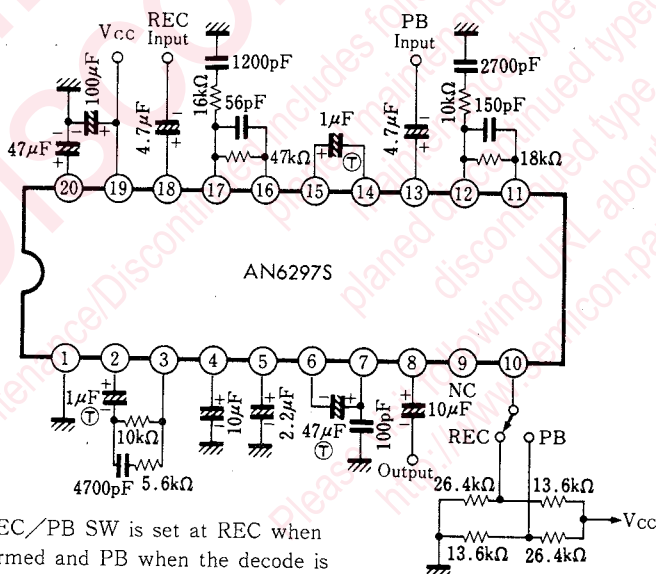

*1 The Pin ⑩ REC/PB SW is set at REC when the encode is performed and PB when the decode is performed.

*2 The input signal is input to Pin ⑱ (REC Input) when the encode is performed and Pin ⑬ (PB Input) when the decode is performed.

*3 The output is Pin ⑧ (Output).

*4 The percentage of errors of the capacitance of 1 µF or less and all the resistances must be within 1 %.

Test Circuit 3 (V_{NO1} , V_{NO2})

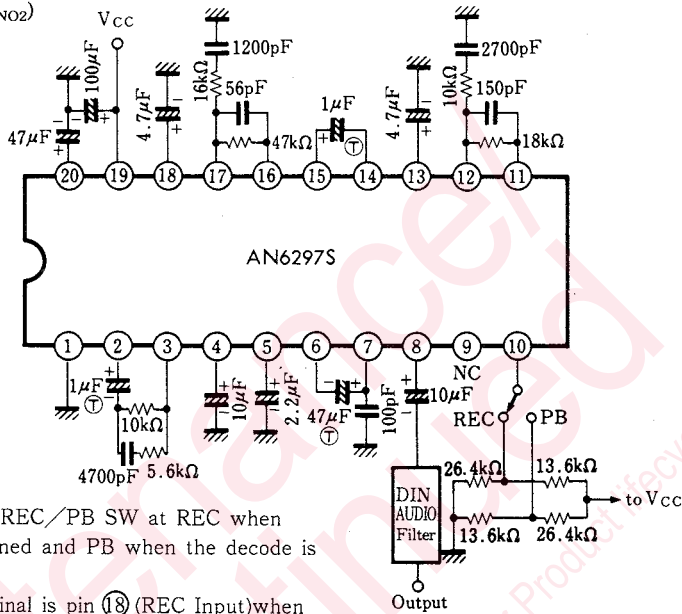

- *1 Set the Pin ⑩ REC/PB SW at REC when the encode is performed and PB when the decode is performed.
- *2 The input terminal is pin ⑱ (REC Input) when the encode is performed and Pin ⑬ (PB Input) when the decode is performed.
- *3 The output is Pin ⑧ (Output).
- *4 The output must pass through the DIN AUDIO filter.
- *5 The percentage of errors of the capacitance of 1 μ F or less and all the resistances must be within 1 %.

Test Circuit 4 (CT_1 , CT_2)

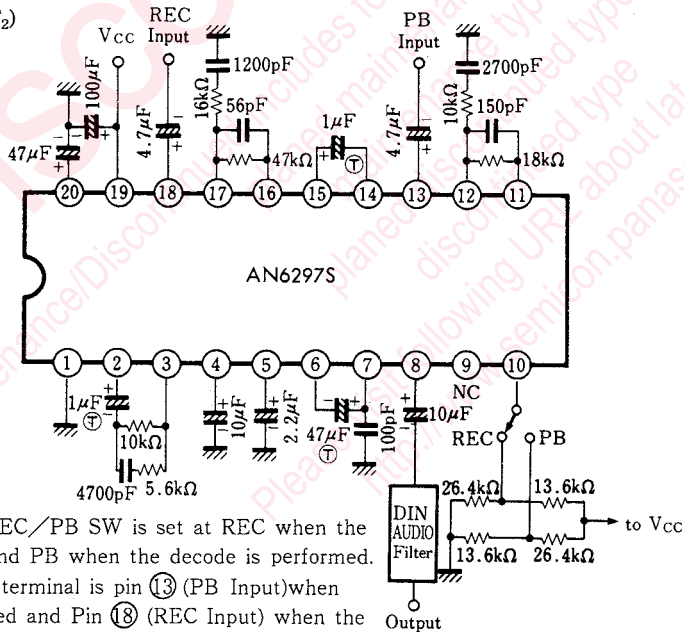

- *1 Set the Pin ⑩ REC/PB SW is set at REC when the encode is performed and PB when the decode is performed.
- *2 The signal input terminal is pin ⑬ (PB Input) when the encode is performed and Pin ⑱ (REC Input) when the decode is performed.
- *3 The output is Pin ⑧ (Output).
- *4 The output must pass through the DIN AUDIO filter.
- *5 The percentage of errors of the capacitance of 1 μ f or less and all the resistances must be within 1 %.

■ Pin

Pin No.	Pin Name	Pin No.	Pin Name
1	GND	11	Amp. 2 Output
2	BF Amp. 2 Output	12	Amp. 2 Feedback/BF Amp. 1 Input
3	L.S. Input	13	Decode Input
4	Hold Recovery	14	CCA G.C. Input
5	Recovery	15	BF Amp. 1 Output
6	ACC G.C. Output	16	Amp. 1 Output
7	CCA Amp. Input	17	Amp. 1 Feedback/Output Amp. Input
8	Signal Output	18	Encode Input
9	Output Amp. Feedback	19	V _{cc}
10	Encode/Decode SW	20	Reference Voltage

■ Application Circuits

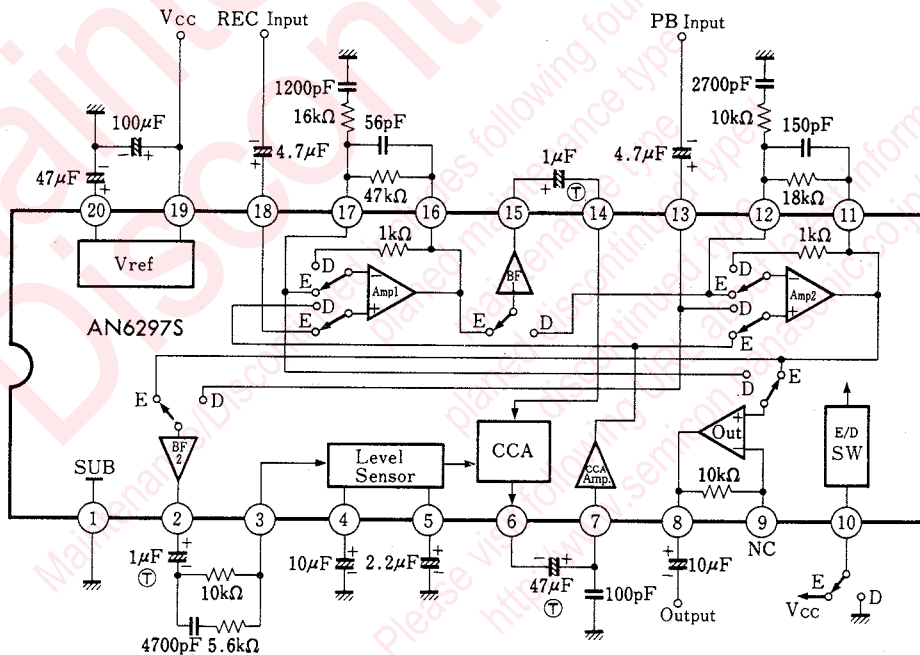

Note) It is possible to correct the output amplifier gain and the f characteristic by connecting a suitable resistance and a capacitor between Pin ⑨ and GND.

Request for your special attention and precautions in using the technical information and semiconductors described in this book

- (1) If any of the products or technical information described in this book is to be exported or provided to non-residents, the laws and regulations of the exporting country, especially, those with regard to security export control, must be observed.
- (2) The technical information described in this book is intended only to show the main characteristics and application circuit examples of the products. No license is granted in and to any intellectual property right or other right owned by Panasonic Corporation or any other company. Therefore, no responsibility is assumed by our company as to the infringement upon any such right owned by any other company which may arise as a result of the use of technical information described in this book.
- (3) The products described in this book are intended to be used for standard applications or general electronic equipment (such as office equipment, communications equipment, measuring instruments and household appliances).
Consult our sales staff in advance for information on the following applications:
 - Special applications (such as for airplanes, aerospace, automobiles, traffic control equipment, combustion equipment, life support systems and safety devices) in which exceptional quality and reliability are required, or if the failure or malfunction of the products may directly jeopardize life or harm the human body.
 - Any applications other than the standard applications intended.
- (4) The products and product specifications described in this book are subject to change without notice for modification and/or improvement. At the final stage of your design, purchasing, or use of the products, therefore, ask for the most up-to-date Product Standards in advance to make sure that the latest specifications satisfy your requirements.
- (5) When designing your equipment, comply with the range of absolute maximum rating and the guaranteed operating conditions (operating power supply voltage and operating environment etc.). Especially, please be careful not to exceed the range of absolute maximum rating on the transient state, such as power-on, power-off and mode-switching. Otherwise, we will not be liable for any defect which may arise later in your equipment.
 - Even when the products are used within the guaranteed values, take into the consideration of incidence of break down and failure mode, possible to occur to semiconductor products. Measures on the systems such as redundant design, arresting the spread of fire or preventing glitch are recommended in order to prevent physical injury, fire, social damages, for example, by using the products.
- (6) Comply with the instructions for use in order to prevent breakdown and characteristics change due to external factors (ESD, EOS, thermal stress and mechanical stress) at the time of handling, mounting or at customer's process. When using products for which damp-proof packing is required, satisfy the conditions, such as shelf life and the elapsed time since first opening the packages.
- (7) This book may be not reprinted or reproduced whether wholly or partially, without the prior written permission of our company.



LittleDiode supplies new, hard to find or obsolete electronic components and semiconductors all over the world.

With over two million different components listed you are sure to find the part you need.

Feel free to visit us today at our online store:

LittleDiode.com

Looking forward to providing you with the best possible service.