

AN7082K/S

Pre/Power Amplifier, Governor Single Chip IC for 3V Headphone Stereo

■ Description

The AN7082K/S are the monolithic integrated circuits most suitable for stereo headphone cassette player with integrated pre-amp., power amp., motor governor into a single chip and built-in electronic VR.

■ Features

- Wide operating supply voltage range:
 $V_{cc(opr)} = 1.8V \sim 6V$
- Fewer peripheral parts
- Both channel VR control by single string VR is possible due to electronic VR built-in
- Available for graphic equalizer

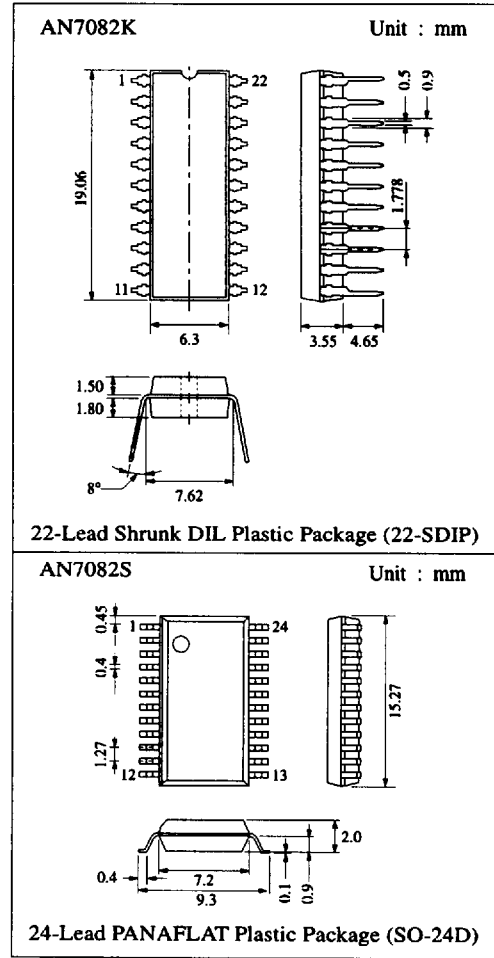

■ Block Diagram

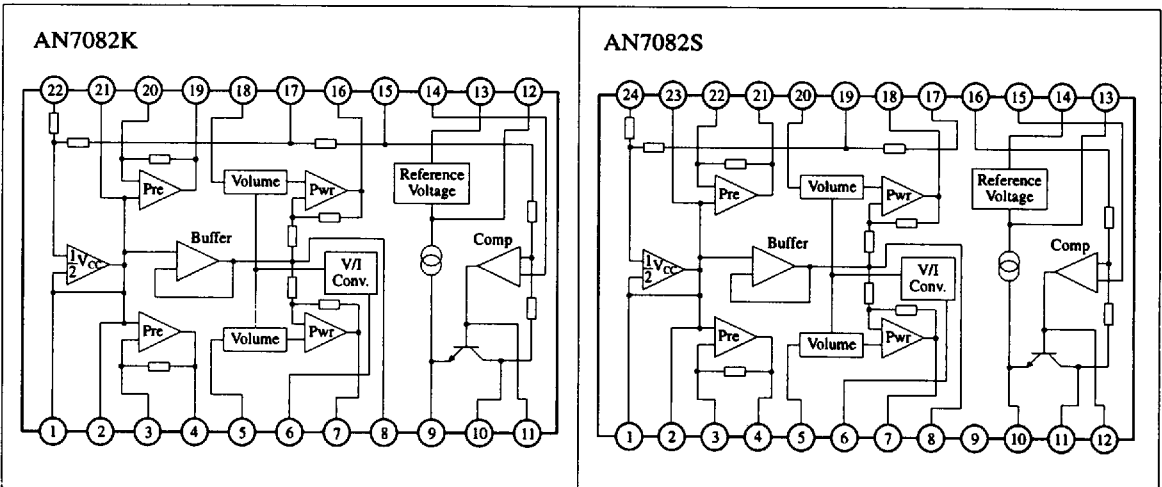

■ Absolute Maximum Ratings (Ta=25°C)

Item	Symbol	Rating	Unit
Supply Voltage	V _{CC}	7	V
Supply Current	I _{CC}	1000	mA
Power Dissipation	P _D	1000	mW
Operating Ambient Temperature	Topr	-25 ~ +75	°C
Storage Temperature	Tstg	-55 ~ +150	°C

Operating Supply Voltage Range: V_{CC} = 1.8V ~ 6.0V

■ Electrical Characteristics (Ta=25°C, V_{CC}=3V, f=1kHz, R_L=32Ω, Volume Max.)

Item	Symbol	Condition	min.	typ.	max.	Unit
Quiescent Current	I _{CQ}	V _{in} = 0V, I _m = 0mA	10	20	35	mA

Pre Amplifier

Close Loop Gain	G _{VC}	V _O = 0.3V	34	37.5	40	dB
Maximum Output Voltage	V _{O(max)}	THD = 1%	0.6	0.8		V
Total Harmonic Distortion	THD	V _O = 300mV		0.05	0.5	%
Input Noise Voltage	V _{ni}	V _{in} = 0V, R _g = 2.2kΩ, BPF (300Hz ~ 20kHz)		1.8	5.0	μV
Channel Balance	CB	V _{in} = 5mV	-2	0	+2	dB

Attenuator

Maximum Attenuation	V _{a(max)}	V _O = 0.4V, Pin 6 = 0	60	65		dB
---------------------	---------------------	----------------------------------	----	----	--	----

Power Amplifier

Voltage Gain	G _V	P _{out} = 5mW	25.5	28	30.5	dB
Maximum Power	P _O	THD = 10%, R _L = 32Ω	15	20		mW
Total Harmonic Distortion	THD	P _{out} = 5mW		0.2	1.0	%
Channel Balance	CB	V _O = 0.4V	-2	0	+2	dB
Output Noise Voltage	V _{no}	BPF (300Hz ~ 20kHz)		0.3	0.4	mV
Ripple Rejection	RR	f = 100Hz, 50mV	34	40		dB
Crosstalk	CT	V _O = 0.6V	25	35		dB

Motor Governor

Load Regulation 1	$\frac{\Delta V_a}{V_a} / \Delta I_a$	I ₁₀ = 30mA ~ 200mA		0.01	0.1	%/mA
Line Regulation 1	$\frac{\Delta V_a}{V_a} / \Delta V_{CC}$	I _m = 50mA, V _{CC} = 1.8 ~ 6.0V		0.1	1.0	%/V
Reference Voltage	V _{REF}	I _m = 100mA, R ₁₃₋₁₂ > 10kΩ		1.28		V
Saturation Voltage	V _{sat}	I _m = 100mA, 1.8V, R _a = 4.7Ω		0.2		V
Line Regulation 2	$\frac{\Delta V_{REF}}{V_{REF}} / \Delta V_{CC}$	I _m = 50mA, V _{CC} = 1.8 ~ 6.0V		0.2		%/V
Temperature Characteristics	$\frac{\Delta V_a}{V_a} / \Delta T_a$	T _a = -25°C ~ +75°C		0.01		%/°C

■ Pin

Pin No.	Pin Name	Pin No.	Pin Name
1(1)	Pre-V _{REF}	13 (12)	Motor Ref. Voltage (-)
2(2)	Channel 1 Pre Amp. Input	14 (13)	Motor Ref. Voltage (+)
3(3)	Channel 1 Pre Negative Feedback	15 (14)	Comparator Input
4(4)	Channel 1 Pre Amp. Output	16	Motor V _{CC}
5(5)	Channel 1 Volume Input	17 (15)	Power V _{CC}
6(6)	Volume Control	18 (16)	Channel 2 Power Amp. Output
7(7)	Channel 1 Power Amp. Output	19 (17)	Ripple Filter
8(8)	Buffer Output	20 (18)	Channel 2 Volume Input
9(9)	Power GND	21 (19)	Channel 2 Pre Amp. Output
10	Motor GND	22 (20)	Channel 2 Pre Negative Feedback
11 (10)	Motor Terminal (-)	23 (21)	Channel 2 Pre Amp. Input
12 (11)	Phase Compensation	24 (22)	Pre GND

Note: The pin numbers in the parenthesis are for AN7082K

■ Application Circuit

(AN7082K)

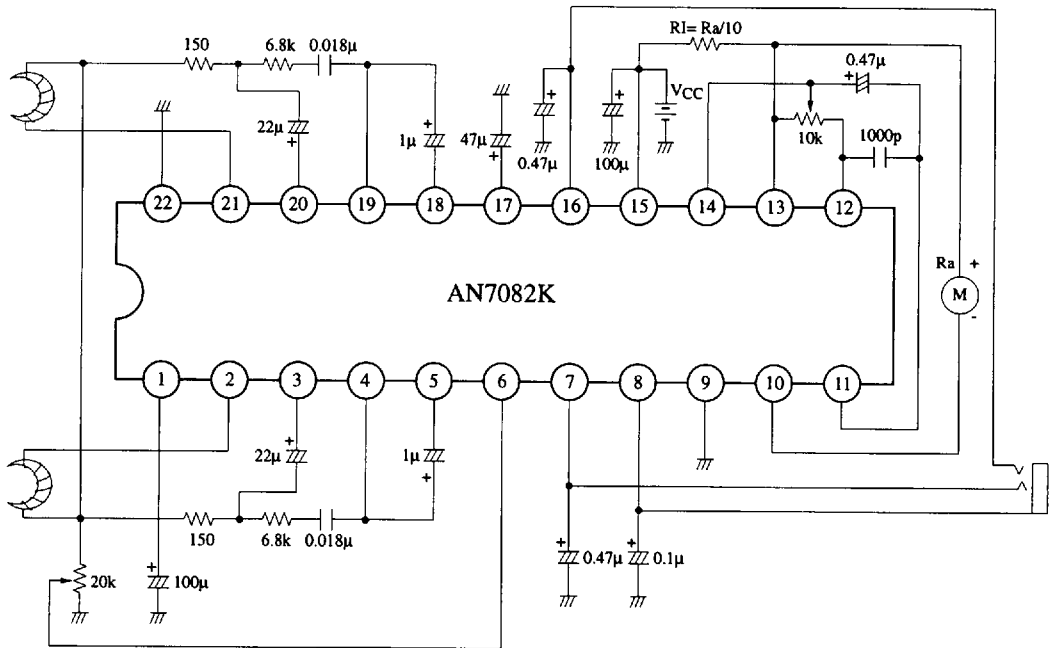

■ Application Circuit (Continue)
(AN7082S)

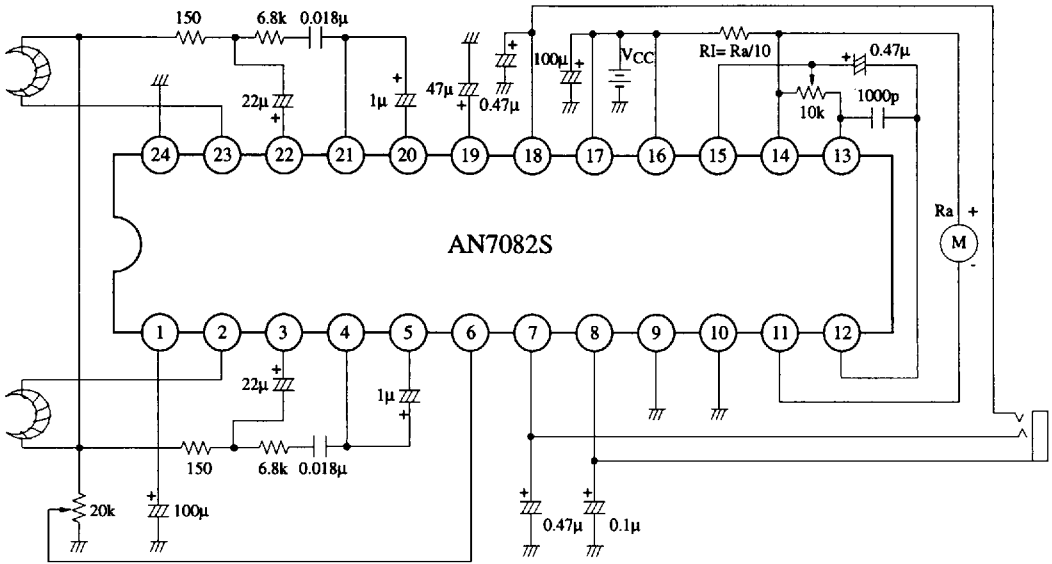

■ AN7082K Radio Application Circuit

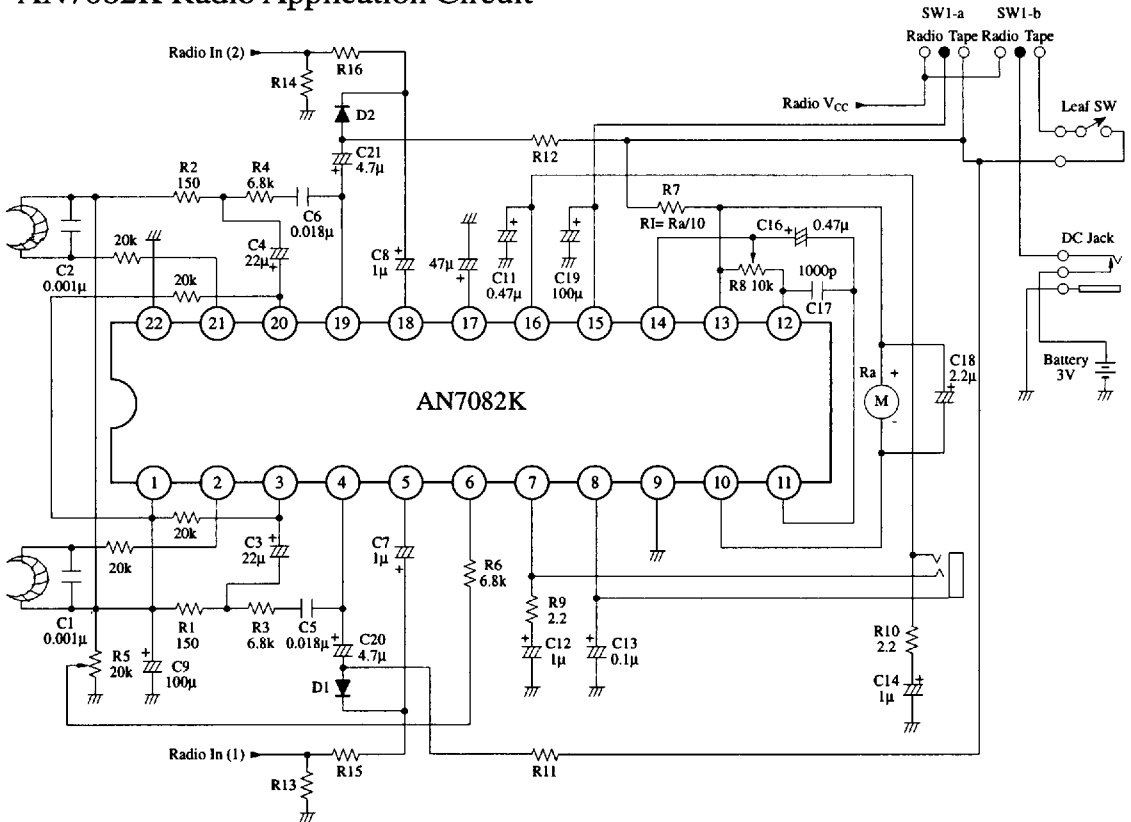

Note: Resistors R11/R12 and diodes D1/D2 are used to mute pre-amp during radio mode.
Resistor R13/R14 act as multiplexer load.
Resistors R15/R16 are used to achieve same output level during radio/playback mode.

■ Application Notes

1. Tuner Connection

- AN7082K can be combined with any tuner IC to form 2-chip Headphone stereo player. This is possible by adding 2 resistors, R11/R12 & 2 diodes, D1/D2 to function as Pre-amp Mute circuit during Radio operation.
- During Tape playback mode R11/R12 & D1/D2 are being DC biased through Tape V_{CC}, such that the Tape signal from Pre-amp output can pass through & be amplified by the subsequent power stage.
- During Radio Mode, V_{CC} supply to R11/R12 & D1/D2 is cut off, causing D1/D2 to be inoperative. As such, any Pre-amp output signals from tape will be blocked by the diodes and will not contribute to radio noise.
- Values of R11/R12 are selected to be equal to that of Tuner MPX load. Values of R13/R14 are adjusted to achieve same output power level during tape playback & radio modes.

2. Motor Hum Noise

- To reduce output noise, add C7/C8 1000p between Pre NF pins & Pre-Out pins on both channels respectively.
- Where practical, the distance between Motor and AN7082K on PCB should be kept as far as possible, especially the orientation of Pre-amp input pins. This is to reduce Motor Hum Noise feedback through to AN7082K/S inputs.

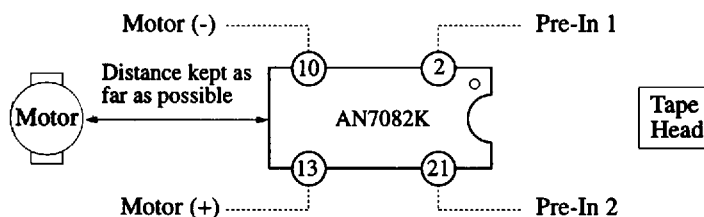

- The PCB layout tracks from pin 10 and pin 13 to Motor(-) and Motor(+) terminals should also be maintained as far as possible from Pre-amp inputs pins to reduce motor interference.
- The motor assembly is preferably covered by some metal shield to reduce noise radiation of the unit.



LittleDiode supplies new, hard to find or obsolete electronic components and semiconductors all over the world.

With over two million different components listed you are sure to find the part you need.

Feel free to visit us today at our online store:

LittleDiode.com

Looking forward to providing you with the best possible service.