

GaAs FET

CFY 25

- Low noise
- High gain
- For front-end amplifiers
- Ion-implanted planar structure
- All gold metallization

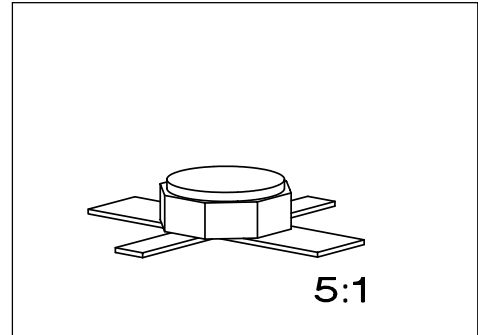

ESD: Electrostatic discharge sensitive device, observe handling precautions!

Type	Marking	Ordering Code (tape and reel)	Pin Configuration				Package ¹⁾
			1	2	3	4	
CFY 25-17	C 5	Q62703-F106	D	S	G	S	Micro-X
CFY 25-20	C 6	Q62703-F107					
CFY 25-23	C 7	Q62703-F108					

Maximum Ratings

Parameter	Symbol	Values	Unit
Drain-source voltage	V_{DS}	5	V
Drain-gate voltage	V_{DG}	7	
Gate-source voltage	V_{GS}	- 5 ... + 0	
Drain current	I_D	80	mA
Total power dissipation, $T_S \leq 56 \text{ }^\circ\text{C}^2)$	P_{tot}	250	mW
Channel temperature	T_{ch}	150	$^\circ\text{C}$
Storage temperature range	T_{stg}	- 65 ... + 150	

Thermal Resistance

Channel - soldering point ²⁾	$R_{th\ chS}$	375	K/W
---	---------------	-----	-----

¹⁾ For detailed information see chapter Package Outlines.

²⁾ T_S is measured on the source lead at the soldering point to the pcb.

Electrical Characteristics

at $T_A = 25\text{ }^\circ\text{C}$, unless otherwise specified.

Parameter	Symbol	Values			Unit
		min.	typ.	max.	
Drain-source saturation current $V_{DS} = 3\text{ V}, V_{GS} = 0$	I_{DSS}	15	30	60	mA
Pinch-off voltage $I_D = 1\text{ mA}, V_{DS} = 3\text{ V}$	V_p	- 0.3	- 1.0	- 3.0	V
Gate leakage current $I_D = 15\text{ mA}, V_{DS} = 3\text{ V}$	I_G	-	0.1	2	μA
Transconductance $I_D = 15\text{ mA}, V_{DS} = 3\text{ V}$	g_m	30	40	-	mS
Noise figure $I_{DS} = 15\text{ mA}, V_{DS} = 3\text{ V}, f = 12\text{ GHz}$	F				dB
CFY 25-17	-	1.6	1.7		
CFY 25-20	-	1.9	2.0		
CFY 25-23	-	2.2	2.3		
Associated gain $I_{DS} = 15\text{ mA}, V_{DS} = 3\text{ V}, f = 12\text{ GHz}$	G_a				
CFY 25-17	9	9.5	-		
CFY 25-20	8.5	9	-		
CFY 25-23	8.5	9	-		

Total power dissipation $P_{tot} = f(T_S; T_A^*)$
 * Package mounted on alumina

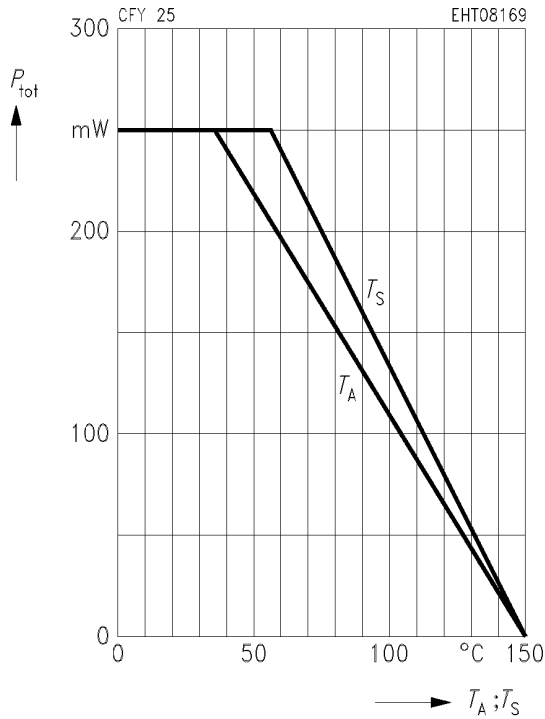

Output characteristics $I_D = f(V_{DS})$

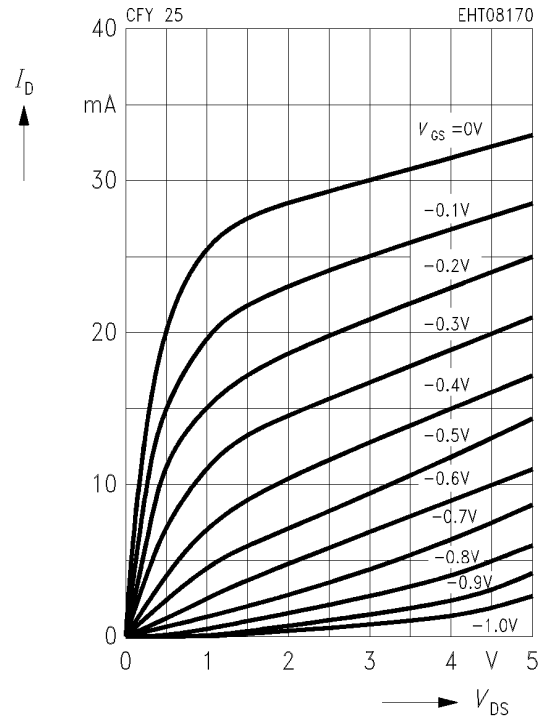

Transfer characteristics $I_D = f(V_G)$
 $V_{DS} = 3 V$

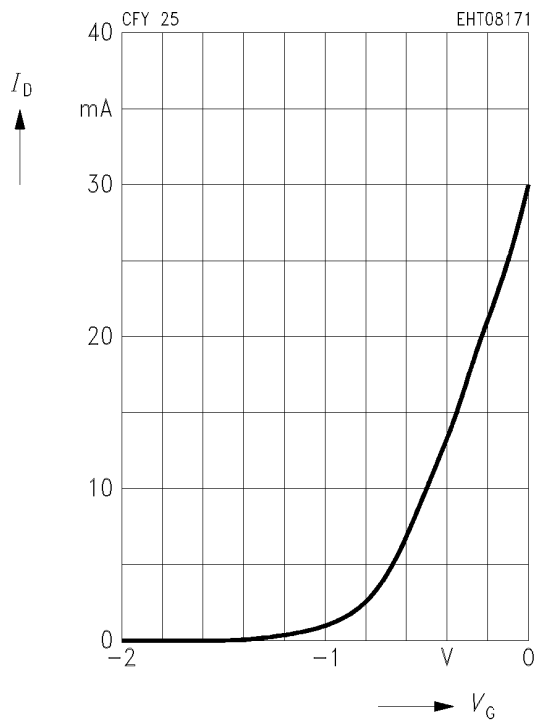

Common Source Noise Parameters

f	F_{min}	G_a	Γ_{opt}		R_N	r_N	N	$F_{50\ \Omega}$	$G(F_{50\ \Omega})$
GHz	dB	dB	MAG	ANG	Ω	—	—	dB	dB

$I_D = 15\text{ mA}$, $V_{DS} = 3.0\text{ V}$, $Z_0 = 50\ \Omega$

2	0.60	18.5	0.70	31	29	0.580	0.10	2.0	11.4
4	0.77	14.6	0.59	63	21	0.420	0.14	1.8	10.5
6	1.00	12.4	0.50	103	13	0.260	0.19	1.8	9.3
8	1.25	11.0	0.47	140	7.3	0.146	0.23	2.0	8.2
10	1.55	9.8	0.45	174	5.6	0.112	0.28	2.4	7.3
12	1.77	9.0	0.43	-156	7.1	0.142	0.29	2.5	6.4
14	2.15	8.1	0.41	-130	18	0.360	0.46	3.0	5.8

Source impedance for min. noise figure

$I_D = 15\text{ mA}$, $V_{DS} = 3\text{ V}$

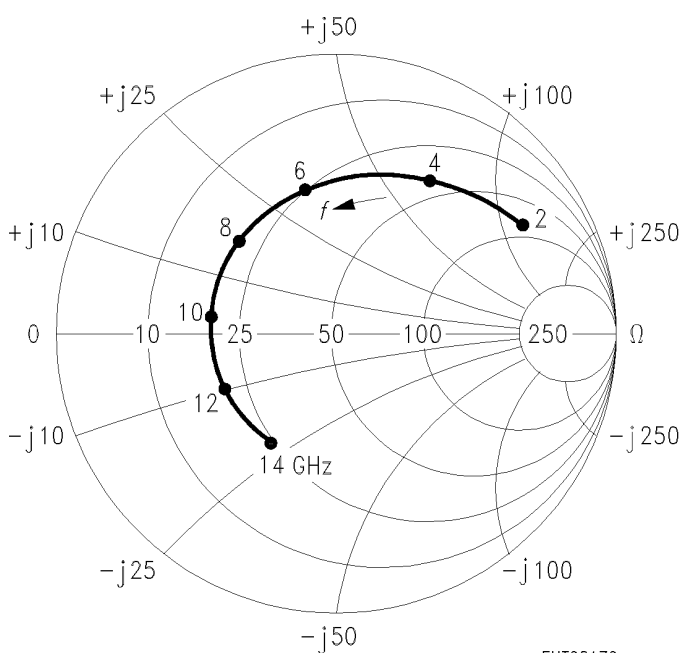

EHT08172

Circles of constant noise figure

$I_D = 15\text{ mA}$, $V_{DS} = 3\text{ V}$, $f = 12\text{ GHz}$

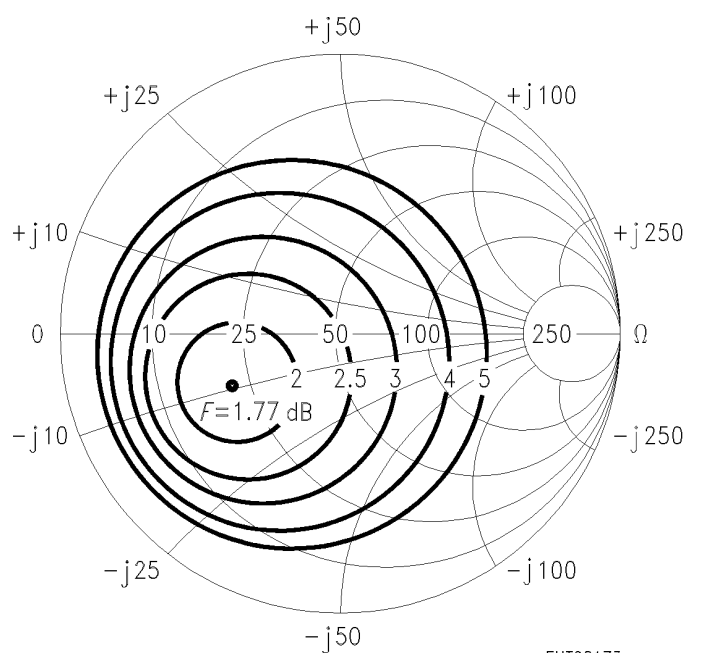

EHT08173

Minimum noise figure $F_{min} = f(f)$
Associated gain $G_a = f(f)$
 $I_D = 15 \text{ mA}$, $V_{DS} = 3 \text{ V}$, Z_{Sopt}

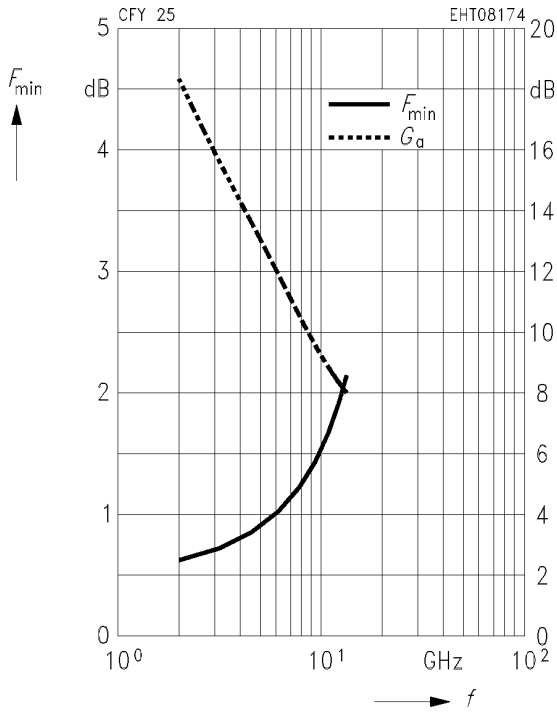

Minimum noise figure $F_{min} = f(I_D)$
Associated gain $G_a = f(I_D)$
 $V_{DS} = 3 \text{ V}$, $f = 12 \text{ GHz}$, Z_{Sopt}

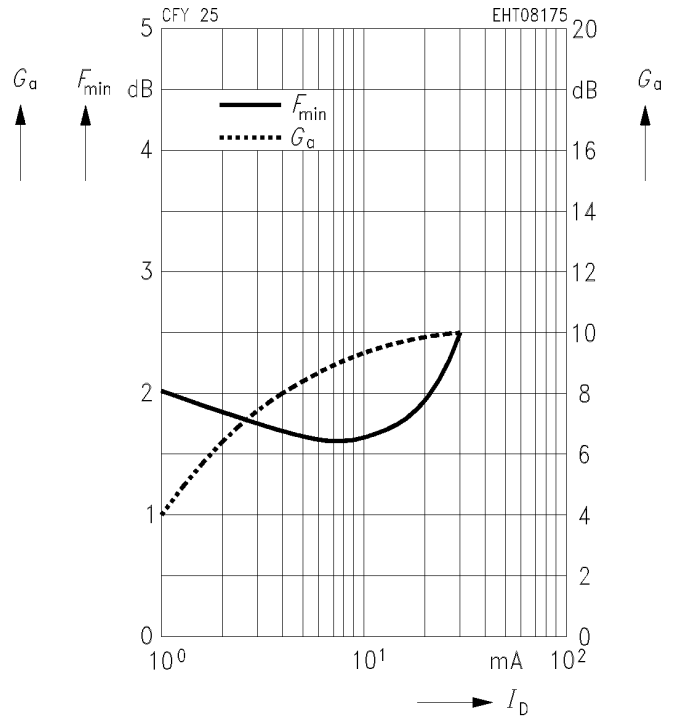

Common Source S Parameters

<i>f</i>	<i>S</i> ₁₁		<i>S</i> ₂₁		<i>S</i> ₁₂		<i>S</i> ₂₂	
GHz	MAG	ANG	MAG	ANG	MAG	ANG	MAG	ANG
<i>I_D</i> = 15 mA, <i>V_{DS}</i> = 3 V, <i>Z₀</i> = 50 Ω								
1.0	0.99	- 21	3.83	161	0.026	75	0.68	- 13
2.0	0.96	- 42	3.73	141	0.049	61	0.66	- 27
3.0	0.91	- 67	3.55	121	0.069	45	0.63	- 41
4.0	0.86	- 87	3.34	103	0.083	33	0.59	- 55
5.0	0.81	- 107	3.10	86	0.093	21	0.56	- 66
6.0	0.77	- 125	2.92	70	0.100	11	0.52	- 77
7.0	0.74	- 145	2.74	54	0.105	1	0.48	- 89
8.0	0.70	- 165	2.57	37	0.107	- 9	0.45	- 102
9.0	0.68	178	2.42	23	0.108	- 17	0.42	- 112
10.0	0.67	161	2.31	9	0.109	- 24	0.41	- 124
11.0	0.67	146	2.20	- 4	0.110	- 30	0.39	- 134
12.0	0.66	132	2.10	- 17	0.110	- 36	0.37	- 145
13.0	0.66	117	2.02	- 31	0.110	- 42	0.36	- 158
14.0	0.66	103	1.94	- 44	0.112	- 49	0.35	- 169
15.0	0.66	90	1.90	- 57	0.115	- 55	0.34	180
16.0	0.66	77	1.84	- 70	0.119	- 63	0.33	165
17.0	0.66	63	1.80	- 84	0.125	- 72	0.32	151
18.0	0.66	47	1.78	- 99	0.132	- 83	0.31	136

*S*₁₁, *S*₂₂

I_D = 15 mA, *V_{DS}* = 3 V, *Z₀* = 50 Ω

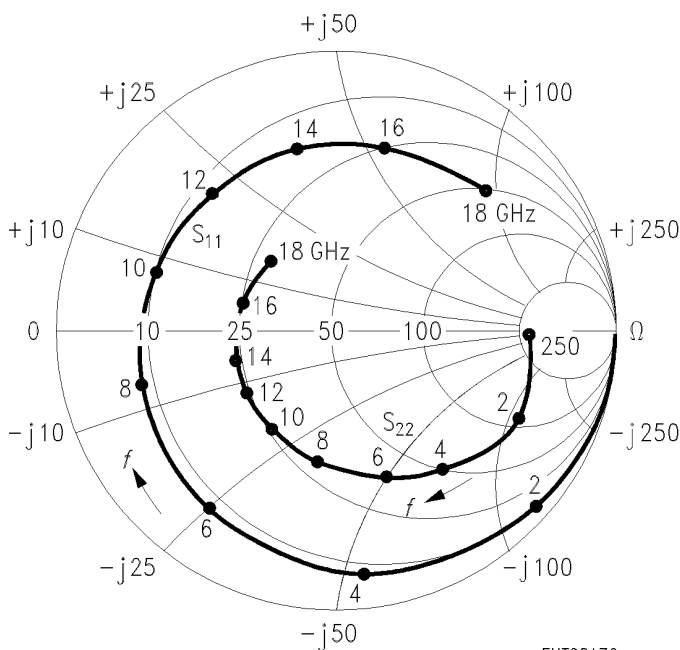

EHT08176

*S*₁₂, *S*₂₁

I_D = 15 mA, *V_{DS}* = 3 V, *Z₀* = 50 Ω

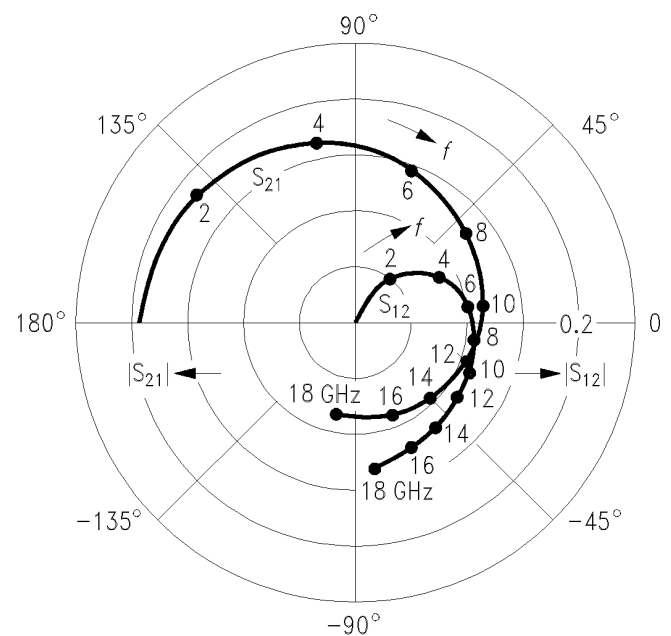

EHT08177



LittleDiode supplies new, hard to find or obsolete electronic components and semiconductors all over the world.

With over two million different components listed you are sure to find the part you need.

Feel free to visit us today at our online store:

LittleDiode.com

Looking forward to providing you with the best possible service.