

AN7190NK, AN7190NZ

Dual 20 W BTL power amplifier

■ Overview

The AN7190NK and the AN7190NZ are audio power ICs developed for the sound output of car audio (dual 20 W). It is incorporating various protective circuits to protect the IC from destruction by GND-open, short circuit to GND and power supply surge which are the important subject of power IC protection, so the IC will largely contribute to a high reliability design of equipment. Also, it is incorporating a perfect muting circuit which is free from shock noise, so that a shock noise design under the set transient condition can be made easily using together with its standby function.

■ Features

- BTL 20 W \times 2-channel (4 Ω), $G_V = 40$ dB
- Built-in various protection circuits (thermal protection, short circuit to V_{CC} and short circuit to GND, V_{CC} -open short circuit to V_{CC} , GND-open short circuit to GND, overvoltage and supply surge, and ASO, etc.) Especially, the supply surge breakdown voltage is 100 V or more.
GND open breakdown voltage is 16 V or more.
- Built-in standby function
Free from shock noise at STB on/off.
- Built-in muting function
Free from shock noise at mute-on/off.
Adapting attenuator method so that abnormal sound due to waveform deformation is not generated.
Attack time, recovery time are 50 ms or less.
- Reduction in external components
It eliminates the need for NF and BS electrolytic capacitors.
Muting function is not required, and power supply choke coil is unnecessary.
- Provided with beep sound input pin
- 2 Ω load guaranteed

■ Applications

- Car audio

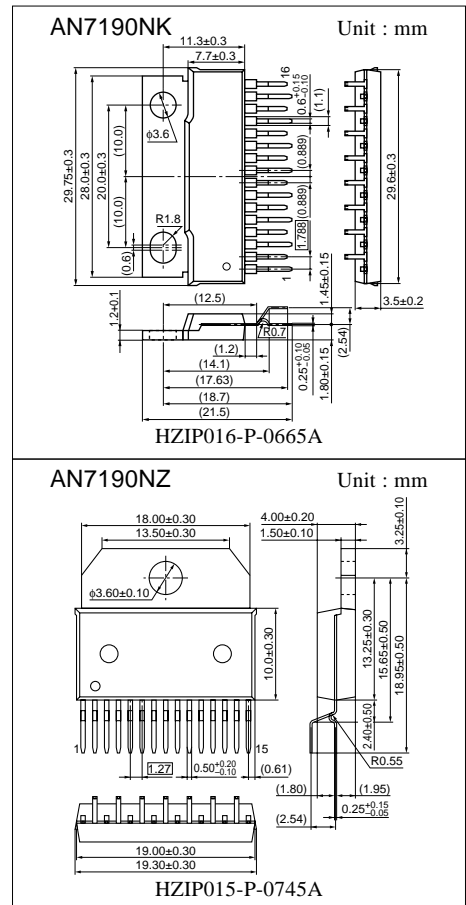

■ Block Diagram

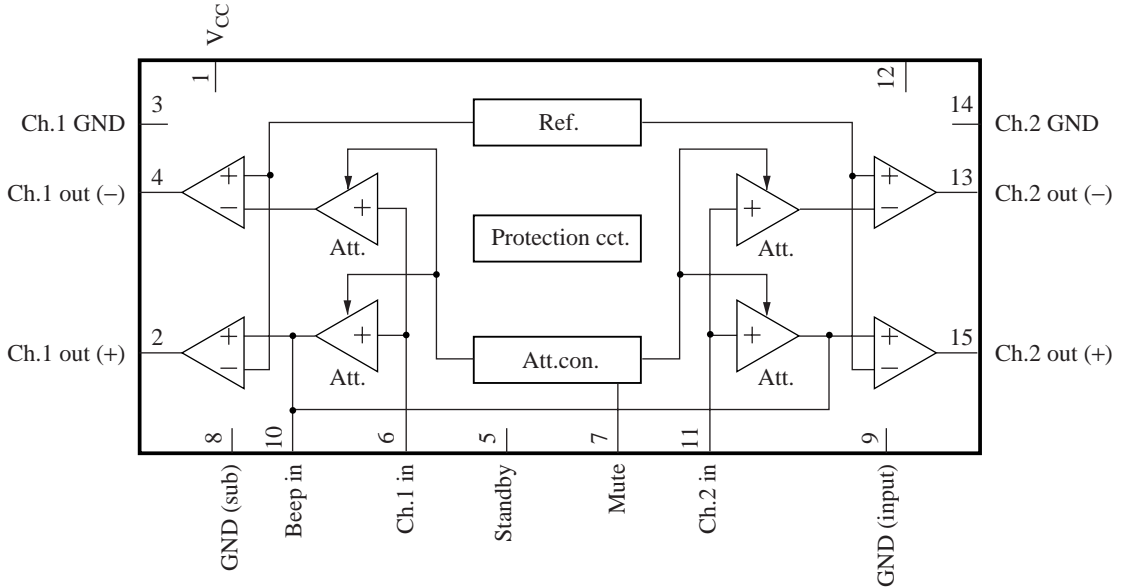

■ Pin Descriptions

Pin No.	Description	Pin No.	Description
1	Power supply	9	Grounding (input)
2	Ch.1 output (+)	10	Beep sound input
3	Grounding (output ch.1)	11	Ch.2 input
4	Ch.1 output (-)	12	Ripple filter
5	Standby	13	Ch.2 output (-)
6	Ch.1 input	14	Grounding (output ch.2)
7	Muting	15	Ch.2 output (+)
8	Grounding (sub)		

■ Absolute Maximum Ratings

Parameter	Symbol	Rating	Unit	
Supply voltage *2	V_{CC}	25	V	
Peak supply voltage *3	V_{surge}	80	V	
Supply current	I_{CC}	9.0	A	
Power dissipation *4	P_D	AN7190NK	32.5	W
		AN7190NZ	59	
Operating ambient temperature *1	T_{opr}	- 30 to + 85	°C	
Storage temperature *1	T_{stg}	- 55 to + 150	°C	

Note) *1 : $T_a = 25^\circ\text{C}$ except operating ambient temperature and storage temperature.

- *2 : Without signal
- *3 : Time = 0.2 s
- *4 : $T_a = 85^\circ\text{C}$

■ Recommended Operating Range

Parameter	Symbol	Range	Unit
Supply voltage	V_{CC}	8.0 to 18.0	V

■ Electrical Characteristics at $V_{CC} = 13.2$ V, freq. = 1 kHz, $T_a = 25^\circ\text{C}$

Parameter	Symbol	Conditions	Min	Typ	Max	Unit
Quiescent current	I_{CQ}	$V_{IN} = 0$ mV, $R_L = 4 \Omega$	—	120	250	mA
Standby current	I_{STB}	$V_{IN} = 0$ mV, $R_L = 4 \Omega$	—	1	10	μA
Output noise voltage *1	V_{NO}	$R_g = 4.7$ k Ω , $R_L = 4 \Omega$	—	0.22	0.5	mV[rms]
Voltage gain 1	G_{V1}	$V_{IN} = 20$ mV, $R_L = 4 \Omega$	38	40	42	dB
Total harmonic distortion 1	THD_1	$V_{IN} = 20$ mV, $R_L = 4 \Omega$	—	0.07	0.4	%
Maximum output power 1	P_{O1}	$THD = 10\%$, $R_L = 4 \Omega$	16	18	—	W
Ripple rejection ratio *1	RR	$R_L = 4 \Omega$, $R_g = 4.7$ k Ω , $V_r = 1$ V[rms], $f_r = 1$ kHz	60	72	—	dB
Channel balance	CB	$V_{IN} = 20$ mV, $R_L = 4 \Omega$	—	0	1	dB
Cross-talk *1	CT	$V_{IN} = 20$ mV, $R_L = 4 \Omega$, $R_g = 4.7$ k Ω	55	65	—	dB
Output offset voltage	V_{OFF}	$R_g = 4.7$ k Ω , $R_L = 4 \Omega$	-350	0	350	mV
Muting effect *1	MT	$V_{IN} = 20$ mV, $R_L = 4 \Omega$	70	82	—	dB
Input impedance	Z_I	$V_{IN} = \pm 0.3$ V _{DC}	22	28	35	k Ω
Voltage gain 2	G_{V2}	$V_{IN} = 20$ mV, $R_L = 2 \Omega$	38	40	42	dB
Total harmonic distortion 2	THD_2	$V_{IN} = 20$ mV, $R_L = 2 \Omega$	—	0.1	0.5	%
Maximum output power 2	P_{O2}	$THD = 10\%$, $R_L = 2 \Omega$	16	24	—	W
Shock noise *2	V_S	$R_L = 4 \Omega$, $R_g = 4.7$ k Ω , $V_{MUTE} = 5$ V, $V_{STB} = \text{on/off}$, 50 Hz HPF on	-100	0	100	mV[p-0]
Total harmonics distortion 3	THD_3	$V_{IN} = 5$ mV, $f_{IN} = 20$ kHz $R_g = 4.7$ k Ω , $R_L = \infty$	—	0.10	0.5	%

Note) *1 : Measurement using a bandwidth 15 Hz to 30 kHz (12 dB/OCT) filter.

*2 : For $V_{STB} = \text{on/off}$, change over the standby terminal by the voltages of 0 V and 5 V at the time shown below.

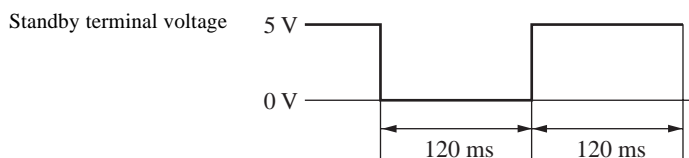

■ Usage Notes

1. Always attach an outside heat sink when using the chip. Note that, the outside heat sink must be fastened onto a chassis for use.
2. Connect the cooling fin to GND potential.
3. Avoid short circuit to V_{CC} and short circuit to GND, and load short-circuit.
4. The temperature protection circuit will be actuated at $T_j =$ approx. 150°C , but it is automatically reset when the chip temperature drops below the above set level.
5. The overvoltage protection circuit starts its operation at $V_{CC} =$ approx. 20 V .
6. Take into consideration the heat radiation design particularly when V_{CC} is set high or when the load is $2\ \Omega$.
7. When the beep sound function is not used, open the beep sound input pin (pin 10) or connect it to pin 9 with around $0.01\ \mu\text{F}$ capacitor.
8. Connect only pin 9 (ground, signal source) to the signal GND of the amplifier in the previous stage. The characteristics such as distortion, etc. will improve.

■ Technical Information

- $P_D - T_a$ curves of packages

- HZIP016-P-0665A (AN7190NK)

$P_D - T_a$

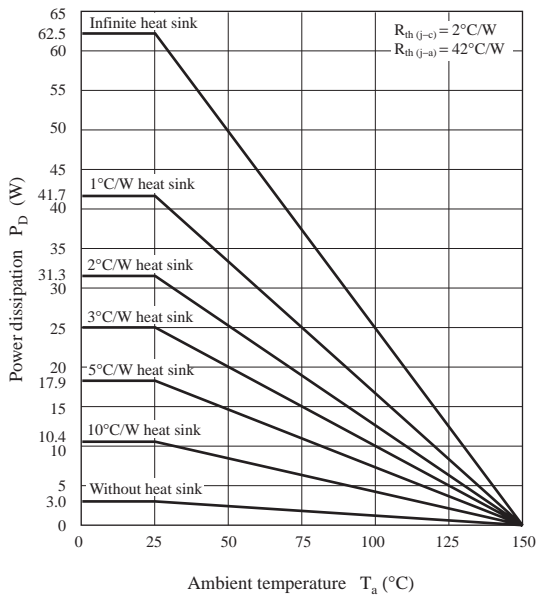

- HZIP015-P-0745A (AN7190NZ)

$P_D - T_a$

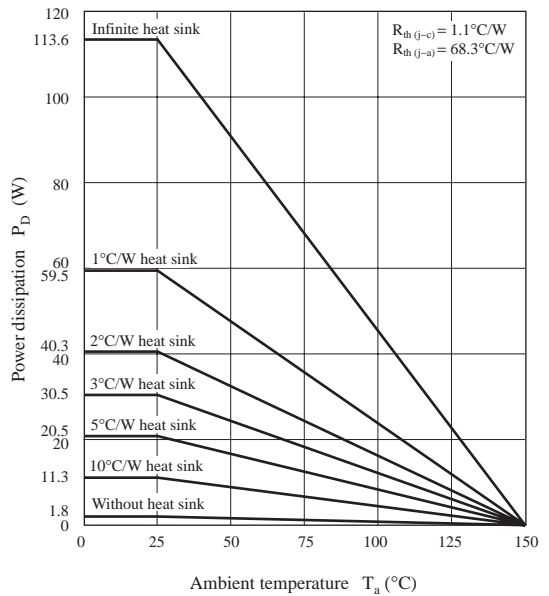

■ Application Circuit Example

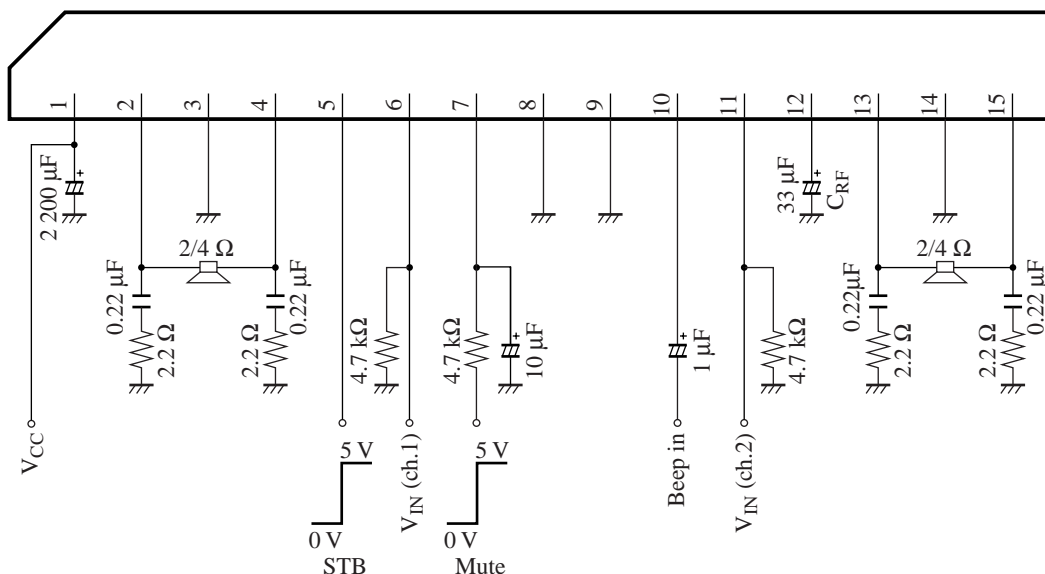

Note) Standby state when STB pin is open-circuit.

Mute off when mute terminal is open-circuit.

Replace the C_{RF} with $10\ \mu\text{F}$ capacitor when shock noise (V_S) is measured.



LittleDiode supplies new, hard to find or obsolete electronic components and semiconductors all over the world.

With over two million different components listed you are sure to find the part you need.

Feel free to visit us today at our online store:

LittleDiode.com

Looking forward to providing you with the best possible service.