

AN7196K

Dual 15 W BTL power IC for car audio

■ Overview

The AN7196K is an audio power IC developed for the sound output of car audio (dual 15 W). Especially, this circuit has solved the problem of heat radiation design inherent to a single chip IC with 4-channel audio outputs and realized a corresponding space saving at the same time.

In addition, it is incorporating various protection circuits to protect the IC from destruction by GND-open short-circuit to GND and power supply surge which are the most important subjects of power IC protection, and the IC will largely contribute to a high reliability design of equipment.

It is also incorporating the industry's first perfect muting circuit, which is free from shock noise, so that a shock noise design under the set transient condition can be made easily when the muting circuit is used together with its standby function.

The AN7196K is pin compatible with the AN7191NK (dual 20 W), so that the identical pattern design is allowed for high-class types as well as popular types.

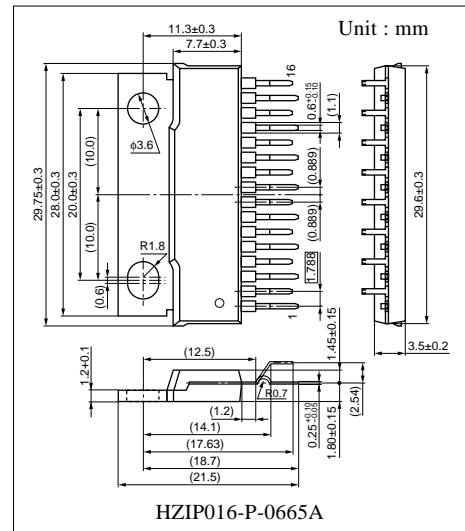

■ Features

- Built-in various protection circuits (realizing high breakdown voltage against destruction)
 - Power supply surge breakdown voltage of 100 V or more
 - Ground open breakdown voltage of 16 V or more
- Built-in standby function (free from shock noise at standby on/off)
- Built-in muting function (the industry's first)
 - Free from shock noise at mute-on/off
 - Adapting attenuator method so that abnormal sound due to waveform deformation is not generated
 - Attack time, recovery time of 50 ms or less
- Space saving design is possible with a small size package
 - A heat radiation design that has been a problem particularly in a 4-ch. single chip IC can be done by the conventional method.
- Reduction in external components (parts reduction to half compared with the AN7176K)
 - It eliminates the need for NF and BS electrolytic capacitors,
 - Muting function is unnecessary
 - Power supply choke coil is unnecessary
- Provided with beep sound input pin
- Pin compatible with the AN7191NK (dual 20 W)

■ Applications

- Car audio

■ Block Diagram

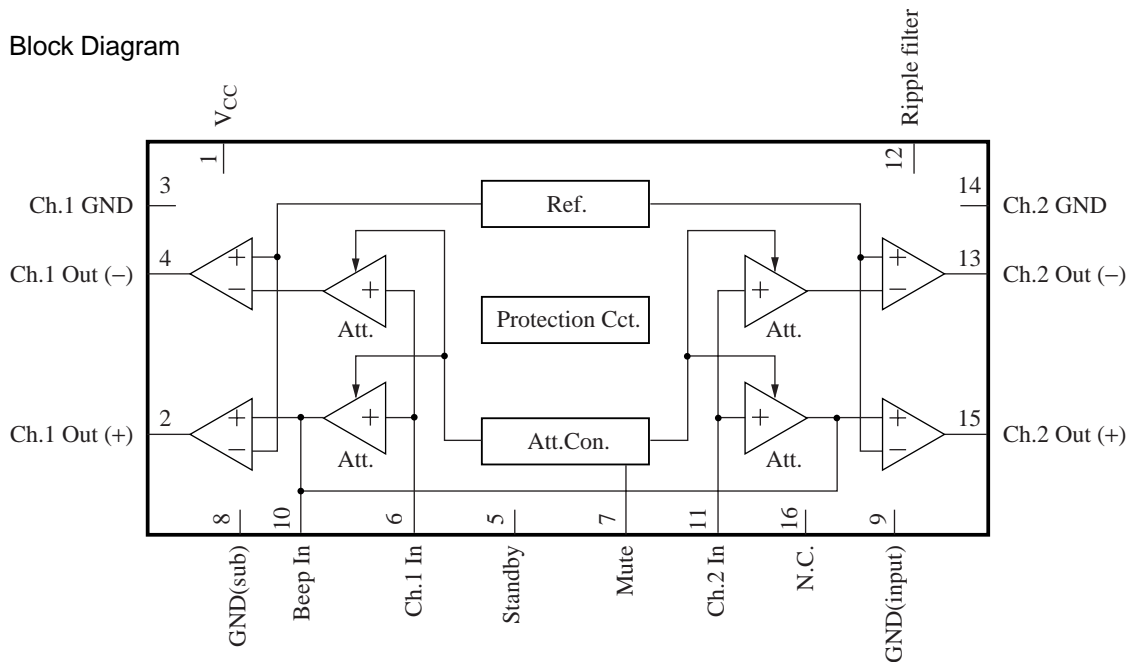

■ Pin Descriptions

Pin No.	Description	Pin No.	Description
1	Power supply	9	Grounding (input)
2	Ch.1 output (+)	10	Beep sound input
3	Grounding (output ch.1)	11	Ch.2 input
4	Ch.1 output (-)	12	Ripple filter
5	Standby	13	Ch.2 output (-)
6	Ch.1 input	14	Grounding (output ch.2)
7	Muting	15	Ch.2 output (+)
8	Grounding (sub)	16	N.C.

■ Absolute Maximum Ratings

Parameter	Symbol	Rating	Unit
Supply voltage ^{*2}	V _{CC}	25	V
Peak supply voltage ^{*3}	V _{surge}	80	V
Supply current	I _{CC}	9.0	A
Power dissipation ^{*4}	P _D	59	W
Operating ambient temperature ^{*1}	T _{opr}	-30 to +85	°C
Storage temperature ^{*1}	T _{stg}	-55 to +150	°C

Note) *1 : All items are at T_a = 25°C, except for the operating ambient temperature and storage temperature.

*2 : Without signal

*3 : Time = 0.2 s

*4 : T_a = 85°C

■ Recommended Operating Range

Parameter	Symbol	Range	Unit
Supply voltage	V_{CC}	8.0 to 18.0	V

■ Electrical Characteristics at $V_{CC} = 13.2$ V, $f = 1$ kHz, $T_a = 25^\circ\text{C}$

Parameter	Symbol	Conditions	Min	Typ	Max	Unit
Quiescent current	I_{CQ}	$V_{IN} = 0$ mV, $R_L = 4 \Omega$	—	120	250	mA
Standby current	I_{STB}	$V_{IN} = 0$ mV, $R_L = 4 \Omega$	—	1	10	μA
Output noise voltage *1	V_{NO}	$R_g = 4.7$ k Ω , $R_L = 4 \Omega$	—	0.22	0.5	mV[rms]
Voltage gain 1	G_{V1}	$V_{IN} = 40$ mV, $R_L = 4 \Omega$	32	34	36	dB
Total harmonic distortion 1	THD_1	$P_O = 0.5$ W, $R_L = 4 \Omega$	—	0.07	0.4	%
Maximum output power 1	P_{O1}	$THD = 10\%$, $R_L = 4 \Omega$	12	14	—	W
Ripple rejection ratio *1	RR	$R_L = 4 \Omega$, $R_g = 4.7$ k Ω , $V_r = 1$ V[rms], $f_r = 1$ kHz	60	70	—	dB
Channel balance	CB	$V_{IN} = 40$ mV, $R_L = 4 \Omega$	—	0	1	dB
Cross-talk *1	CT	$V_{IN} = 40$ mV, $R_L = 4 \Omega$, $R_g = 4.7$ k Ω	55	65	—	dB
Output offset voltage	V_{Off}	$R_g = 4.7$ k Ω , $R_L = 4 \Omega$	-250	0	250	mV
Muting effect *1	MT	$V_{IN} = 40$ mV, $R_L = 4 \Omega$	70	82	—	dB
Input impedance	Z_i	$V_{IN} = \pm 0.3$ V _{DC}	22	28	35	k Ω
Voltage gain 2	G_{V2}	$V_{IN} = 40$ mV, $R_L = 2 \Omega$	32	34	36	dB
Total harmonic distortion 2	THD_2	$P_O = 0.5$ W, $R_L = 2 \Omega$	—	0.1	0.5	%
Maximum output power 2	P_{O2}	$THD = 10\%$, $R_L = 2 \Omega$	12	20	—	W
Shock noise *2	V_S	$R_L = 4 \Omega$, $R_g = 4.7$ k Ω $V_{STB} = \text{on/off}$, 50 Hz HPF-on	-100	0	100	mV[p-0]
Total harmonic distortion 3	THD_3	$V_{IN} = 10$ mV, $f_{IN} = 20$ kHz $R_g = 4.7$ k Ω , $R_L = \infty$	—	0.10	0.5	%

Note) *1 : Measurement using a bandwidth 15 Hz to 30 kHz (12 dB/OCT) filter.

*2 : For $V_{STB} = \text{on/off}$, change over the standby terminal by the voltages of 0 V and 5 V at the time shown below.

Standby terminal voltage

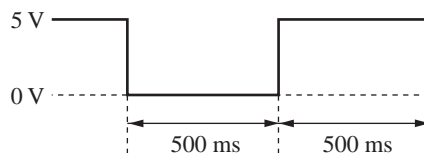

■ Usage Notes

1. Always attach an outside heat sink to use the chip. In addition, the outside heat sink must be fastened onto a chassis for use.
2. Connect the cooling fin to GND potential.
3. Avoid short-circuit to V_{CC} and short-circuit to GND, and load short-circuit.
4. The temperature protection circuit will be actuated at $T_j = \text{approx. } 150^\circ\text{C}$, but it is automatically reset when the chip temperature drops below the above set level.
5. The overvoltage protection circuit starts its operation at $V_{CC} = \text{approx. } 20\text{ V}$.
6. Take into consideration the heat radiation design particularly when V_{CC} is set high or when the load is $2\ \Omega$.
7. When the beep sound function is not used, open the beep sound input pin (pin 10) or connect it to pin 9 with around $0.01\ \mu\text{F}$ capacitor.
8. Connect only pin 9 (ground, signal source) to the signal GND of the amplifier in the previous stage. The characteristics such as distortion, etc. will be improved.

■ Technical Information

- $P_D - T_a$ curves of HZIP016-P-0665A

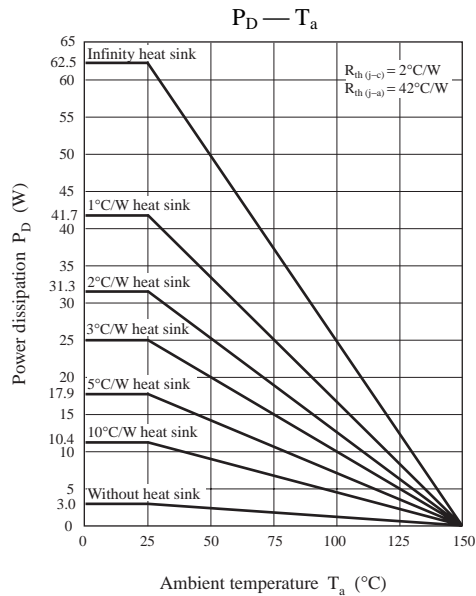

■ Application Circuit Example

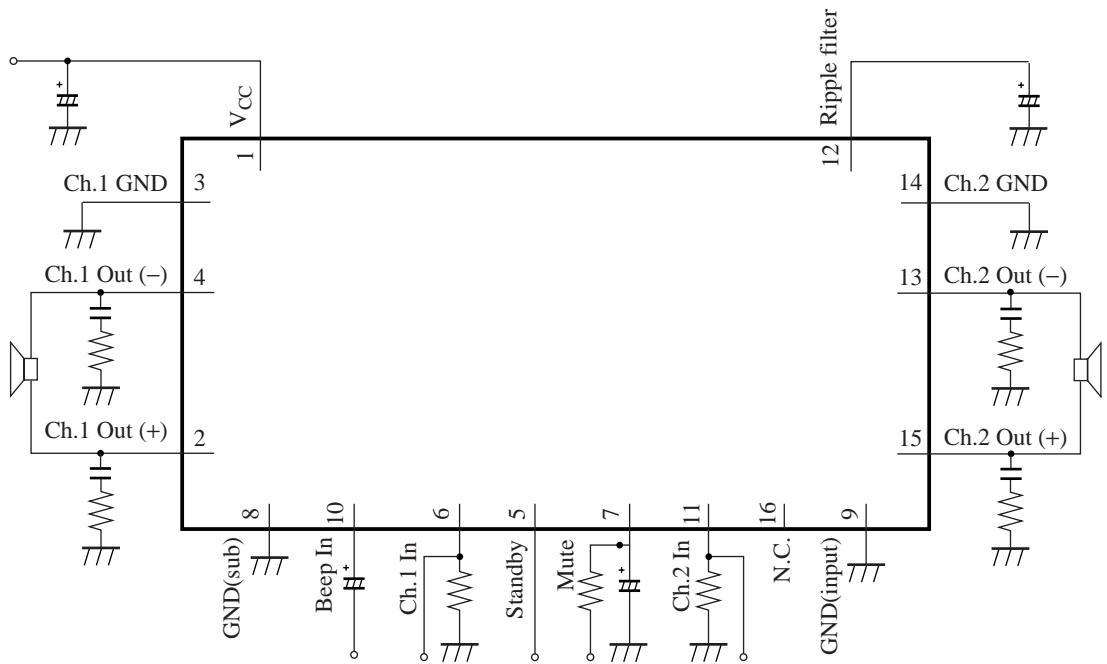



LittleDiode supplies new, hard to find or obsolete electronic components and semiconductors all over the world.

With over two million different components listed you are sure to find the part you need.

Feel free to visit us today at our online store:

LittleDiode.com

Looking forward to providing you with the best possible service.