

AN7198Z

Dual 20 W BTL Power IC for Car Audio

■ Overview

The AN7198Z is an audio power IC developed for the sound output of car audio (Dual 20 W).

A capacitor and a resistor between the output pin and GND to stop oscillation are built-in so that a space saving of set is possible. Also, it incorporates an industry's first superior muting circuit which is free from shock noise, so that a shock noise design under the set transient condition can be made easily when the muting circuit is used together with its standby function.

In addition, it is incorporating various protective circuits to protect the IC from destruction by GND-open short circuit to GND and power supply surge which are the important subjects of power IC protection, and the IC will largely contribute to a high reliability design of equipment.

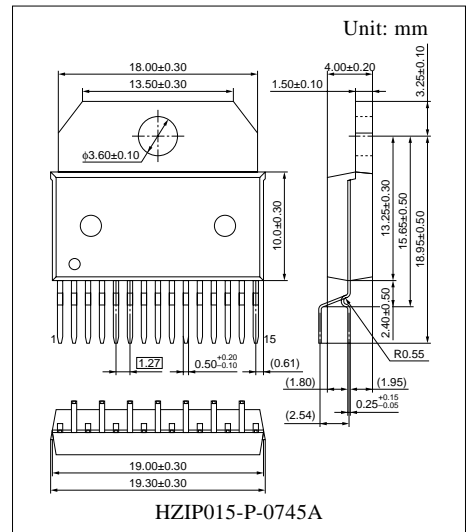

■ Features

- Built-in various protection circuits (Realizing high breakdown voltage against destruction)
 - Power supply surge breakdown voltage of 80 V or more
 - Ground-open breakdown voltage of 16 V or more
- Built-in standby function (Free from shock noise at STB-on/off)
- Built-in muting function
 - Free from shock noise at mute-on/off
 - Adapting attenuator method, so that abnormal sound due to waveform deformation is not generated
 - Attack time, recovery time of 50 ms or less
- Reduction in external components
 - No capacitors and resistors for oscillation stop are unnecessary
 - It eliminates the need for NF and BS electrolytic capacitors
 - Muting function is unnecessary
 - Power supply choke coil is unnecessary
- Provided with beep sound input pin
- High sound quality design

■ Applications

- Car audio

■ Block Diagram

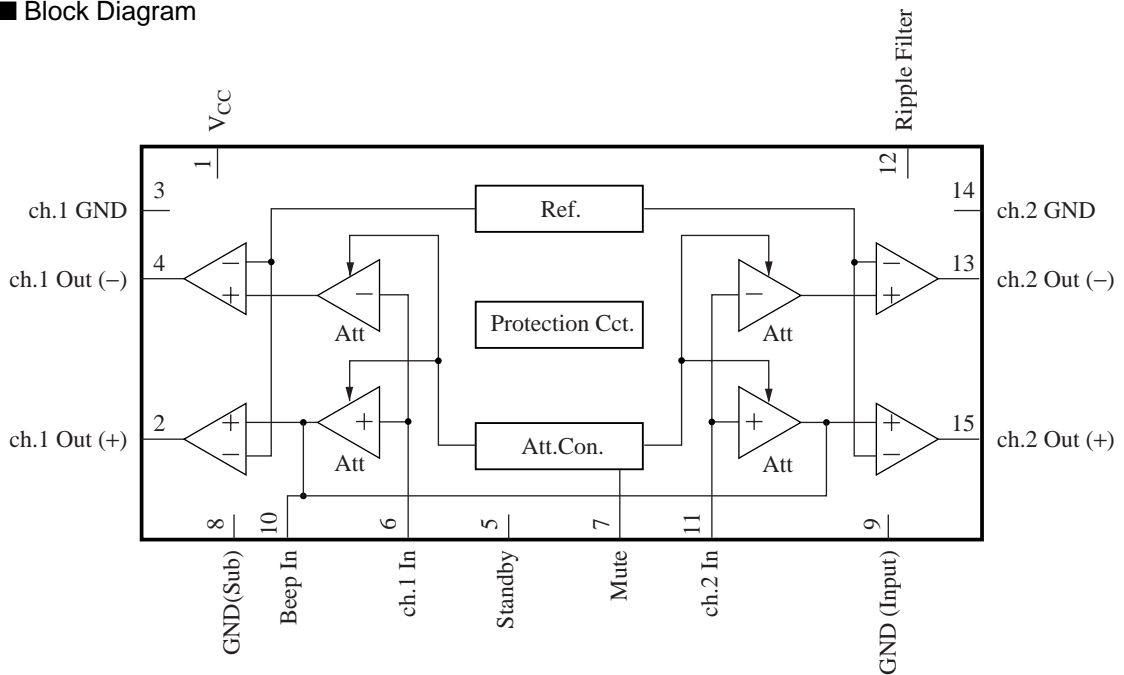

■ Pin Description

Pin No.	Description	Pin No.	Description
1	Power supply	9	Grounding (input)
2	Ch.1 output (+)	10	Beep sound input
3	Grounding (output ch.1)	11	Ch.2 input
4	Ch.1 output (-)	12	Ripple filter
5	Standby	13	Ch.2 output (-)
6	Ch.1 input	14	Grounding (output ch.2)
7	Muting	15	Ch.2 output (+)
8	Grounding (board)		

■ Absolute Maximum Ratings

Parameter	Symbol	Ratings	Unit
Supply voltage *2	V _{CC}	25	V
Peak supply voltage *3	V _{surge}	60	V
Supply current	I _{CC}	9.0	A
Power dissipation *4	P _D	59	W
Operating ambient temperature *1	T _{opr}	- 30 to + 85	°C
Storage temperature *1	T _{stg}	- 55 to + 150	°C

Note) *1: T_a = 25°C except operating ambient temperature and storage temperature.

*2: Without signal

*3: Time = 0.2 s

*4: T_a = 85°C

■ Recommended Operating Range

Parameter	Symbol	Ratings	Unit
Supply voltage	V_{CC}	8.0 to 18.0	V

■ Electrical Characteristics at $V_{CC} = 13.2$ V, $f = 1$ kHz, $T_a = 25^\circ\text{C}$

Parameter	Symbol	Conditions	Min	Typ	Max	Unit
Quiescent current	I_{CQ}	$V_{IN} = 0$ mV, $R_L = 4 \Omega$	—	150	250	mA
Standby current	I_{STB}	$V_{IN} = 0$ mV, $R_L = 4 \Omega$	—	1	10	μA
Output noise voltage *1	V_{NO}	$R_g = 10$ k Ω , $R_L = 4 \Omega$	—	0.18	0.5	mV[rms]
Voltage gain 1	G_{V1}	$V_{IN} = 40$ mV, $R_L = 4 \Omega$	32	34	36	dB
Total harmonic distortion 1	THD_1	$V_{IN} = 40$ mV, $R_L = 4 \Omega$	—	0.05	0.4	%
Maximum output power 1	P_{O1}	THD = 10%, $R_L = 4 \Omega$	16	18.5	—	W
		$V_{CC} = 14.4$ V, $R_L = 4 \Omega$	—	22.0	—	W
Ripple rejection ratio *1	RR	$R_L = 4 \Omega$, $R_g = 10$ k Ω , $V_r = 1$ V[rms] $f_r = 1$ kHz	60	65	—	dB
Channel balance	CB	$V_{IN} = 40$ mV, $R_L = 4 \Omega$	—	0	1	dB
Cross-talk *1	CT	$V_{IN} = 40$ mV, $R_L = 4 \Omega$, $R_g = 10$ k Ω	60	79	—	dB
Output offset voltage	V_{Off}	$R_g = 10$ k Ω , $R_L = 4 \Omega$	-250	0	250	mV
Muting effect *1	MT	$V_O = 1$ W, $R_L = 4 \Omega$	70	86	—	dB
Input impedance	Z_i	$V_{IN} = \pm 0.3$ V _{DC}	24	30	36	k Ω
Voltage gain 2	G_{V2}	$V_{IN} = 40$ mV, $R_L = 2 \Omega$	32	34	36	dB
Total harmonic distortion 2	THD_2	$V_{IN} = 40$ mV, $R_L = 2 \Omega$	—	0.08	0.5	%
Maximum output power 2	P_{O2}	THD = 10%, $R_L = 2 \Omega$	16	28	—	W
Shock noise *2	V_S	$R_L = 4 \Omega$, $R_g = 10$ k Ω , $V_{MUTE} = 5$ V $V_{STB} = \text{on/off}$, 50 Hz HPF-on	-100	0	100	mV[p-0]
Total harmonics distortion 3	THD_3	$V_{IN} = 20$ mV, $f_{IN} = 20$ kHz $R_g = 10$ k Ω , $R_L = \infty$	—	0.10	0.5	%

Note) *1: Measurement using a bandwidth 15 Hz to 30 kHz (12 dB/OCT) filter.

*2: For $V_{STB} = \text{on/off}$ change over the standby terminal by the voltage of 0 V and 5 V at the time shown below.

Standby terminal voltage

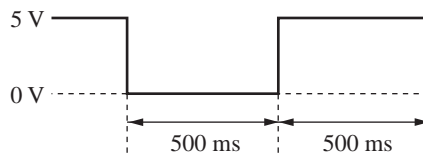

■ Terminal Equivalent Circuits

Pin No.	Equivalent circuits	Description	DC voltage
1	—	Supply voltage connection pin Power supply connection pin	13.2 V
2		Ch.1 output pin (+) Ch.1 positive-phase output pin	6.3 V
3	—	GND (Output) Grounding pin for ch.1 output	0 V
4		Ch.1 output pin (-) Ch.1 inverted-phase output pin	6.3 V
5		Standby control pin Standby changeover pin Threshold voltage approx. 2.1 V	
6		Ch.1 input pin Ch.1 input signal applied pin Input impedance 30 kΩ	0 mV to 10 mV

■ Terminal Equivalent Circuits (continued)

Pin No.	Equivalent circuits	Description	DC voltage
7		Mute control pin Mute changeover pin Threshold voltage approx. 2.1 V	—
8	—	GND (substrate) Substrate	0 V
9	—	GND (input) Grounding pin for input	0 V
10		Beep sound input pin Beep sound signal input pin Input impedance 15.3 kΩ	2.1 V
11		Ch.2 input pin Ch.2 input signal applied pin Input impedance 30 kΩ	0 mV to 10 mV
12		Ripple filter pin Output current 3 mA to 10 mA	13.0 V

■ Terminal Equivalent Circuits (continued)

Pin No.	Equivalent circuits	Description	DC voltage
13		Ch.2 output pin (-) Ch.2 inverted-phase output pin	6.3 V
14	—	GND (output) Grounding pin for ch.2 output	0 V
15		Ch.2 output pin (+) Ch.2 positive-phase output pin	6.3 V

■ Usage Notes

1. Always attach an outside heat sink to use the chip. In addition, the outside heat sink must be fastened onto a chassis for use.
2. Connect the cooling fin to GND potential.
3. Avoid short-circuit to V_{CC} and short circuit to GND, and load short-circuit. There is a danger of destruction under a special condition.
4. The temperature protection circuit will be actuated at $T_j =$ approx. 150°C , but it is automatically reset when the chip temperature drops below the above set level.
5. The overvoltage protection circuit starts its operation at $V_{CC} =$ approx. 20 V.
6. Take into consideration the heat radiation design particularly when V_{CC} is set high or when the load is $2\ \Omega$.
7. When the beep sound function is not used, open the beep sound input pin (pin10) or connect it to pin 9 with around $0.01\ \mu\text{F}$ capacitor.
8. Connect only pin 9 (ground, signal source) to the signal GND of the amplifier in the previous stage. The characteristics such as distortion, etc. will be improved.

■ Technical Information

1. P_D — T_a Curves of HZIP015-P-0745A

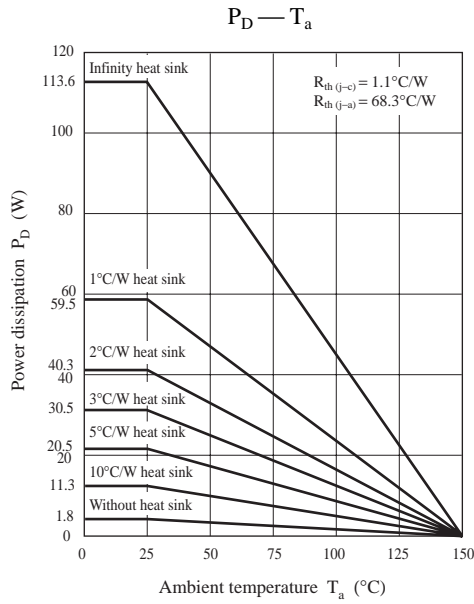

2. Main Characteristics

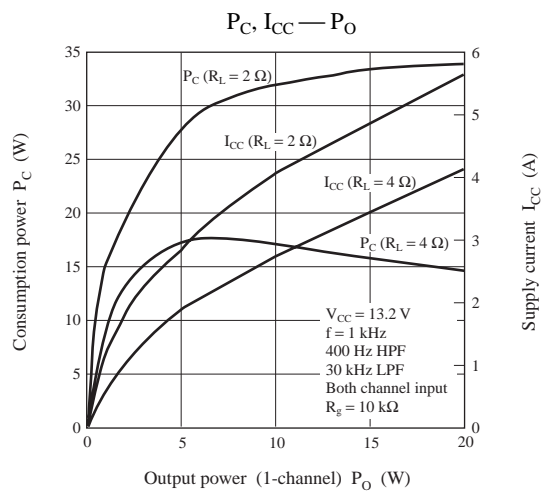
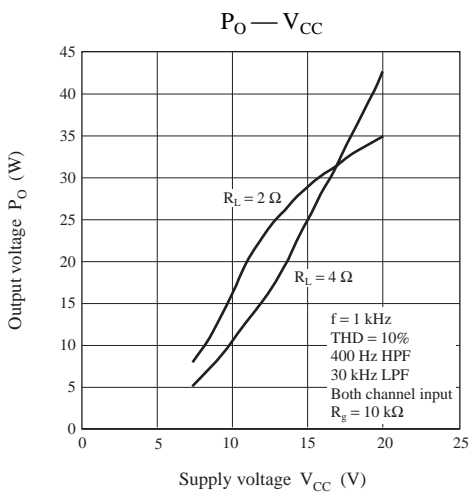

■ Technical Information (continued)

2. Main Characteristics (continued)

P_O , THD — V_{IN} ($R_L = 4 \Omega$)

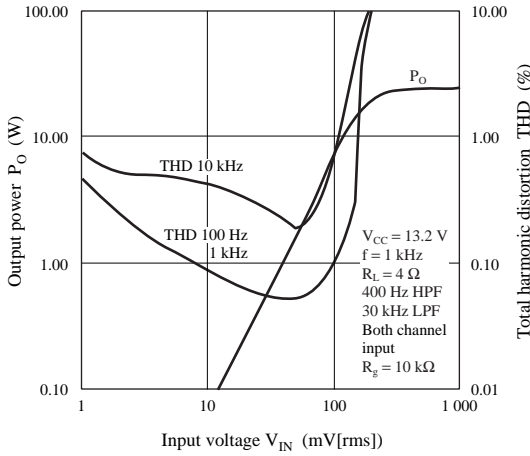

P_O , THD — V_{IN} ($R_L = 2 \Omega$)

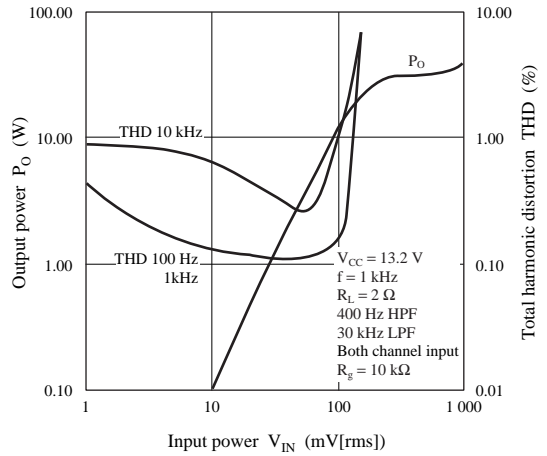

G_V , P_O — f

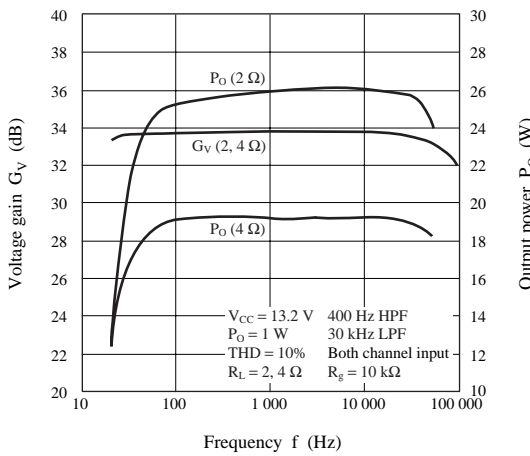

THD — f

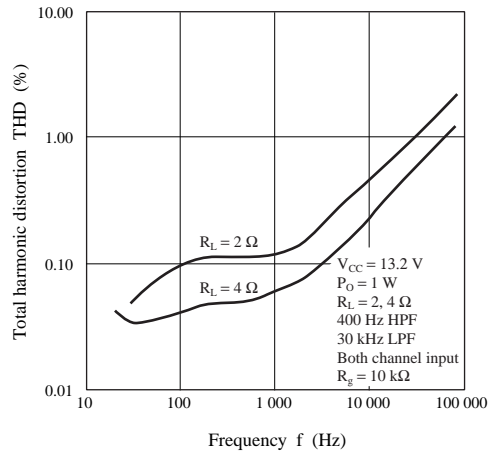

G_V , THD — V_{CC}

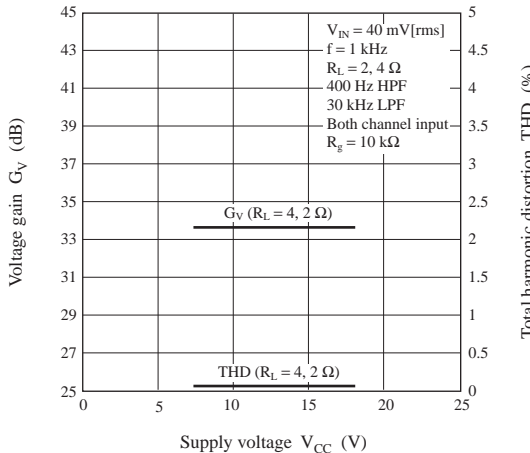

I_{CQ} , I_{STB} — V_{CC}

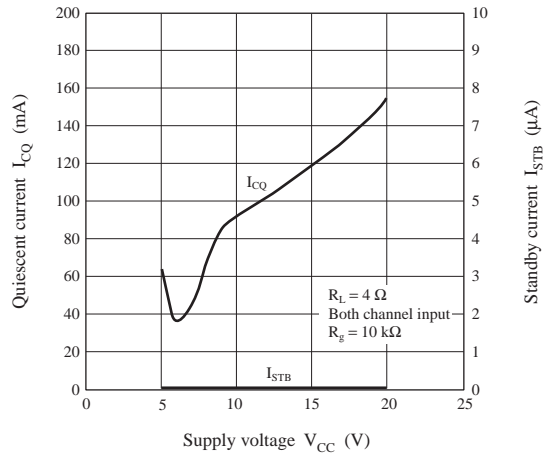

■ Technical Information (continued)

2. Main Characteristics (continued)

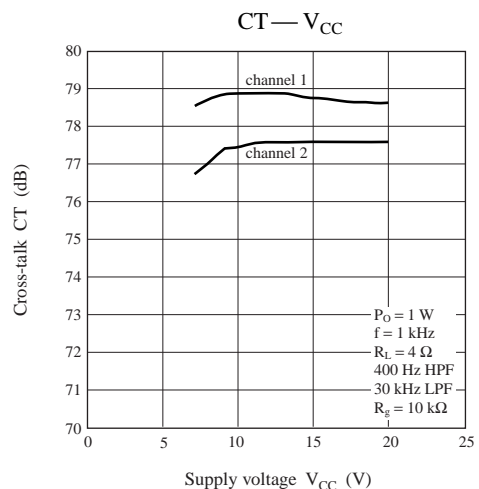
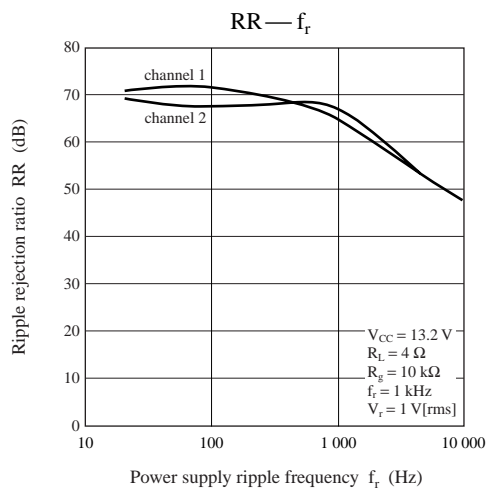
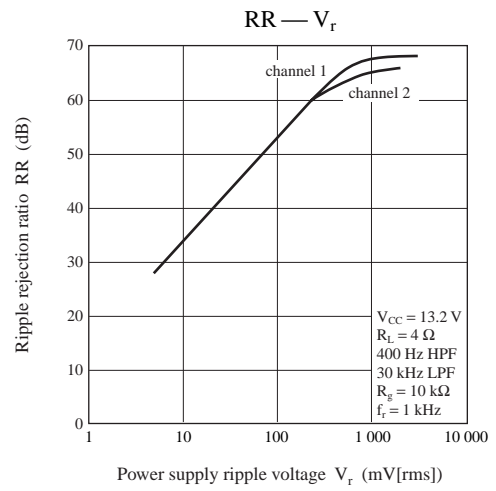
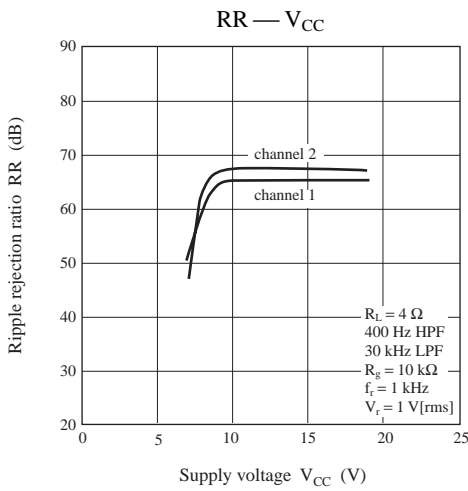
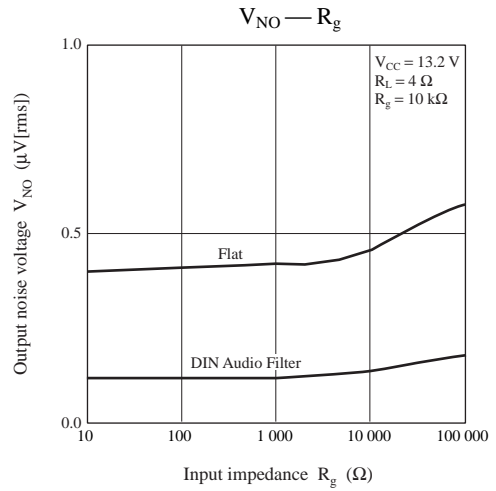
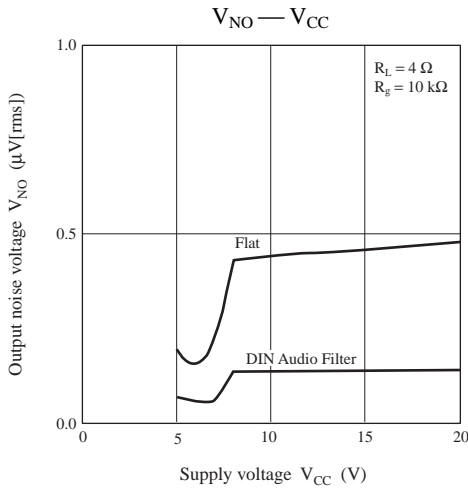

■ Technical Information (continued)

2. Main Characteristics (continued)

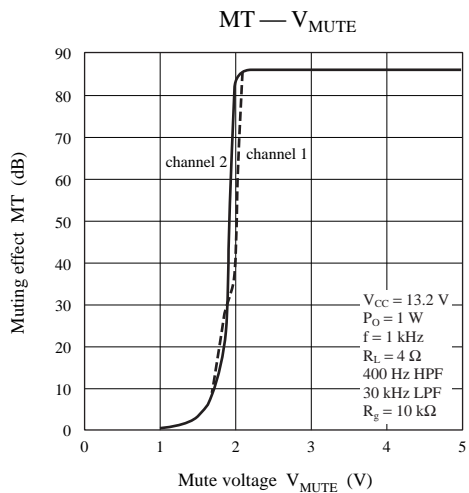
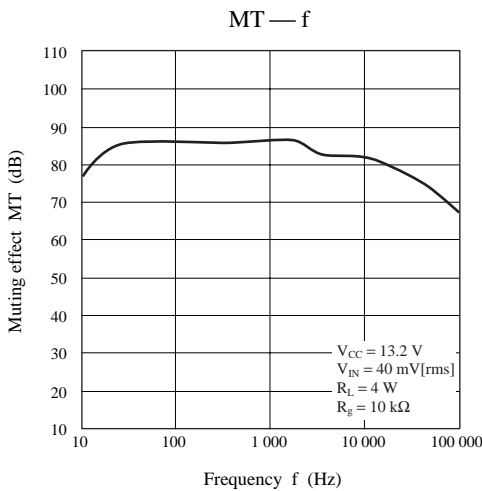
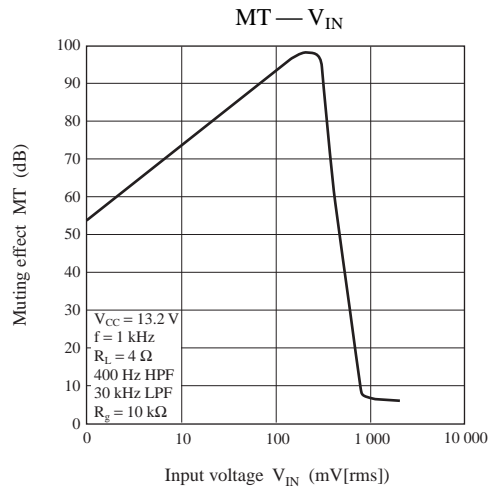
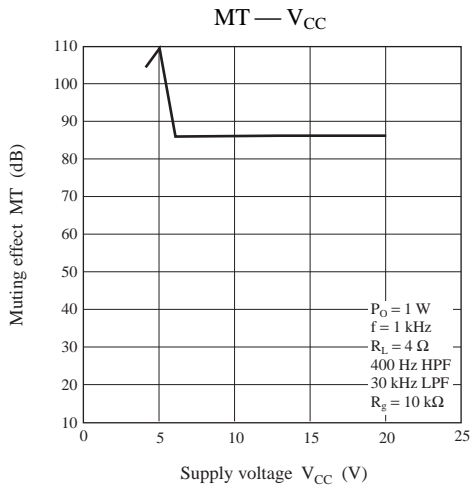
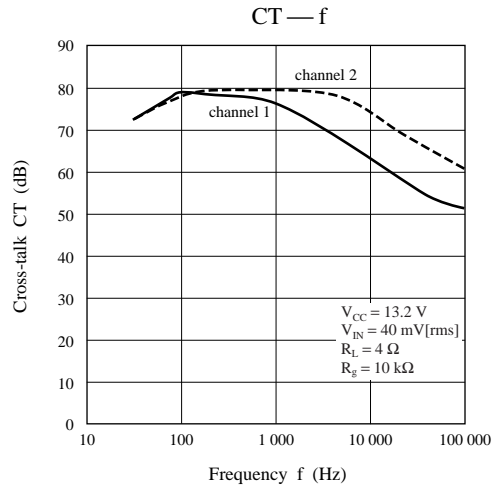
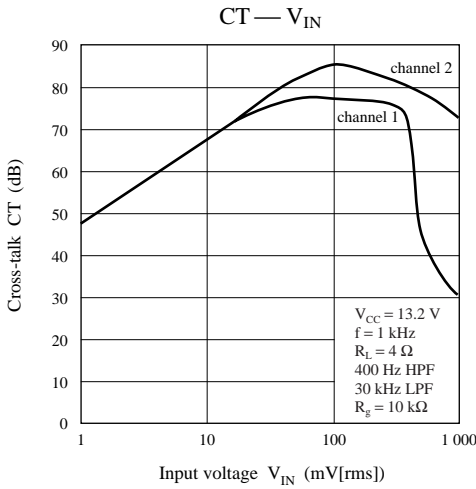

■ Technical Information (continued)

2. Main Characteristics (continued)

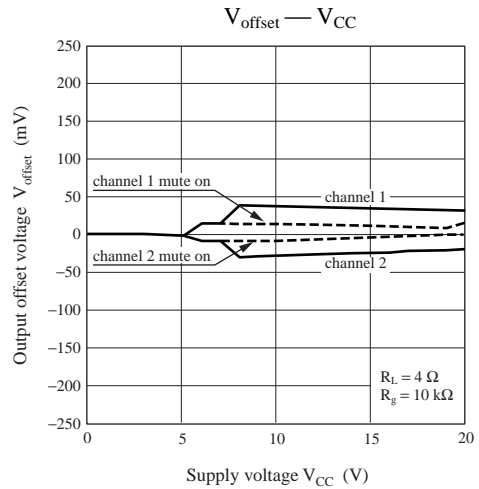
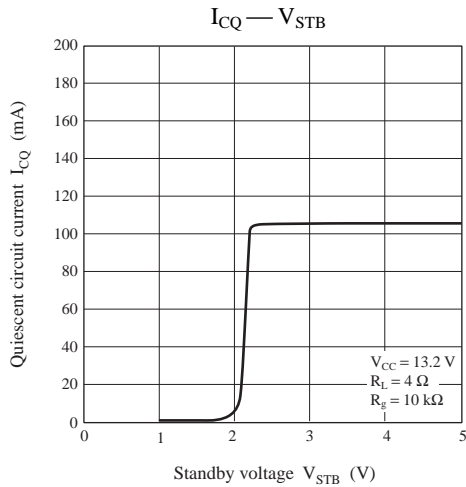

3. Application note

1) Standby function

- (1) The power can be turned on or off by making pin 5 (standby terminal) high or low.
- (2) The standby terminal has threshold voltage of approx. 2.1 V, however, it has temperature dependency of approx. $-6 \text{ mV}/^\circ\text{C}$. The recommended range of use is shown in Table 1.
- (3) The internal circuit of standby terminal is as shown in Figure 1. When the standby terminal is high, the current approximately expressed by the following equation will flow into the circuit.

$$I_{STB} = \frac{V_{STB} - 2.7 \text{ V}}{10 \text{ k}\Omega} \text{ [mA]}$$

Terminal state	Terminal voltage	Power
Open	0 V	Standby state
Low	0 V to 1.0 V	Standby state
High	Higher than 3 V	Operating state

Table 1

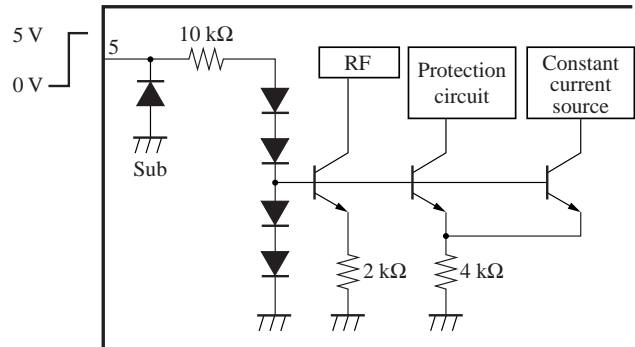

Figure 1

- (4) A power supply with no ripple component should be used for the control voltage of standby terminal.

■ Technical Information (continued)

3. Application note (continued)

2) Output line noise countermeasures

(1) In order to increase the oscillation allowance, it is unnecessary to use a capacitor and a resistor between each output terminal and GND. However, when inserting the capacitor for countermeasures against output line noise between the output terminal and GND, insert a resistor of approx. $2.2\ \Omega$ in series as shown in Figure 2. The oscillation may occur if only capacitor is used. Use it after giving a sufficient evaluation.

(2) The use of polyester film capacitor having a little fluctuation with temperature and frequency is recommended as the capacitor for countermeasures against output line noise.

3) Input terminal

(1) The reference voltage of input terminal is 0 V. When the input signal has a reference voltage other than 0 V potential, connect a coupling capacitor (of about several μF) for DC component cut in series with the input terminal. Check the low-pass frequency characteristics to determine the capacitor value.

(2) $10\ \text{k}\Omega$ or less of signal source impedance R_g can reduce the output end noise voltage.

(3) The output offset voltage fluctuates when the signal source impedance R_g is changed. A care must be taken in the case of using the circuit by directly connecting a volume control to the input terminal. In such a case, the use of coupling capacitor is recommended.

(4) If a high frequency signal from tuners enters the input terminal as noise, insert a capacitor of approx. $0.01\ \mu\text{F}$ between the input terminal and input GND.

When a high frequency signal is inputted, malfunction in protective circuits may occur.

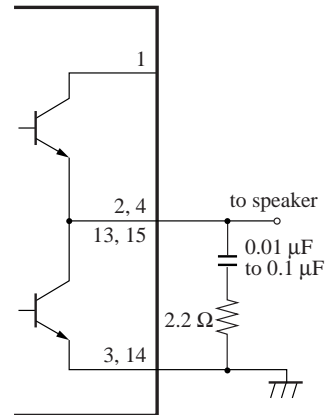

Figure 2

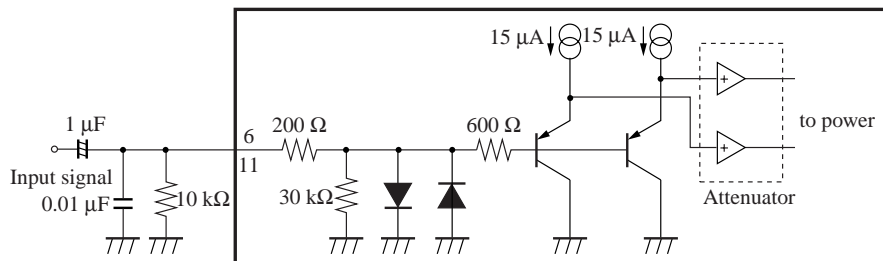

Figure 3

4) Ripple filter

(1) In order to suppress the fluctuation of supply voltage, connect a capacitor of approx. $33\ \mu\text{F}$ between RF terminal (pin 12) and GND.

(2) Relation between RR (Ripple Rejection Ratio) and a capacitor.

The larger the capacitance of the ripple filter is, the better the ripple rejection ratio becomes.

(However, there is almost no difference if the capacitance is $10\ \mu\text{F}$ or more.)

■ Technical Information (continued)

3. Application note (continued)

4) Ripple filter (continued)

- (3) Relation between the rise time of circuit and a capacitor.
The larger the capacitance of the ripple filter is, the longer the time from the power on (STB-high) to the sound release becomes.
- (4) The DC voltage of output terminal is approximately the middle point of the ripple filter terminal voltage.
- (5) The internal circuit of ripple filter terminal is as shown in Figure 5 and the charge current is approx. 3 mA to 10 mA.
- (6) After the power supply is turned off (STB-low), it takes 10 seconds or less for the total circuit current to become the standby current (under 10 μ A). If approx. 47 k Ω resistor is inserted between the ripple filter terminal and GND for the purpose of reducing the inspection time with set, a time until the current becomes the standby current can be shortened.

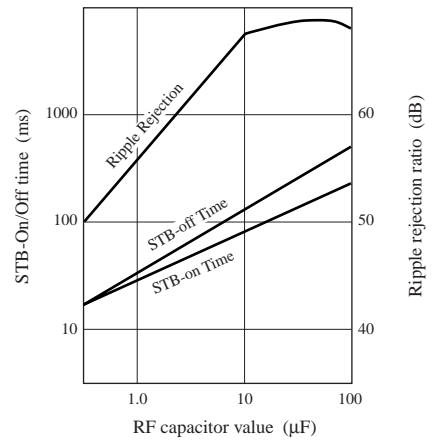

Figure 4

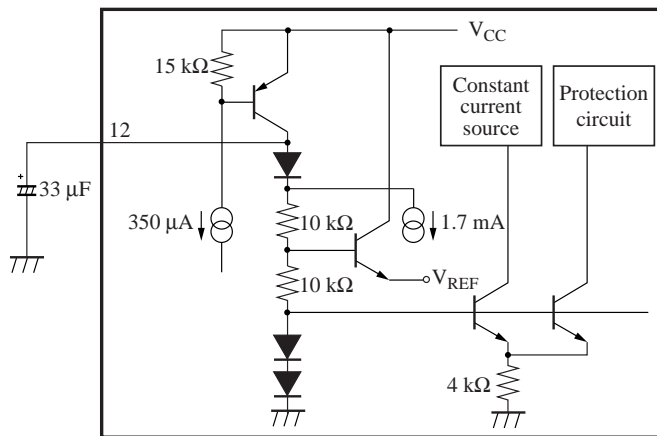

Figure 5

5) GND terminal

- (1) Be sure to short-circuit each GND terminal of pin 3, 8, 9 and 14 at a point outside the IC in use.
- (2) For each GND terminal, the one-point earth, referenced to the GND connection point of electrolytic capacitor between the supply terminal and GND, is most effective for reducing the distortion. Even in the worst case, ground pin 8, 9 of input GND separately from all the other GND terminals.
- (3) Each GND terminal is not electrically short-circuited inside. Only pin 8 is connected with the substrate.
- (4) Pin 9 is input signal GND. Connect only pin 9 with GND of the input.

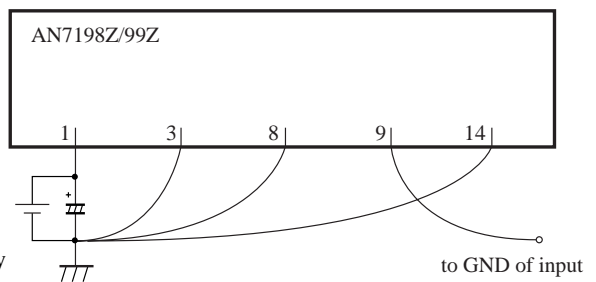

Figure 6

■ Technical Information (continued)

3. Application note (continued)

6) Cooling fin

- (1) The cooling fin is not connected with GND terminal by using Au wire. Only pin 8 is electrically connected through the substrate.
- (2) Always attach an outside heat sink to the cooling fin. The cooling fin must be fastened onto a chassis for use. Otherwise, IC lead failure may occur.
- (3) Do not give the cooling fin any potential other than the GND potential. Otherwise, it may cause breakdown.
- (4) Connection of the cooling fin with GND can reduce the incoming noise hum. (It is unnecessary to connect with GND in use, but connect it with the power GND when the cooling fin is connected with GND)

7) Shock noise

(1) STB on/off

Turn on the mute circuit when switching over to the standby.

No shock noise is released when the mute on state. However, the changeover switch of the standby terminal may make a slight shock noise. In such a case, insert a capacitor of approx. 0.01 μF between the standby terminal and GND.

(2) Mute on/off

No shock noise is released. Refer to the section on the mute function.

8) Mute function

- (1) The mute-On/Off is possible by making pin 7 (the muting terminal) high or to low.
- (2) The muting circuit is as shown in Figure 7. The amplifier gain including attenuator block is given in the following equation:

$$G_V = \frac{I_1}{I_2} \times \underbrace{50}_{\text{Original gain}}$$

From the above equation, the amplifier gain can be made as 0 time by setting I_1 at 0 mA at muting.

- (3) The threshold voltage of V_{MUTE} is as follows:

Mute-off approx. 1 V or less
Mute-on approx. 3 V or more

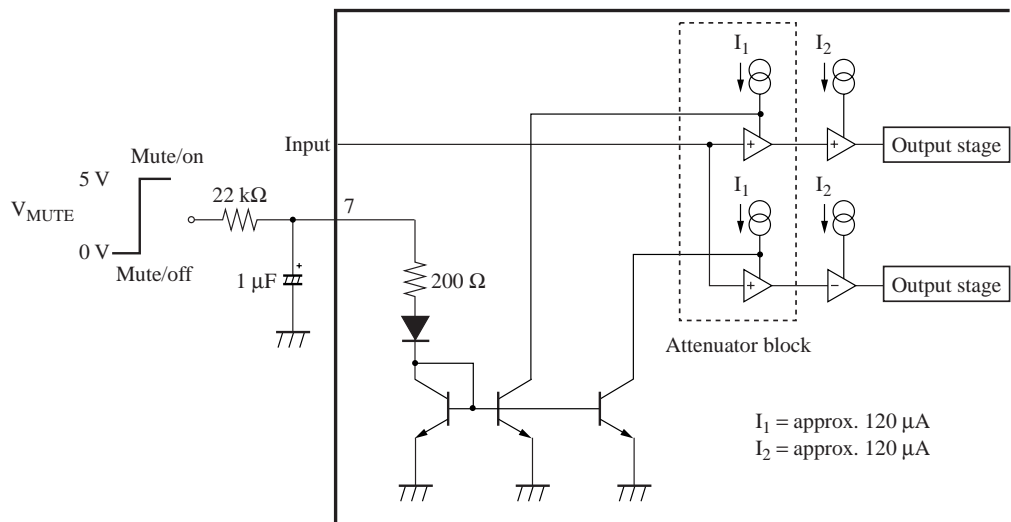

Figure 7

■ Technical Information (continued)

3. Application note (continued)

8) Mute function (continued)

(4) Attack time and recovery time can be changed by the external CR of pin 7. For recommended circuits (Figure 7 22 kΩ , 1 μF), the above mentioned times are as follows:

Attack time: Approx. 30 ms

Recovery time: Approx. 40 ms

However, the control voltage of V_{MUTE} is assumed to be 5 V. When it is not directly controlled by microcomputer (5 V), (such as 13.2 V separate power supply), it is necessary to change CR values because the above times change.

(5) When the attack time and recovery time are set at 20 ms or less, pay attention to the IC with larger output offset because it may release the shock noise.

9) Voltage gain

The voltage gain is fixed at 34 dB for the AN7198Z, and 40 dB for the AN7199Z. It is not possible to change those values by the addition of an external resistance.

10) Beep sound input function

(1) The application circuit example when using the beep sound input is shown in Figure 8. Connect the beep signals from the microcomputer to pin 10 via the capacitor C1 for DC cut and the resistor R1 for voltage gain adjustment.

(2) The voltage gain of beep sound terminal is approx. -6.2 dB.

The setting value of Figure 8 becomes approx. -19.7 dB (f = 1 kHz).

(3) The beep sound is outputted to the output terminals, pin 2 and pin 15.

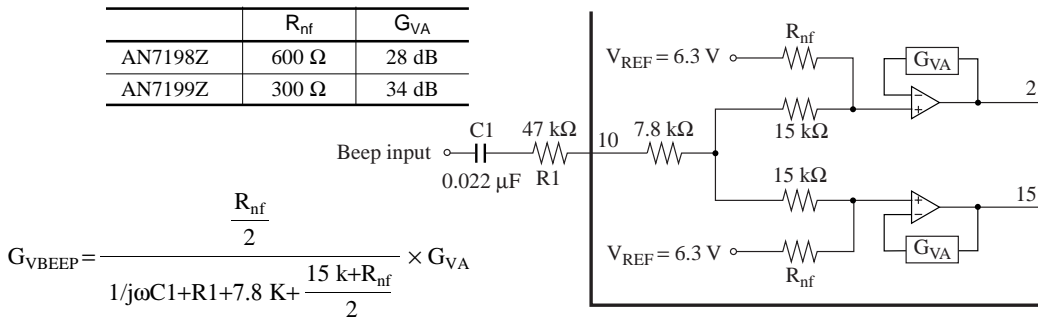

Figure 8

■ Technical Information (continued)

3. Application note (continued)

11) Two IC use

Figure 9 shows the application circuit example when two ICs are used:

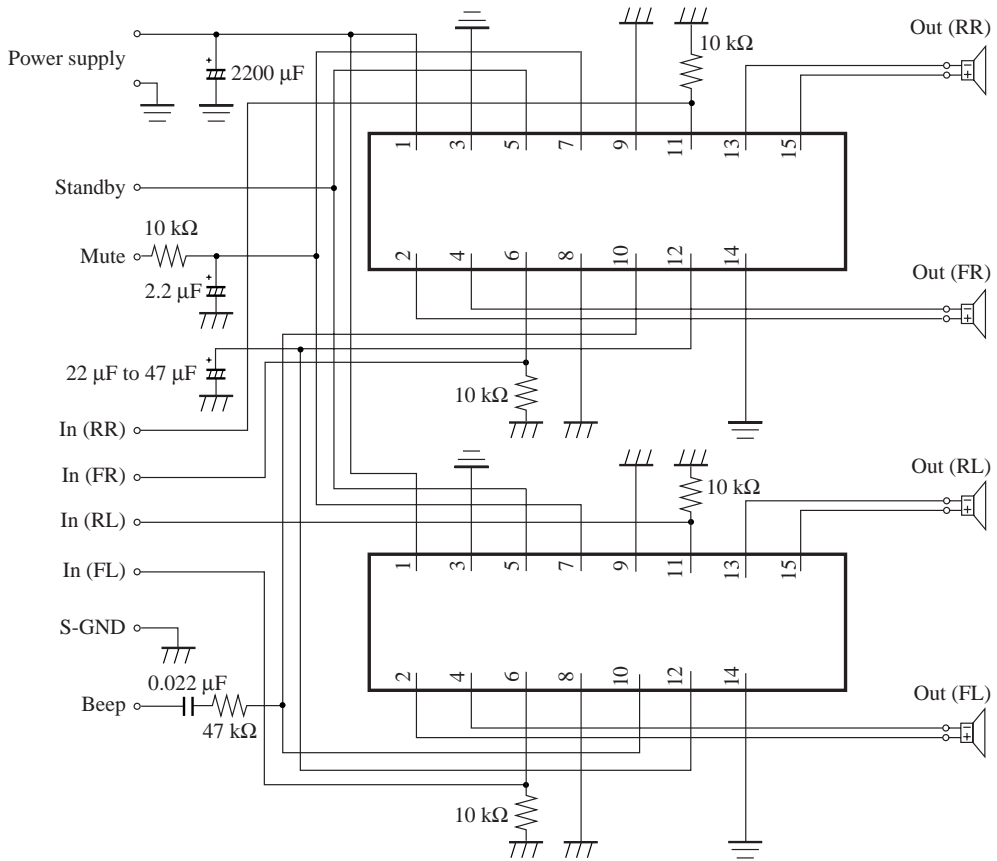

Figure 9

■ Technical Information (continued)

3. Application note (continued)

11) Two IC use (continued)

(1) Supply terminal

Short-circuit the terminals with each other and insert an electrolytic capacitor of approx. 2200 μF into the supply terminals. However, if sufficient characteristics of the ripple rejection can not be obtained, use an even larger capacitor or insert a 2200 μF capacitor into each IC.

The best sound quality can be obtained by inserting a 2200 μF capacitor near the terminal of each IC.

(2) Standby terminal (pin 5)

Even if the standby terminals are connected with each other, there is no abnormal operation. Connect with the microcomputer after connecting the standby pins with each other. At that time, the current flowing into the standby terminal is twice as large as the current which is described in 1) Standby function.

(3) Muting terminal (pin 7)

An abnormal operation does not occur even if the muting terminals are short-circuited with each other. The muting time constant changes when two ICs connection is made. If the CR constants are set at twice or 1/2 time respectively, the time constant value becomes as same as the value when one IC is used.

In terms of safety design, taking advantage of the fact that in mute-on, a large current is difficult to flow and it is difficult to cause the destruction, it is designed so that the mute terminal will become high when an abnormality such as short circuit to V_{CC} or short circuit to GND takes place. (To avoid the influence of IC in an abnormal state in using two ICs).

Do not connect a microcomputer directly to the mute terminal because the mute terminal voltage rises to approx. 12 V at that time.

(4) Beep sound input terminal (pin 10)

Even if the beep sound input terminals are short circuited each other, that does not result in an abnormal operation.

However, if there is a temperature difference between ICs, there may be a fluctuation of the output offset. In order to avoid such a phenomenon, connect the ICs with each other through a resistor (47 k Ω).

(5) Ripple filter terminal (pin 12)

Even if the ripple filter terminals are short circuited each other, that does not result in an abnormal operation.

However, if the standby of each IC is individually controlled, the short-circuiting is not allowed. Use the circuit after connecting a capacitor (33 μF) to each IC.

12) Precautions on misuse

(1) Erroneous connection in the case of short circuit to V_{CC} and short circuit to GND or load short-circuit

The AN7198Z/99Z have the breakdown voltage of 20 V or more when short circuit to V_{CC} or load short-circuit occur. However, there is a possibility of destruction, then smoke emission and ignition under a special condition. Avoid misuse and erroneous connection of the circuit.

(2) Power supply surge

The power supply surge breakdown voltage is evaluated by the test circuit shown in Figure 10 and the surge waveform as shown in Figure 11 is evaluated.

The withstanding capability against power supply surge is 80 V for the AN7198Z/99Z.

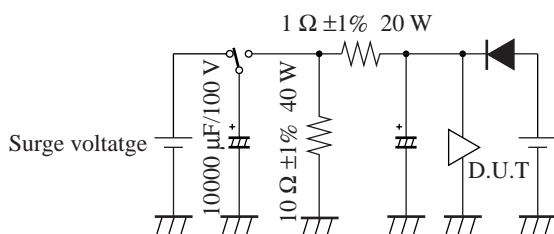

Figure 10. Power supply surge test circuit

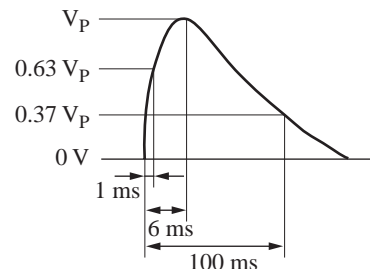

Figure 11. Surge waveform

■ Technical Information (continued)

3. Application note (continued)

12) Precautions on misuse (continued)

(1) Destruction mode for the AN7198Z/99Z

The AN7198Z/99Z are the power ICs with high breakdown withstanding voltage but it has been found that the destruction occurs under special conditions.

- GND-open short-circuit to ground.

Short-circuit the output terminal to the GND terminal of power supply when GND terminal of the IC is open, or a short-circuiting is made to GND when the GND terminal of the IC is over 0.7 V higher than the short-circuited output terminal.

At that time, if $V_{CC} = 16$ V or more and a voltage is also applied to STB terminal, then the destruction occurs.

- The plus and minus side output terminals are short-circuited to power supply at the same time.

If short-circuit to power supply occurs on both the plus and minus side output terminals at the same time with a short-circuit resistor which does not actuate the protection circuit, the power GND terminal current may exceed 10 A and the wire melts down since the current exceeds the capacity of Au wire.

- V_{CC} – GND reverse connection

Parasitic device is created everywhere and the circuit destruction takes place.

4. Countermeasure for shock noise of the AN7198Z

Points of shock noise prevention

Plus and minus output of the BTL amp. is not changed suddenly by STB-on/off and Mute-on/off.

1) Standby pin to off (pin 5 $V_{STB} = 5$ V \rightarrow 0 V) (Standby state \rightarrow Operating state)

(1) Ripple filter pin (pin 12) becomes on gradually (Charge up to V_{CC}) when $V_{STB} = 0$ V \rightarrow 5V.

Current source and reference voltage are on instantaneously.

(2) Output D range suppression circuit is incorporated which limits the dynamic range of output to 0 V $< V_{OUT} < V_{RF} - 3 V_{BE}$ when the ripple filter pin voltage is less than 6.8 V.

DC voltage change of input circuit causes steep DC voltage change of output pin and that generates shock noise. This steep DC voltage change can be suppressed by the above mentioned circuit.

Voltage of the mute pin (pin 7) makes high forcedly in the inside circuit.

(3) Input mute is on when the ripple filter pin voltage V_{RF} is less than 6.8 V.

This prevents the shock noise which is inputted from the pre-stage of power amp.

Also, mute is on in order to prevent the abnormal sound which is generated by clipping of waveform. (Output is clipped due to narrow D range at start up)

(4) DC voltage of output pin changes with 1/2 voltage of the ripple filter pin.

Steep changes of output pin voltage is suppressed by start up gradually of the ripple filter pin.

(5) Output waveform of each plus and minus output at power supply on changes as same by symmetric placement of inverting and non-inverting amplifier which consist of BTL amp.

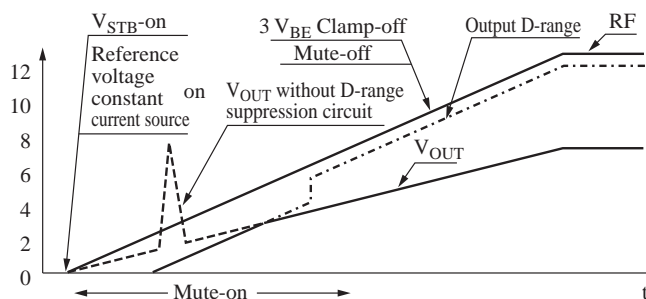

Image figure of output waveform, RF-pin waveform has exponential characteristics in actually.

■ Technical Information (continued)

4. Countermeasure for shock noise of the AN7198Z (continued)

2) Standby pin to off (pin 5 $V_{STB} = 5\text{ V} \rightarrow 0\text{ V}$) (Operating state \rightarrow Standby state)

(1) Ripple filter pin (pin 12) becomes off gradually (Discharge down to 0 V) when $V_{STB} = 5\text{ V} \rightarrow 0\text{ V}$.
Current source and reference voltage are on until $V_{RF} < 2\text{ V}_{BE}$.

(2) Output D range suppression circuit operates when the ripple filter pin voltage is less than 6.8 V.

The circuit limits to $0\text{ V} < V_{OUT} < V_{RF} - 3\text{ V}_{BE}$.

DC voltage change of input circuit causes steep DC voltage change of output pin and that generates shock noise same as at standby pin is on.

This steep DC voltage change can be suppressed by the above mentioned circuit.

Voltage of the mute pin (pin 7) makes high forcibly in the inside circuit.

(3) Input mute is on when ripple filter pin voltage V_{RF} is less than 6.8 V. This prevents the shock noise which is inputted from the pre-stage of power amp.

Also, mute is on in order to prevent the abnormal sound which is generated by clipping of waveform. (The purpose is same as the countermeasure of start up period.)

(4) DC voltage of output pin changes with 1/2 voltage of the ripple filter pin.

Steep changes of output pin voltage is suppressed by start up gradually of the ripple filter pin.

(5) Output waveform of each plus and minus output at power supply on changes as same by symmetric placement of inverting and non-inverting amplifier which consist of BTL amp.

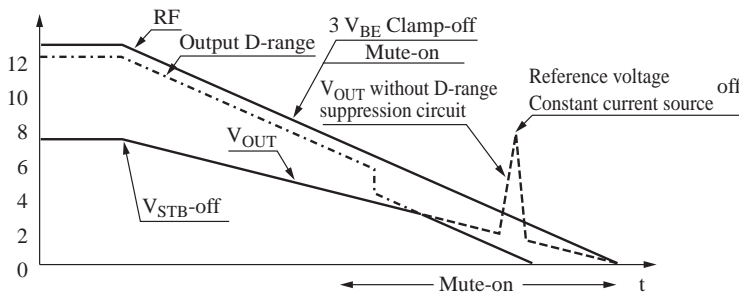

Image figure of output waveform, RF-pin waveform has exponential characteristics in actually.

3) Muting on/off (Pin7 low: Muting state, high: Operating state)

(1) AC mute circuit which mute the AC component only by the simple attenuator circuit is adopted.

Conventional system generates shock noise due to change steeply of output DC voltage by cutting of input DC voltage and muting of AC component.

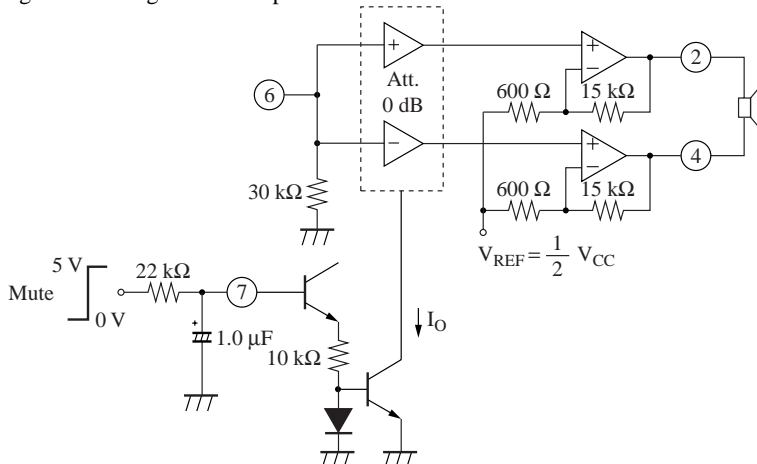

Figure 12

■ Technical Information (continued)

4. Countermeasure for shock noise of the AN7198Z (continued)

3) Muting on/off (Pin7 low: Muting state, high: Operating state) (continued)

- (2) Attack and recovery time of muting on/off is determined by the external CR time constant of pin 7.
- (3) There is afraid of shock noise when time constant is set to 10 ms or less.
(Since output DC voltage is changed approx. 50 mV by muting on/off.)

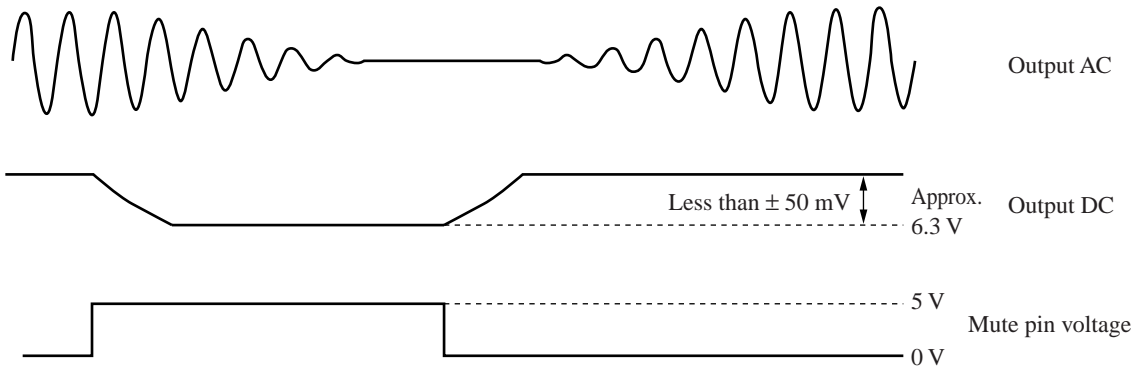
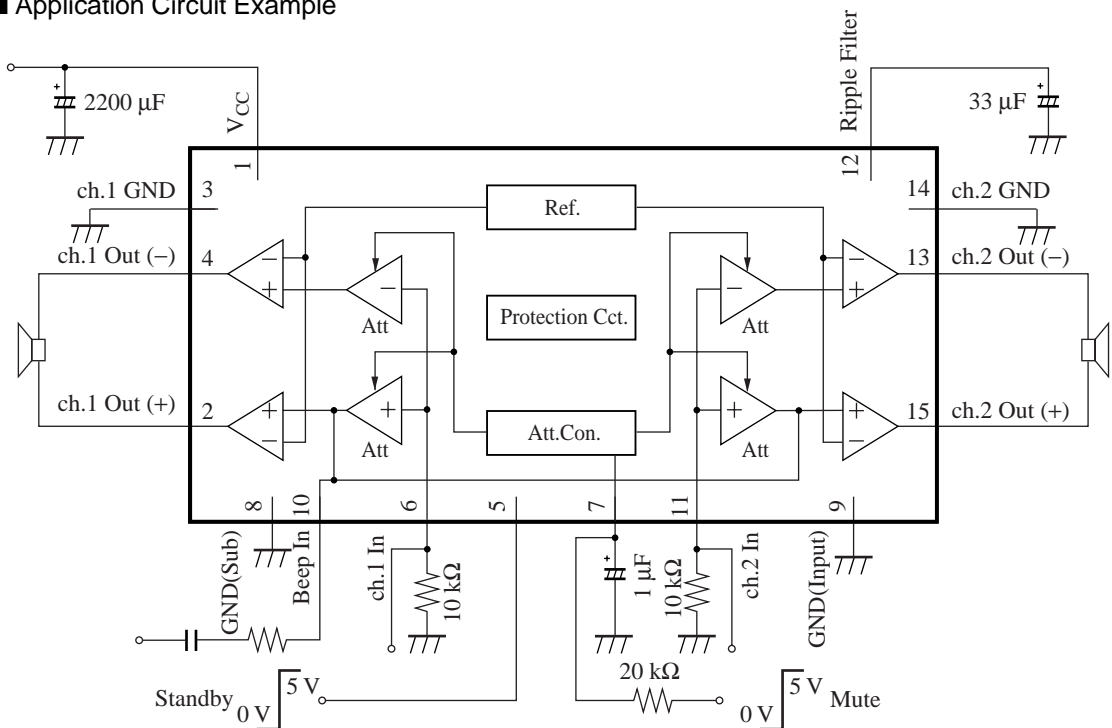

Figure 13

■ Application Circuit Example





LittleDiode supplies new, hard to find or obsolete electronic components and semiconductors all over the world.

With over two million different components listed you are sure to find the part you need.

Feel free to visit us today at our online store:

LittleDiode.com

Looking forward to providing you with the best possible service.