

AN7333S

4-Element Graphic Equalizer IC for Radio/Radio Cassette Recorder

■ Overview

The AN7333S is an integrated circuit for 4-element graphic equalizers most suitable for radio cassette / portable component stereo equipment.

2-channel 4-element graphic equalizer can be configured by applying frequency setting capacitors and variable resistors externally. Non-step adjustment of the boost and the cutting quantity is possible by variable resistors.

■ Features

- The resonance frequency can be freely set by optional selection of the capacitor capacitance.
- Low distortion rate: THD = 0.04% ($V_{CC} = 5\text{ V}$)
- Wide dynamic range: $V_O = 800\text{ mV[rms]}$ (at Boost THD = 1%)
- Low noise level: $V_{no} = 10\text{ }\mu\text{V}$ ($V_{CC} = 5\text{ V}$)

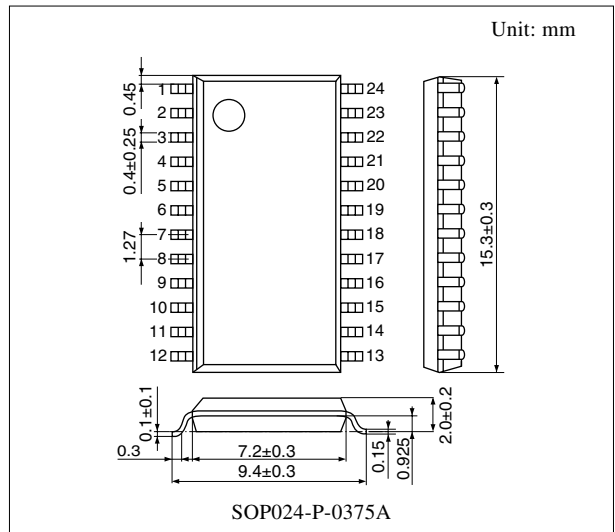

Note) The package of this product will be changed to lead-free type (SOP024-P-0375C). See the new package dimensions section later of this datasheet.

■ Block Diagram

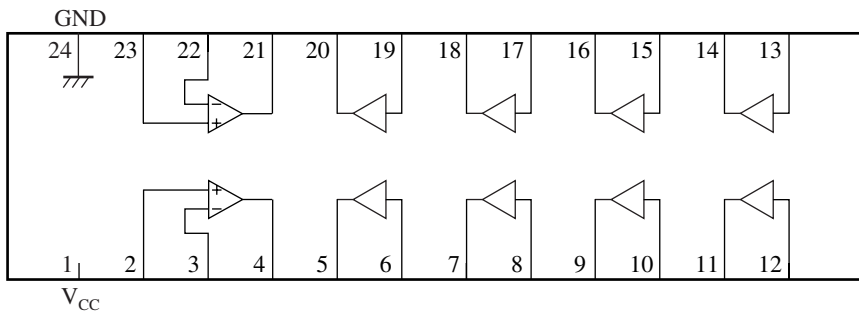

■ Pin Descriptions

Pin No.	Description	Pin No.	Description
1	Power supply	13	Input pin
2	Non inverting input	14	Negative feedback
3	Inverting input	15	Input pin
4	Output	16	Negative feedback
5	Negative feedback	17	Input pin
6	Input pin	18	Negative feedback
7	Negative feedback	19	Input pin
8	Input pin	20	Negative feedback
9	Negative feedback	21	Output
10	Input pin	22	Inverting input
11	Negative feedback	23	Non inverting input
12	Input pin	24	GND

■ Absolute Maximum Ratings

Parameter	Symbol	Rating	Unit
Supply voltage	V_{CC}	14.4	V
Supply current	I_{CC}	30	mA
Power dissipation	P_D	432	mW
Operating ambient temperature *1	T_{opr}	-20 to +75	°C
Storage temperature *1	T_{stg}	-55 to +125	°C

Note) *1: Except for the operating ambient temperature and storage temperature, all ratings are for $T_a = 25^\circ\text{C}$.

■ Recommended Operating Range

Parameter	Symbol	Range	Unit
Supply voltage	V_{CC1}, V_{CC2}	4 to 14	V

■ Electrical Characteristics at $V_{CC} = 5\text{ V}$, $T_a = 25^\circ\text{C}$

Parameter	Symbol	Conditions	Min	Typ	Max	Unit
Total circuit current	I_{tot}	$V_{IN} = 0\text{ mV}$	—	7.5	—	mA
Voltage gain	G_V	$f = 1\text{ kHz}$, $V_O = -10\text{ dBV}$	—	-1.5	—	dB
Boost quantity	Boost	$V_O = -20\text{ dBV}$ is set to 0 dBV	—	9.5	—	dB
Cut quantity	Cut	$V_O = -20\text{ dBV}$ is set to 0 dBV	—	-9.5	—	dB
Total harmonic distortion	THD	$f = 1\text{ kHz}$, $V_O = -20\text{ dBV}$	—	0.04	—	%
Output noise voltage	V_{no}	$R_g = 0\ \Omega$, Total Flat, DIN/AUDIO	—	10	—	μV
Crosstalk	CT	$f = 1\text{ kHz}$, $R_g = 0\ \Omega$, Total Flat, $V_O = -20\text{ dBV}$	—	12	—	μV

■ Terminal Equivalent Circuits

Pin No.	Equivalent circuit	Description	Pin voltage (V)
1	—	Power supply: Supply pin	5
2 23		Non inverting input: Output buffer circuit non-inverting input pin	$\frac{1}{2} V_{CC}$
3 22		Inverting input: Output buffer circuit inverting input pin	Center electric potential
4 21		Output: Output buffer output pin	Center electric potential
5, 7, 9, 11, 14, 16, 18, 20		Negative feedback: Resonance circuit negative feedback pin	Center electric potential
6, 8, 10, 12, 13, 15, 17, 19		Input pin: Resonance circuit input pin	Center electric potential
24	—	GND pin:	0

■ Main Characteristics

THD — V_{CC}

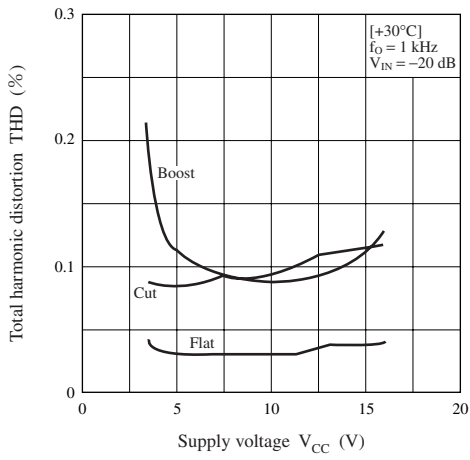

THD — V_O

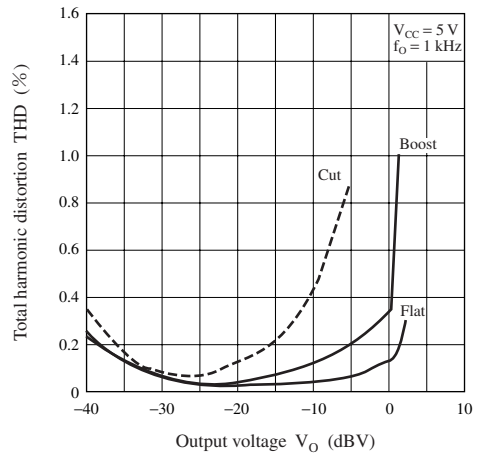

Frequency characteristics

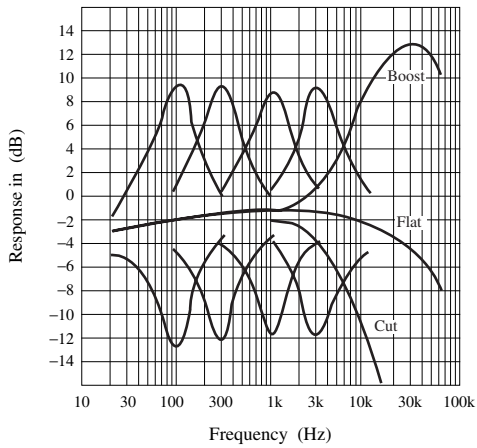

■ Application Circuit Example

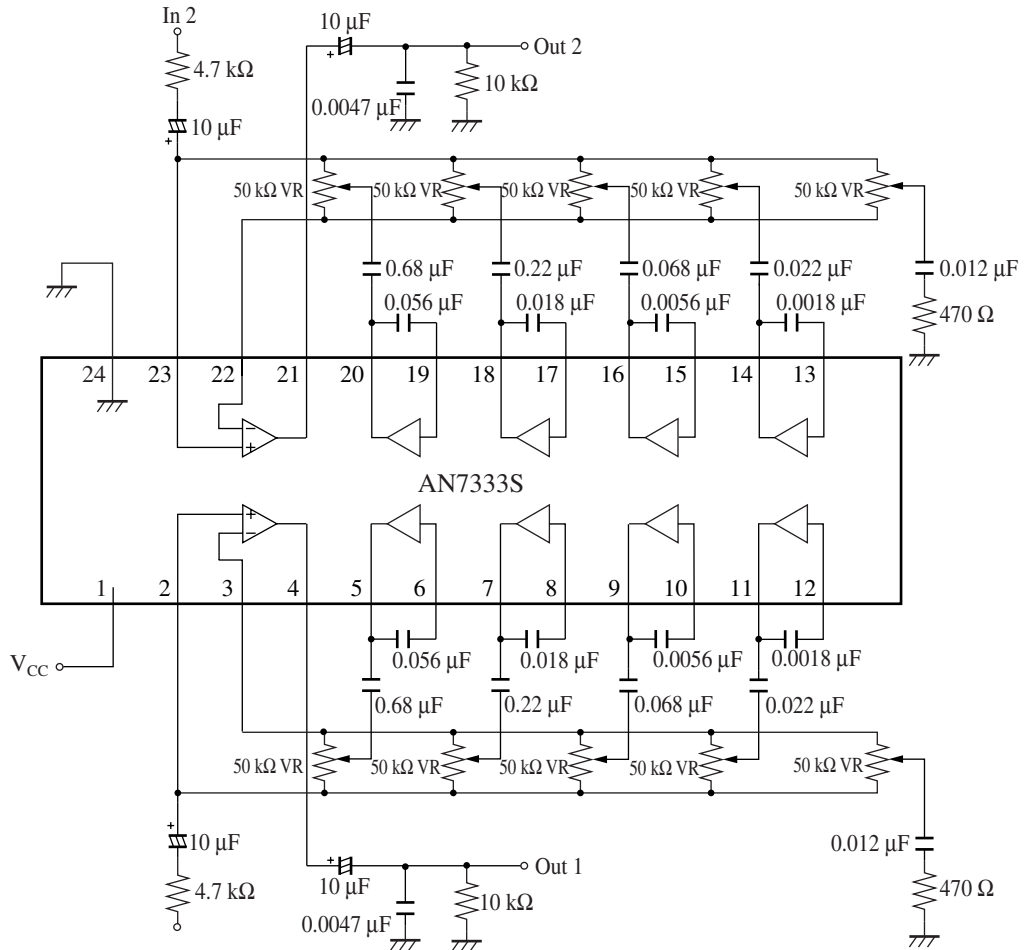

Note) VR is B or G type.

• Resonant frequency fo

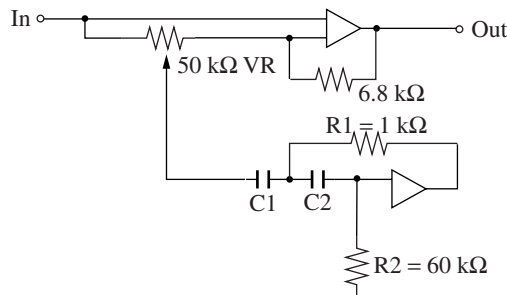

$$f_o = \frac{1}{2\pi\sqrt{C1 \times C2 \times R1 \times R2}}$$

(Internal resistance: R1 = 1 kΩ, R2 = 60 kΩ)

- * Internal resistance: As R1 and R2 of internal resistors are common in each oscillation circuit, fo can be adjustable from an external capacitor.
- * Gain can be adjusted by the 50 kΩ variable resistor.

■ New Package Dimensions (Unit: mm)

- SOP024-P-0375C (Lead-free package)

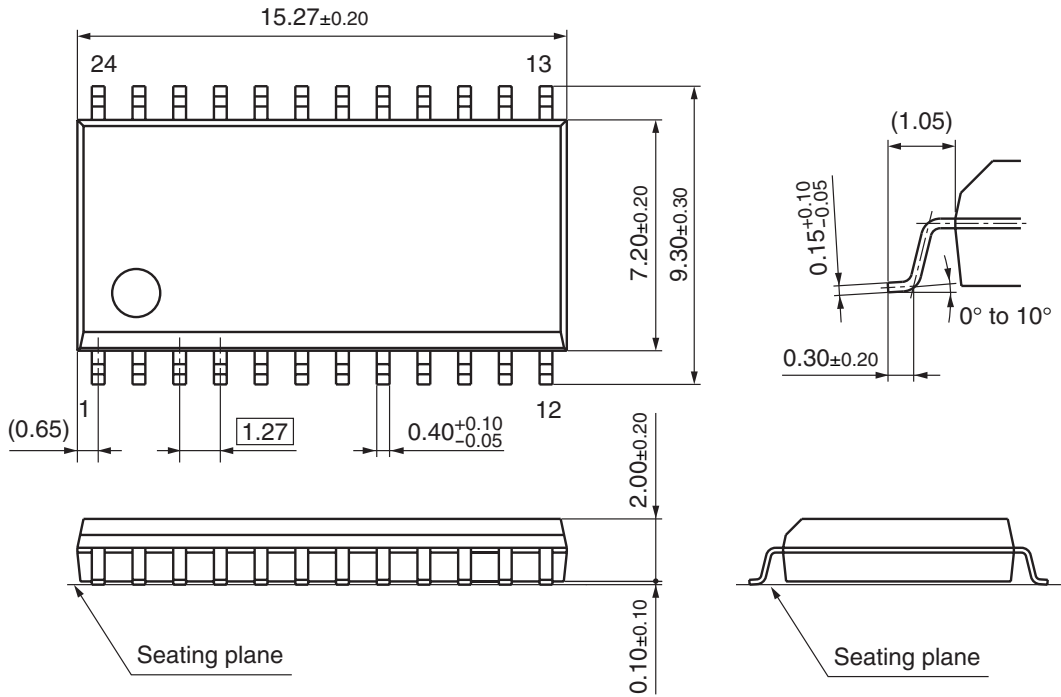

Request for your special attention and precautions in using the technical information and semiconductors described in this material

- (1) An export permit needs to be obtained from the competent authorities of the Japanese Government if any of the products or technologies described in this material and controlled under the "Foreign Exchange and Foreign Trade Law" is to be exported or taken out of Japan.
- (2) The technical information described in this material is limited to showing representative characteristics and applied circuit examples of the products. It does not constitute the warranting of industrial property, the granting of relative rights, or the granting of any license.
- (3) The products described in this material are intended to be used for standard applications or general electronic equipment (such as office equipment, communications equipment, measuring instruments and household appliances).
Consult our sales staff in advance for information on the following applications:
 - Special applications (such as for airplanes, aerospace, automobiles, traffic control equipment, combustion equipment, life support systems and safety devices) in which exceptional quality and reliability are required, or if the failure or malfunction of the products may directly jeopardize life or harm the human body.
 - Any applications other than the standard applications intended.
- (4) The products and product specifications described in this material are subject to change without notice for reasons of modification and/or improvement. At the final stage of your design, purchasing, or use of the products, therefore, ask for the most up-to-date Product Standards in advance to make sure that the latest specifications satisfy your requirements.
- (5) When designing your equipment, comply with the guaranteed values, in particular those of maximum rating, the range of operating power supply voltage and heat radiation characteristics. Otherwise, we will not be liable for any defect which may arise later in your equipment.
Even when the products are used within the guaranteed values, redundant design is recommended, so that such equipment may not violate relevant laws or regulations because of the function of our products.
- (6) When using products for which dry packing is required, observe the conditions (including shelf life and after-unpacking standby time) agreed upon when specification sheets are individually exchanged.
- (7) No part of this material may be reprinted or reproduced by any means without written permission from our company.

Please read the following notes before using the datasheets

- A. These materials are intended as a reference to assist customers with the selection of Panasonic semiconductor products best suited to their applications.
Due to modification or other reasons, any information contained in this material, such as available product types, technical data, and so on, is subject to change without notice.
Customers are advised to contact our semiconductor sales office and obtain the latest information before starting precise technical research and/or purchasing activities.
- B. Panasonic is endeavoring to continually improve the quality and reliability of these materials but there is always the possibility that further rectifications will be required in the future. Therefore, Panasonic will not assume any liability for any damages arising from any errors etc. that may appear in this material.
- C. These materials are solely intended for a customer's individual use.
Therefore, without the prior written approval of Panasonic, any other use such as reproducing, selling, or distributing this material to a third party, via the Internet or in any other way, is prohibited.



LittleDiode supplies new, hard to find or obsolete electronic components and semiconductors all over the world.

With over two million different components listed you are sure to find the part you need.

Feel free to visit us today at our online store:

LittleDiode.com

Looking forward to providing you with the best possible service.