

■ Block Diagram

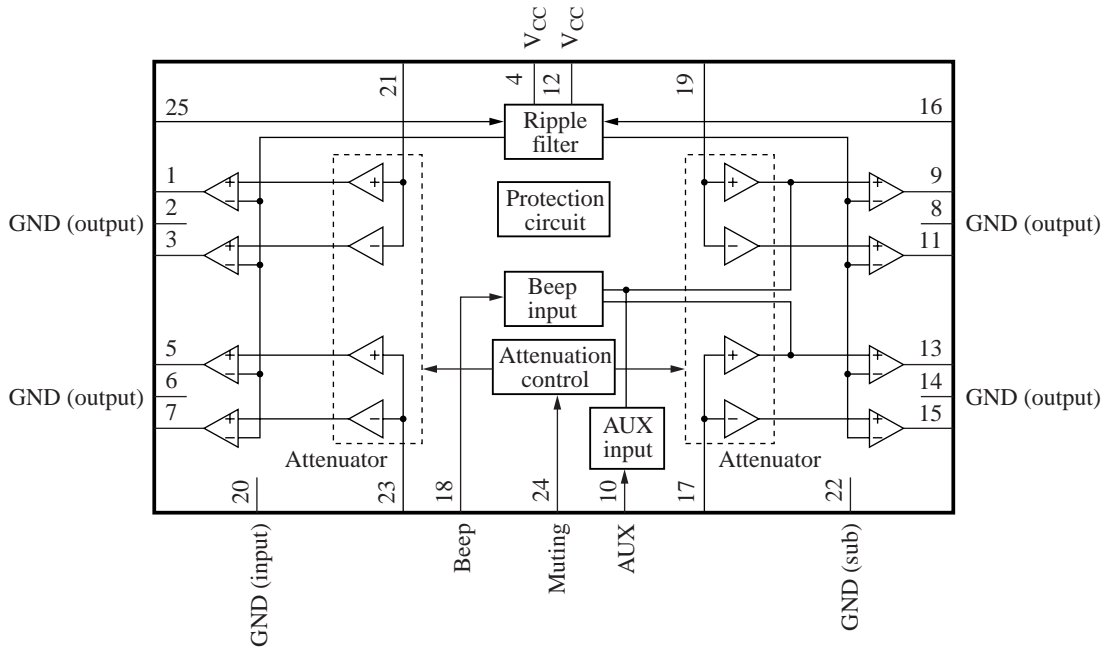

■ Pin Descriptions

Pin No.	Description	Pin No.	Description
1	Ch.4 + output	14	GND (ch.1 output)
2	GND (ch.4 output)	15	Ch.1 – output
3	Ch.4 – output	16	Standby
4	Supply voltage V_{CC}	17	Ch.1 input
5	Ch.3 + output	18	Beep input
6	GND (ch.3 output)	19	Ch.2 input
7	Ch.3 – output	20	GND (input)
8	GND (ch.3 output)	21	Ch.4 input
9	Ch.2 + output	22	GND (printed circuit board)
10	AUX input	23	Ch.3 input
11	Ch.2 – output	24	Muting
12	Supply voltage V_{CC}	25	Ripple filter
13	Ch.1 + output		

Note) It is not necessary to connect capacitor and resistor for stopping the oscillation at the output terminals.
Use them after check if necessary for noise countermeasure.

■ Absolute Maximum Ratings

Parameter	Symbol	Rating	Unit
Supply voltage *2	V_{CC}	25	V
Peak supply voltage *3	V_{surge}	65	V
Supply current	I_{CC}	12	A
Power dissipation *4	P_D	59	W
Operating ambient temperature *1	T_{opr}	-30 to +85	°C
Storage temperature *1	T_{stg}	-55 to +150	°C

Note) *1 : $T_a = 25^\circ\text{C}$ except operating ambient temperature and storage temperature.

*2 : Without signal

*3 : Time = 0.2 s

*4 : Power dissipation at $T_a = 85^\circ\text{C}$

■ Recommended Operating Range

Parameter	Symbol	Range	Unit
Supply voltage	V_{CC}	8.0 to 18.0	V

■ Electrical Characteristics at $V_{CC} = 13.2\text{ V}$, $f = 1\text{ kHz}$, $T_a = 25^\circ\text{C}$

Parameter	Symbol	Conditions	Min	Typ	Max	Unit
Quiescent current	I_{CQ}	$R_g = 10\text{ k}\Omega$, $R_L = 4\ \Omega$	—	300	450	mA
Standby current	I_{STB}	$R_g = 10\text{ k}\Omega$, $R_L = 4\ \Omega$	—	1	10	μA
Output noise voltage *1	V_{NO}	$R_g = 10\text{ k}\Omega$, $R_L = 4\ \Omega$	—	0.25	0.5	mV[rms]
Voltage gain	G_V	$V_{IN} = 20\text{ mV}$, $R_L = 4\ \Omega$	38	40	42	dB
Total harmonic distortion 1	THD1	$V_{IN} = 20\text{ mV}$, $R_L = 4\ \Omega$	—	0.05	0.2	%
Maximum output power	P_O	THD = 10%, $R_L = 4\ \Omega$	16	19.5	—	W
Ripple rejection *1	RR	$R_L = 4\ \Omega$, $R_g = 10\text{ k}\Omega$, $V_R = 1\text{ V[rms]}$, $f_R = 1\text{ kHz}$	55	65	—	dB
Channel balance	CB	$V_{IN} = 20\text{ mV}$, $R_L = 4\ \Omega$	—	0	1	dB
Cross-talk	CT	$V_{IN} = 20\text{ mV}$, $R_L = 4\ \Omega$, $R_g = 10\text{ k}\Omega$	60	70	—	dB
Output offset voltage	V_{OFF}	$R_g = 10\text{ k}\Omega$, $R_L = 4\ \Omega$	-300	0	300	mV
Muting effect *1	MT	$V_{IN} = 20\text{ mV}$, $R_L = 4\ \Omega$	70	80	—	dB
Input impedance	Z_I	$V_{IN} = \pm 0.3\text{ V}_{DC}$	24	30	36	k Ω
Shock noise *2	V_S	$R_L = 4\ \Omega$, $R_g = 10\text{ k}\Omega$, $V_{MUTE} = 5\text{ V}$, $V_{STB} = \text{on/off}$, 50 Hz HPF	-100	0	100	mV[p-0]

Note) *1 : Measurement using a bandwidth 15 Hz to 30 kHz (12 dB/OCT) filter.

*2 : Change over the standby terminal at the time shown in the right.

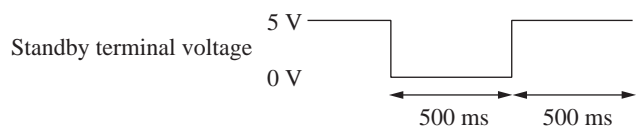

■ Electrical Characteristics at $V_{CC} = 13.2\text{ V}$, $f = 1\text{ kHz}$, $T_a = 25^\circ\text{C}$ (continued)

Parameter	Symbol	Conditions	Min	Typ	Max	Unit
Total harmonic distortion 2	THD2	$V_{IN} = 10\text{ mV}$, $f_{IN} = 20\text{ kHz}$, $R_g = 10\ \Omega$, $R_L = \infty$	—	0.1	0.5	%
Mute-on threshold voltage	MT_{ON}	$V_{IN} = 20\text{ mV}$, $R_L = 4\ \Omega$	4	—	—	V
Mute-off threshold voltage	MT_{OFF}	$V_{IN} = 20\text{ mV}$, $R_L = 4\ \Omega$	—	—	0.8	V
Cutoff frequency	f_C	$V_{IN} = 20\text{ mV}$, $R_L = 4\ \Omega$, $G_V = -1\text{ dB}$ (0 dB: 1 kHz)	20	40	—	kHz

• Design reference data

Note) The characteristic values below are theoretical values for designing and not guaranteed.

Parameter	Symbol	Conditions	Min	Typ	Max	Unit
Maximum output power	P_{Omax}	Max. power, $R_L = 4\ \Omega$	—	28	—	W
	P_{O2}	$V_{CC} = 14.4\text{ V}$, THD = 10%, $R_L = 4\ \Omega$	—	21	—	
	P_{Omax2}	$V_{CC} = 14.4\text{ V}$, max. power, $R_L = 4\ \Omega$	—	34	—	
Power band width	f_{PL}	$V_{CC} = 14.4\text{ V}$, THD = 1%, $R_L = 4\ \Omega$, $PoL = -3\text{ dB}$ (1 kHz: 0 dB)	—	10	—	Hz
	f_{PH}	$V_{CC} = 14.4\text{ V}$, THD = 1%, $R_L = 4\ \Omega$, $PoH = -3\text{ dB}$ (1 kHz: 0 dB)	—	18	—	kHz
STB threshold voltage	V_{STB1}	$R_g = 10\text{ k}\Omega$, $R_L = 4\ \Omega$, STB \rightarrow ACT	—	2.2	—	V
	V_{STB2}	$R_g = 10\text{ k}\Omega$, $R_L = 4\ \Omega$, ACT \rightarrow STB	—	1.5	—	

■ Usage Notes

1. Always attach an outside heat sink to use the AN7555NZ. In addition, the outside heat sink must be fastened onto a chassis for use.
2. Connect the radiation fin to the GND potential.
3. Prevent short circuit to V_{CC} and short circuit to GND, and load short-circuit although the protection circuits for short circuit to V_{CC} and ASO are built-in.
4. The thermal protection circuit gets actuated when $T_j = \text{approx. } 150^\circ\text{C}$, but it is automatically reset when the chip temperature drops below the above set level.
5. The overvoltage protection circuit starts the protection operation at $V_{CC} = \text{approx. } 20\text{ V}$.
6. Take into consideration the heat radiation design particularly when V_{CC} is set high.
7. When the beep sound function is not used, connect to GND the beep sound input pin.
8. Don't down below -0.3 V for the beep sound input pin.
9. When the AUX function is not used, open the AUX input pin.
10. Connect to signal GND of pre-stage amplifier only for the signal source ground.

• There are the possibility of breakdown for the following conditions.

1. Reverse connection of the power supply pin and the GND pin.
2. Connection of the power supply between output pins at open condition of the power supply pin and the GND pin.
3. Short circuit to GND of output pin when the GND pin is open.
4. Short circuit to GND of above the three output pins at the same time with a shorting resistor which does not operate the protection circuit.
5. Short circuit to GND of above the plus and minus output pins at the same time with a shorting resistor which does not operate the protection circuit.
6. Short circuit to ground with shorting the RF pin and the output pin.

■ Technical Information

- $P_D - T_a$ curves of HZIP025-P-0980

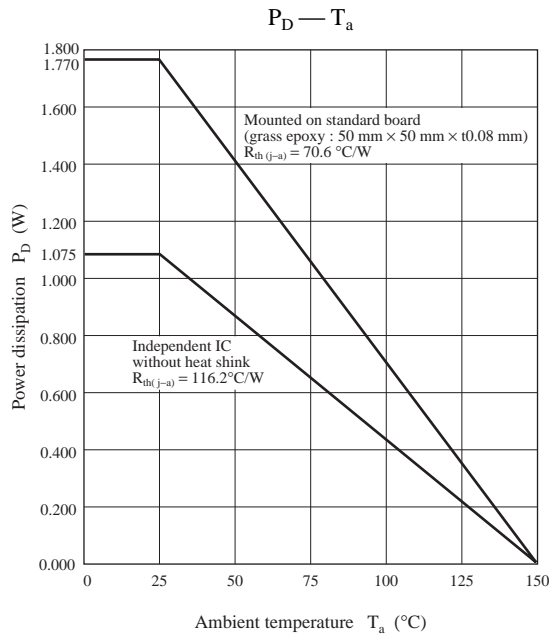

■ Application Circuit Example

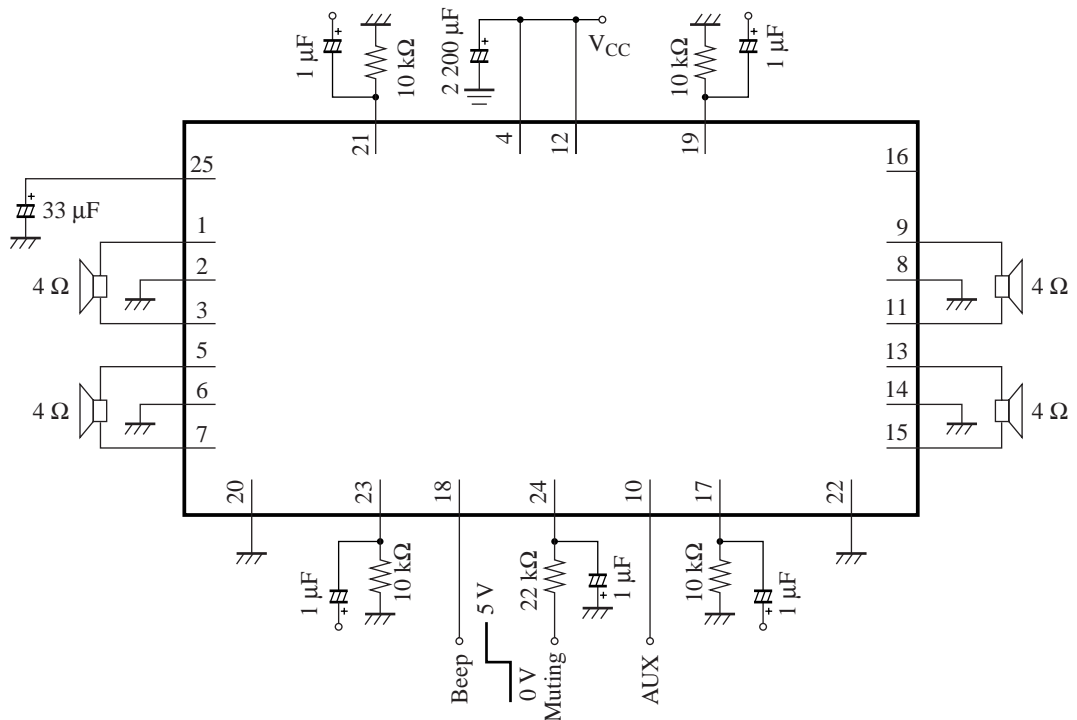



LittleDiode supplies new, hard to find or obsolete electronic components and semiconductors all over the world.

With over two million different components listed you are sure to find the part you need.

Feel free to visit us today at our online store:

LittleDiode.com

Looking forward to providing you with the best possible service.