

AN8060

Negative output, low dropout voltage (-4V) regulator with reset pin

Overview

The AN8060 is the low dropout voltage regulator having the function of resetting output voltage. With a built-in comparator to sense a reduced voltage, it is suitable for battery operating equipment.

Features

- With reset function: Bias current at resetting $5\mu\text{A}$
- Small input-output voltage difference: $I_O = 30\text{mA}$, 0.2V
- Low supply voltage sensing comparator built-in

Block Diagram

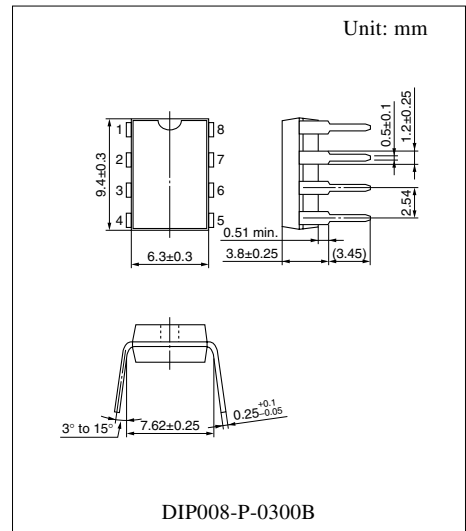
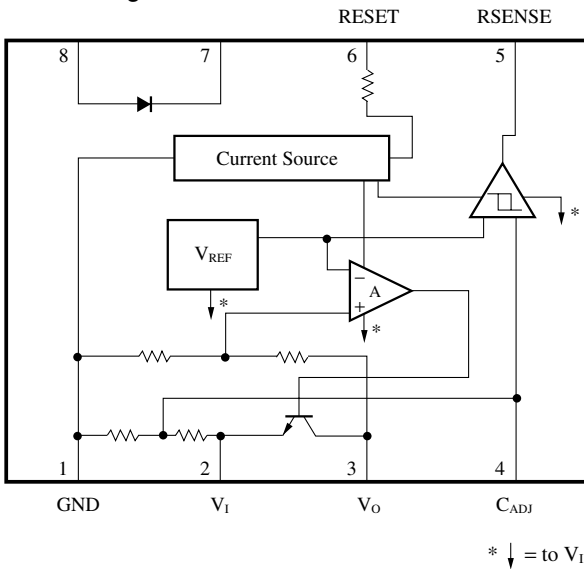

Pin Descriptions

Pin No.	Symbol	Pin name
1	GND	GND
2	V_I	Input voltage
3	V_O	Output voltage
4	C_{ADJ}	Low supply voltage sensing adj.
5	RSENSE	Low supply voltage sensing output
6	RESET	Reset pin
7	D_{IC}	Diode pin (Cathode)
8	D_{IA}	Diode pin (Anode)

■ Absolute Maximum Ratings at $T_a = 25^\circ\text{C}$

Parameter	Symbol	Rating	Unit
Supply voltage	V_{CC}	-12 to +0.3	V
Supply current	I_{CC}	—	mA
Power dissipation	P_D	500	mW
Operating ambient temperature	T_{opr}	-20 to +75	$^\circ\text{C}$
Storage temperature	T_{stg}	-55 to +150	$^\circ\text{C}$

■ Electrical Characteristics at $T_a = 25^\circ\text{C}$

Parameter	Symbol	Conditions	Min	Typ	Max	Unit
Bias current at reset	I_{RB}	$V_{RESET} = 0\text{V}$, $V_I = -6\text{V}$	—	—	5	μA
Bias current at no load	I_{UB}	$V_I = -6\text{V}$	—	2.5	6	mA
Output voltage	V_O	$V_I = -6\text{V}$, $I_O = 10\text{mA}$	-4.08	-3.92	-3.76	V
Output voltage tolerance	V_T	$V_I = -4.4$ to -8V , $I_O = 1$ to 30mA	-4.06	—	-3.66	V
Line regulation	V_{IS}	$V_I = -4.4$ to -7.4V , $I_O = 10\text{mA}$	—	3.6	60	mV
Load regulation	V_{LS}	$V_I = -6\text{V}$, $I_O = 1$ to 30mA	—	8	60	mV
Input/output voltage difference	V_{IOS}	$V_I = -3.8\text{V}$, $I_O = 30\text{mA}$	—	0.1	0.2	V
Reset pin input current "H"	I_{RICH}	$V_I = -6\text{V}$, $V_{RESET} = 0\text{V}$	-1	—	—	μA
Reset pin input current "L"	I_{RICL}	$V_I = -6\text{V}$, $V_{RESET} = -6\text{V}$	-200	—	—	μA
Low supply voltage sensing level	V_{RDL}	$I_O = 10\text{mA}$	-4.55	-4.3	-4.05	V
Output voltage at reset	V_{RO}	$V_{RESET} = 0\text{V}$, $V_I = -6\text{V}$	-0.1	—	—	V
Comparator output current	I_{CO}	$V_I = -4\text{V}$, $V_{RESENSE} = -3.6\text{V}$	1	—	—	mA

■ Main Characteristics

