

AN8081NK

2ch. Switching Power Supply Control

Overview

The AN8081NK is an IC which incorporates the basic circuit required for the switching power supply into two channels. It realizes the complete synchronous operation with the same oscillation output waveform.

One of two channels uses the output fixed to 5V.

Features

- Short-circuit protection function incorporated
- Wide operating supply voltage range (3.6 to 35V)
- Small consumption current (up to 3mA during operation)
- Built-in circuit preventing the malfunction under low input voltage

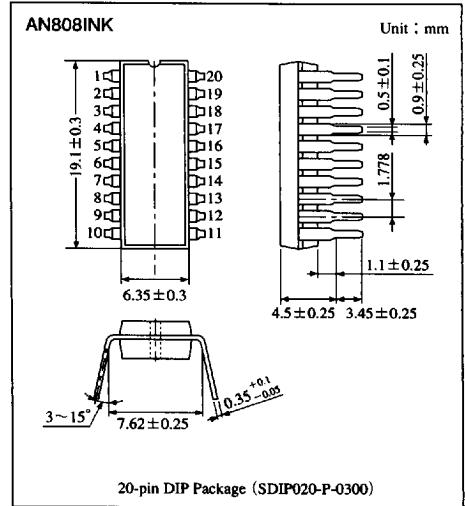

Block Diagram

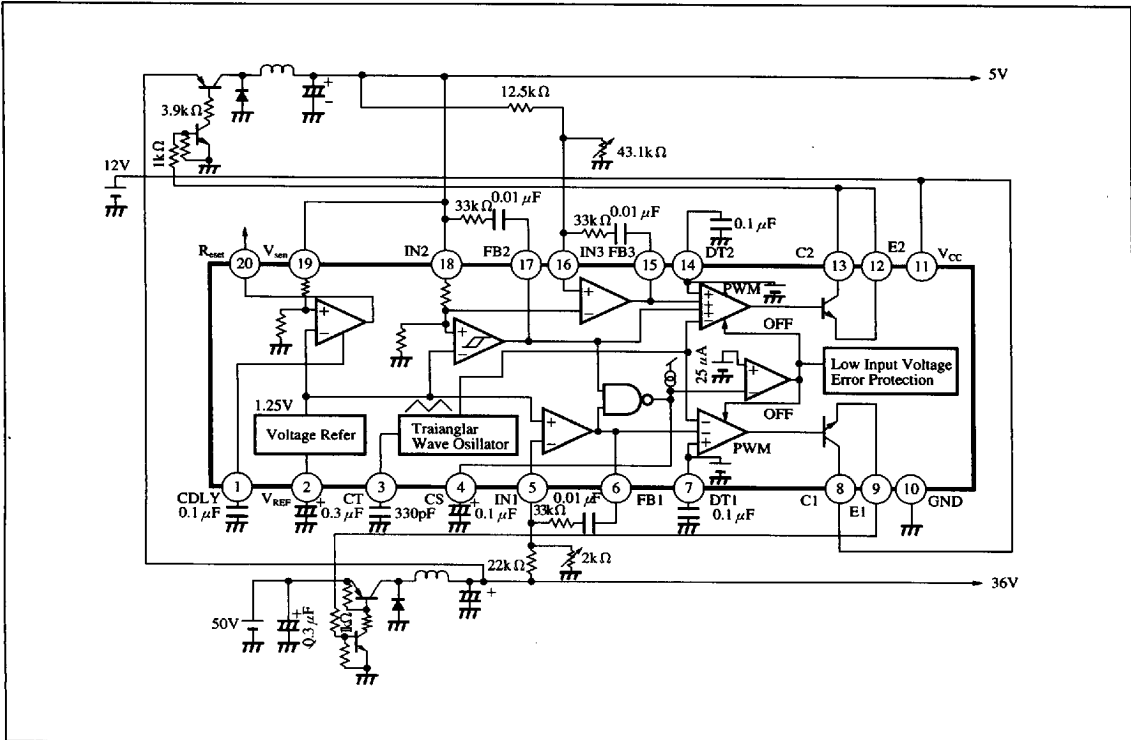

Voltage
Regu-
lators

6932852 0012768 740

Panasonic

■ Absolute Maximum Ratings (Ta=25°C)

Parameter	Symbol	Rating	Unit
Supply voltage	V _{CC}	35	V
Power dissipation	P _D		mW
Operating ambient temperature	T _{opr}	-30 to +85	°C
Storage temperature	T _{stg}	-55 to +150	°C

■ Recommended Operating Range (Ta=25°C)

Parameter	Symbol	Range	Unit
Operating supply voltage	V _{CC}	3.6 to 34	V

■ Electrical Characteristics (Ta=25°C)

Parameter	Symbol	Condition	min	typ	max	Unit
Supply current	I _{CC}		—	4	7	mA

Reference Voltage Block

Output voltage	V _{REF}	I _{OR} = -1mA	2.37	2.5	2.62	V
Input stability	Line	V _{CC} = 3.6 to 34V	—	10	100	mV
Load stability	LOAD	I _{OR} = 0 to -1mA	—	1	100	mV

Circuit Preventing Malfunction Under Low Input

Threshold voltage	V _{CC(on)}		2.8	3	3.2	V
Threshold voltage	V _{CC(off)}		2.4	2.6	2.8	V
Hysteresis width	ΔV _{CC(th)}		300	400	500	mV

Short-Circuit Protection Circuit Block

Input threshold voltage	V _{TH}		1.17	1.27	1.37	V
Charging current	I _{CS}		-35	-25	-15	μA

Triangular Oscillation Block

Oscillation frequency	f _{OSC}	CT = 330pF	90	115	140	kHz
Triangular wave peak value	V _{CTH}	CT = 330pF	0.85	0.9	0.95	V
Triangular wave bottom value	V _{CTL}	CT = 330pF	0.25	0.3	0.35	V

Dead Time Control Block

Bias voltage	V _{DT1}		0.82	0.86	0.9	V
Bias voltage	V _{DT2}		0.82	0.86	0.9	V

Error Amp.1

Input threshold voltage	V _{TH1}		0.72	0.75	0.78	V
Output voltage H	V _{OH1}	V _{IN1} = 0V, I _{FB1} = -80μA	2	—	—	V
Output voltage L	V _{OL1}	V _{IN1} = 2V, I _{FB1} = 500μA	—	—	0.2	V

Error Amp.2

V _{SIN} threshold voltage	V _{SIN(th)}		4.85	5.05	5.25	V
Input threshold voltage	V _{TH2}		0.72	0.75	0.78	V
Output voltage H	V _{OH2}	V _{SIN} = 4.5V, I _{FB2} = -80μA	2.0	—	—	V
Output voltage L	V _{OL2}	V _{SIN} = 5.5V, I _{FB2} = 500μA	—	—	0.2	V

Error Amp.3

Input threshold voltage	V _{TH3}	V _{SIN} = 5V	0.72	0.75	0.78	V
Output voltage H	V _{OH3}	V _{SIN} = 5V, V _{IN3} = 0V, I _{FB} = -80μA	2	—	—	V
Output voltage L	V _{OL3}	V _{SIN} = 5V, V _{IN3} = 2V, I _{FB} = 500μA	—	—	0.2	V

■ 6932852 0012769 687 ■

Panasonic

■ Electrical Characteristics (cont.) ($T_a=25^{\circ}\text{C}$)

Parameter	Symbol	Condition	min	typ	max	Unit
Output Block						
Output voltage	V_{OHC}	$V_{\text{IN}}=0\text{V}, C_{\text{T}}=1\text{V}, V_{\text{E}}=0\text{V}, I_{\text{C}}=75\text{mA}$	—	—	0.75	V
Output current	I_{OC}	$V_{\text{IN}}=0\text{V}, C_{\text{T}}=0\text{V}, V_{\text{E}}=0\text{V}, V_{\text{C}}=35\text{V}$	—	—	1	μA
Output maximum duty ratio	Γ_{max}	$C_{\text{T}}=330\text{pF}$	85	90	—	%
Reset Output Block						
Threshold voltage	V_{SEN}		4.1	4.3	4.5	V
Hysteresis width	ΔV_{SEN}	$V_{\text{SEN}}=4\text{V}, I_{\text{RESET}}=1\text{mA}$	100	150	200	mV
Output voltage	V_{RESET}	$V_{\text{SEN}}=4\text{V}, V_{\text{SIN}}=5\text{V}, I_{\text{RESET}}=1\text{mA}$	—	—	0.4	V

■ Application Circuit

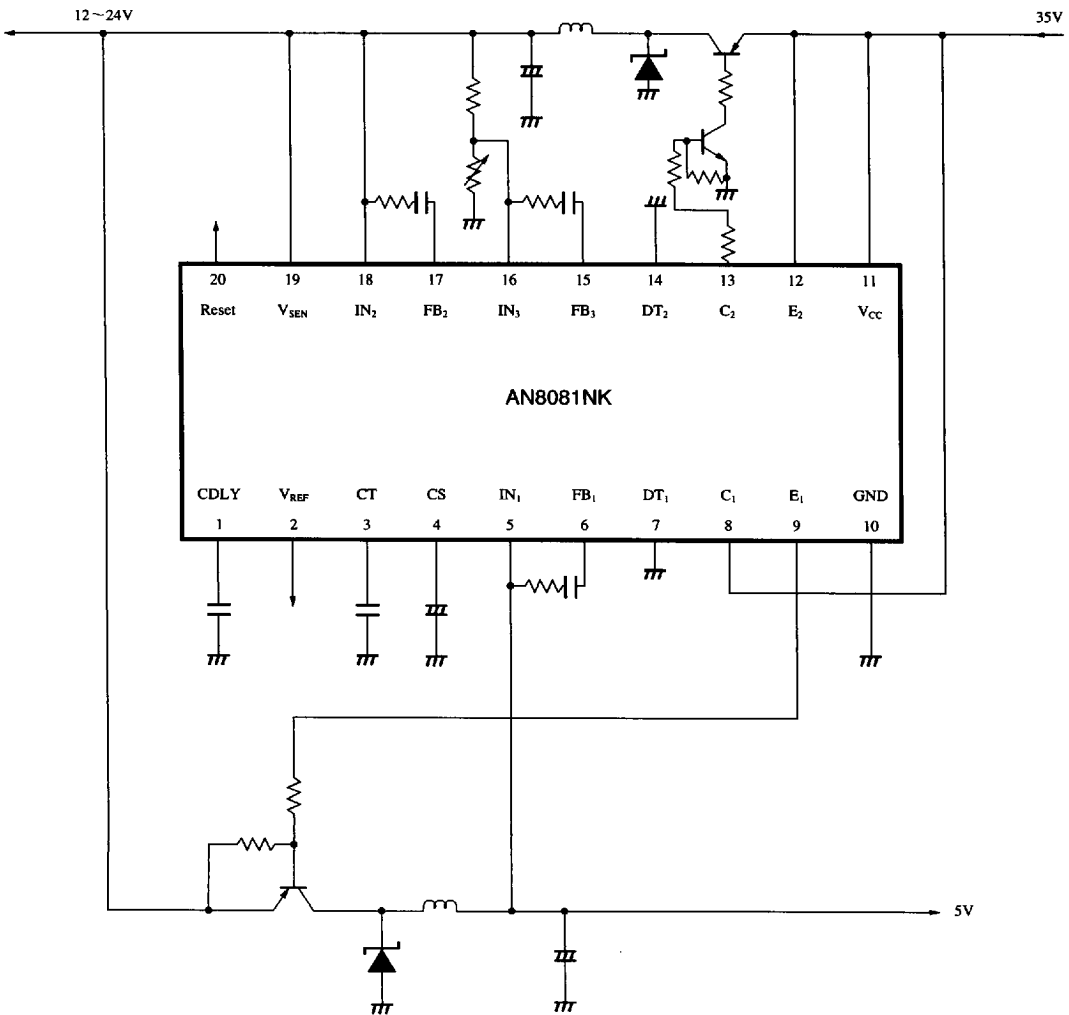

Voltage Regulators

6932852 0012770 3T9

Panasonic

■ Timing Chart

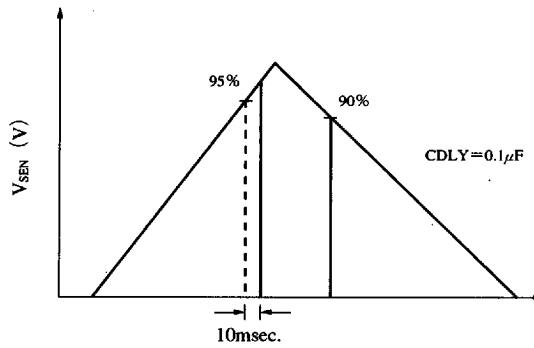

■ Pin Descriptions

Pin No.	Symbol	Description	Pin No.	Symbol	Description
1	CDLY	Capacitor for reset delay	11	V_{CC}	Power supply
2	V_{REF}	Reference voltage	12	E_2	Emitter output 2
3	CT	Capacitor for oscillation	13	C_2	Collector output 2
4	CS	Short-circuit protection input	14	DT_2	Dead time control 2
5	IN_1	Error amp. input 1	15	FB_3	Error amp. output 3
6	FB_1	Error amp. output 1	16	IN_3	Error amp. input 3
7	DT_1	Dead time control 1	17	FB_2	Error amp. output 2
8	C_1	Collector output 1	18	IN_2	Error amp. input 2
9	E_1	Emitter output 1	19	V_{SEN}	Reset input
10	GND	GND	20	Reset	Reset output

■ 6932852 0012771 235 ■

Panasonic