

DATA SHEET

Part No.	AN80T54
Package Code No.	HSIP012-P-0000A

Maintenance/Discontinued includes following lifecycle stage.
planned maintenance type
maintenance type
planned discontinued type
discontinued type
Please visit following URL about latest information.
<http://www.semicon.panasonic.co.jp/en/>

Contents

■ Features	3
■ Applications	3
■ Package	3
■ Type	3
■ Block Diagram	4
■ Application Circuit Example	4
■ Pin Descriptions	5
■ Absolute Maximum Ratings	6
■ Operating Supply Voltage Range	6

Maintenance/Discontinued includes four Product lifecycle stage.
Discontinued
planned maintenance type
maintenance type
planned discontinued type
discontinued type
Please visit following URL about latest information.
<http://www.semicon.panasonic.co.jp/en/>

AN80T54

Multi voltage regulator IC

■ Features

- 5 outputs voltage regulator
- Peak current protection circuit
- Thermal protection circuit

■ Applications

- For power supply

■ Package

- SIL-12 pins plastic package (power type with fin)

■ Type

- Silicon monolithic bipolar IC

Maintenance/Discontinued

Maintenance/Discontinued includes following four Product lifecycle stage.
planned maintenance type
maintenance type
planned discontinued type
discontinued type
Please visit following URL about latest information.
<http://www.semicon.panasonic.co.jp/en/>

■ Block Diagram

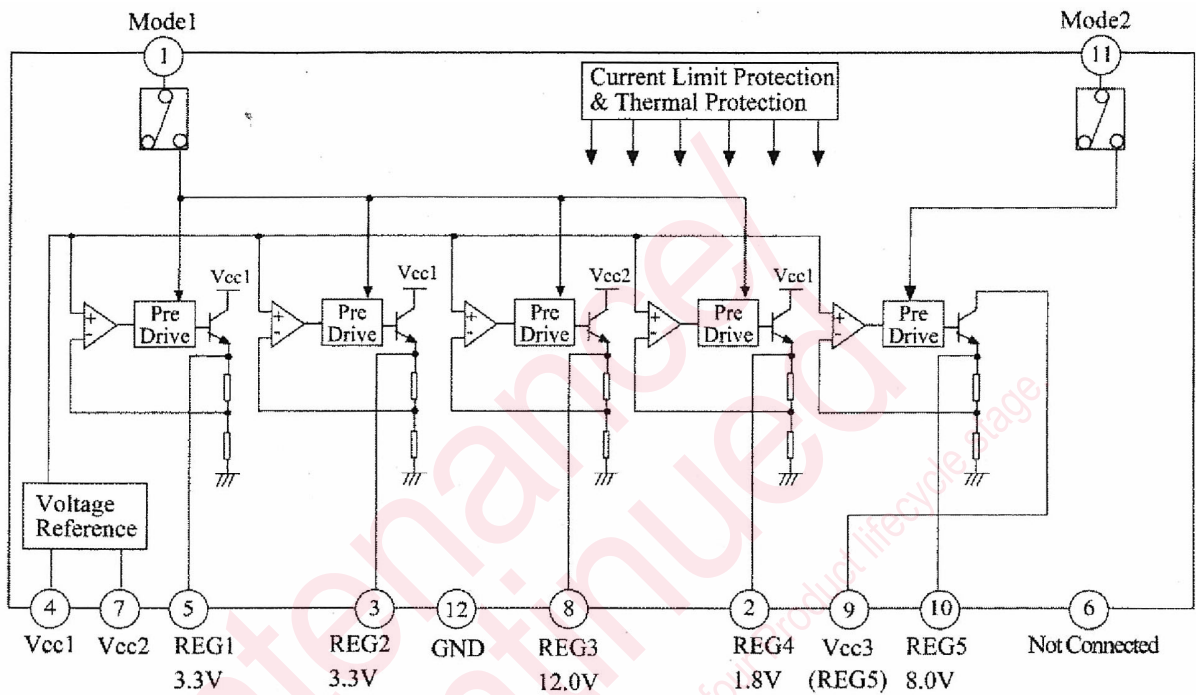

■ Application Circuit Example

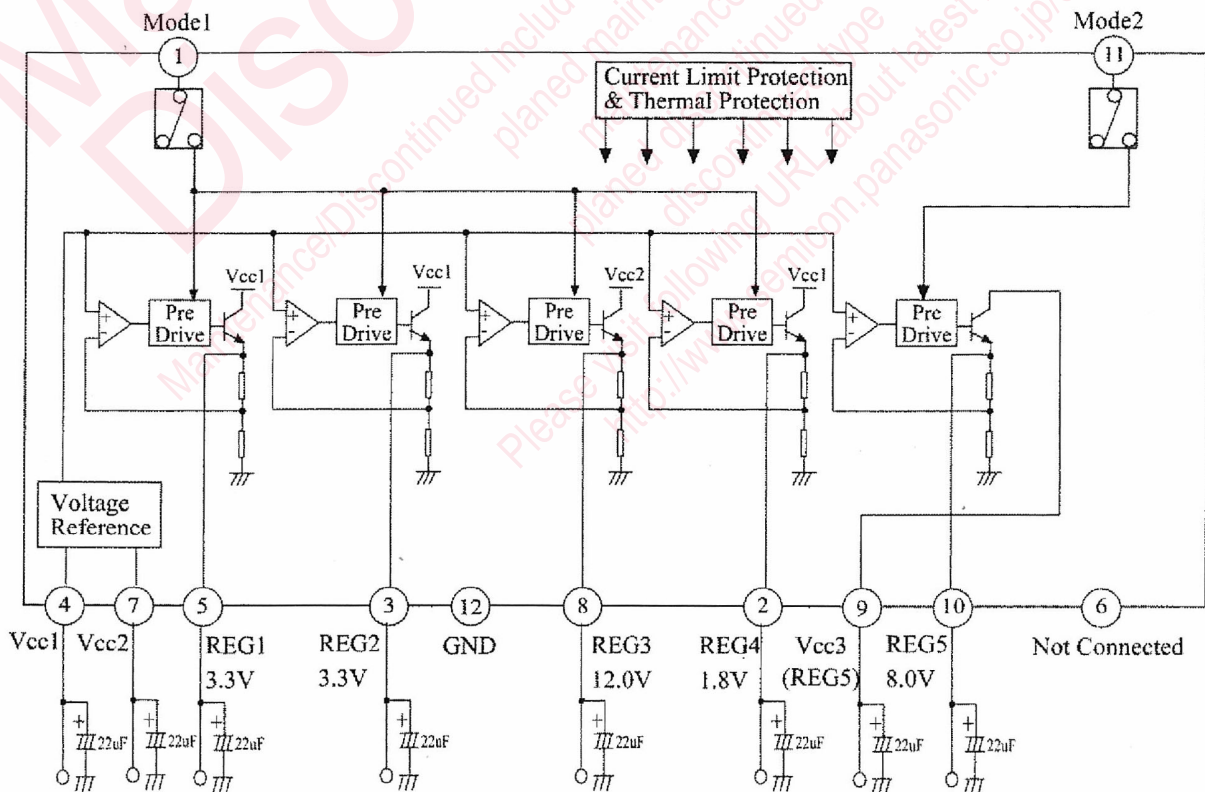

■ Pin Descriptions

Pin No.	Pin name	Description
1	MODE1	When MODE1 = 5 V, REG1, REG2, REG3 and REG4 outputs are "H".
2	REG4	When MODE1 pin is "H". REG4 output is 1.8 V ($I_O = 500$ mA min.).
3	REG2	When MODE1 pin is "H". REG2 output is 3.3 V ($I_O = 600$ mA min.).
4	VCC1	Connected to power supply.
5	REG1	When MODE1 pin is "H". REG1 output is 3.3 V ($I_O = 600$ mA min.).
6	Not Connected	
7	VCC2	Connected to power supply.
8	REG3	When MODE1 pin is "H". REG3 output is 12.0 V ($I_O = 150$ mA min.).
9	VCC3 (REG5)	Connected to power supply.
10	REG5	When MODE2 pin is "H". REG5 output is 8.0 V ($I_O = 300$ mA min.).
11	MODE2	When MODE2 = 5 V, REG5 output is "H".
12	GND	Connected to the IC substrate.

■ Absolute Maximum Ratings

A No.	Parameter	Symbol	Rating	Unit	Note
1	Storage temperature	T_{stg}	-55 to +150	°C	*1
2	Operating ambient temperature	T_{opr}	-25 to +75	°C	*1
3	Operating ambient pressure	P_{opr}	$1.013 \times 10^5 \pm 0.61 \times 10^5$	Pa	
4	Operating constant acceleration	G_{opr}	9 810	m/S ²	
5	Operating shock	S_{opr}	4 900	m/S ²	
6	Supply voltage	V_{CC1}	20.0	V	
		V_{CC2}	20.0		
		V_{CC3}	20.0		
7	Supply current	I_{CC}	6	A	*2
8	Power dissipation	P_D	12.5	W	*3
9	REG1 maximum current	I_{max1}	2.8	A	
10	REG2 maximum current	I_{max2}	2.8	A	
11	REG3 maximum current	I_{max3}	0.7	A	
12	REG4 maximum current	I_{max4}	2.8	A	
13	REG5 maximum current	I_{max5}	2.8	A	

Note) *1: Except these items, all other measurements are taken at $T_a = 25^\circ\text{C}$.

*2: Current limiting circuit.

*3: $T_a = 75^\circ\text{C}$ with 4.0°C/W heat sink attached at fin.

■ Operating Supply Voltage Range

Parameter	Symbol	Range	Unit	Note
Operating supply voltage range	V_{CC1}	3.7 to 7.0	V	
	V_{CC2}	13.5 to 17.0		
	V_{CC3}	11.0 to 17.0		

Request for your special attention and precautions in using the technical information and semiconductors described in this book

- (1) If any of the products or technical information described in this book is to be exported or provided to non-residents, the laws and regulations of the exporting country, especially, those with regard to security export control, must be observed.
- (2) The technical information described in this book is intended only to show the main characteristics and application circuit examples of the products, and no license is granted under any intellectual property right or other right owned by our company or any other company. Therefore, no responsibility is assumed by our company as to the infringement upon any such right owned by any other company which may arise as a result of the use of technical information described in this book.
- (3) The products described in this book are intended to be used for standard applications or general electronic equipment (such as office equipment, communications equipment, measuring instruments and household appliances).
Consult our sales staff in advance for information on the following applications:
 - Special applications (such as for airplanes, aerospace, automobiles, traffic control equipment, combustion equipment, life support systems and safety devices) in which exceptional quality and reliability are required, or if the failure or malfunction of the products may directly jeopardize life or harm the human body.
 - Any applications other than the standard applications intended.
- (4) The products and product specifications described in this book are subject to change without notice for modification and/or improvement. At the final stage of your design, purchasing, or use of the products, therefore, ask for the most up-to-date Product Standards in advance to make sure that the latest specifications satisfy your requirements.
- (5) When designing your equipment, comply with the range of absolute maximum rating and the guaranteed operating conditions (operating power supply voltage and operating environment etc.). Especially, please be careful not to exceed the range of absolute maximum rating on the transient state, such as power-on, power-off and mode-switching. Otherwise, we will not be liable for any defect which may arise later in your equipment.
 - Even when the products are used within the guaranteed values, take into the consideration of incidence of break down and failure mode, possible to occur to semiconductor products. Measures on the systems such as redundant design, arresting the spread of fire or preventing glitch are recommended in order to prevent physical injury, fire, social damages, for example, by using the products.
- (6) Comply with the instructions for use in order to prevent breakdown and characteristics change due to external factors (ESD, EOS, thermal stress and mechanical stress) at the time of handling, mounting or at customer's process. When using products for which damp-proof packing is required, satisfy the conditions, such as shelf life and the elapsed time since first opening the packages.
- (7) This book may be not reprinted or reproduced whether wholly or partially, without the prior written permission of Matsushita Electric Industrial Co., Ltd.



LittleDiode supplies new, hard to find or obsolete electronic components and semiconductors all over the world.

With over two million different components listed you are sure to find the part you need.

Feel free to visit us today at our online store:

LittleDiode.com

Looking forward to providing you with the best possible service.