

# AN8208S

## FDD Stepping Motor Drive IC

### Overview

The AN8208S is a driver IC for excitation of 1/2 phase coil in FDD stepping motor.

### Features

- Operating supply voltage range :  $V_{CC}=4.4V$  to  $6V$
- Stepping motor 1/2 phase coil excitation
- Stand-by mode function incorporated
- PNP,NPN complementary full-bridge output,realizing low power dissipation
- Miniaturized surface mounting package

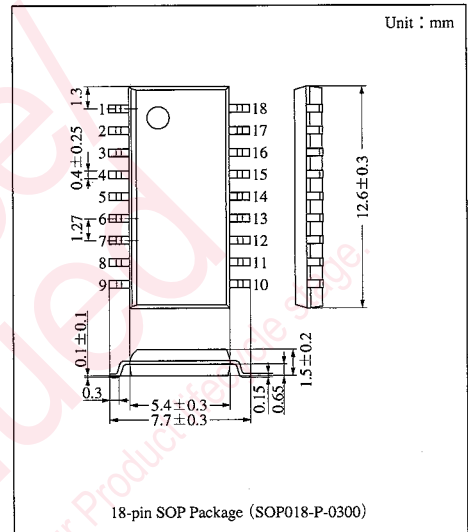

### Block Diagram

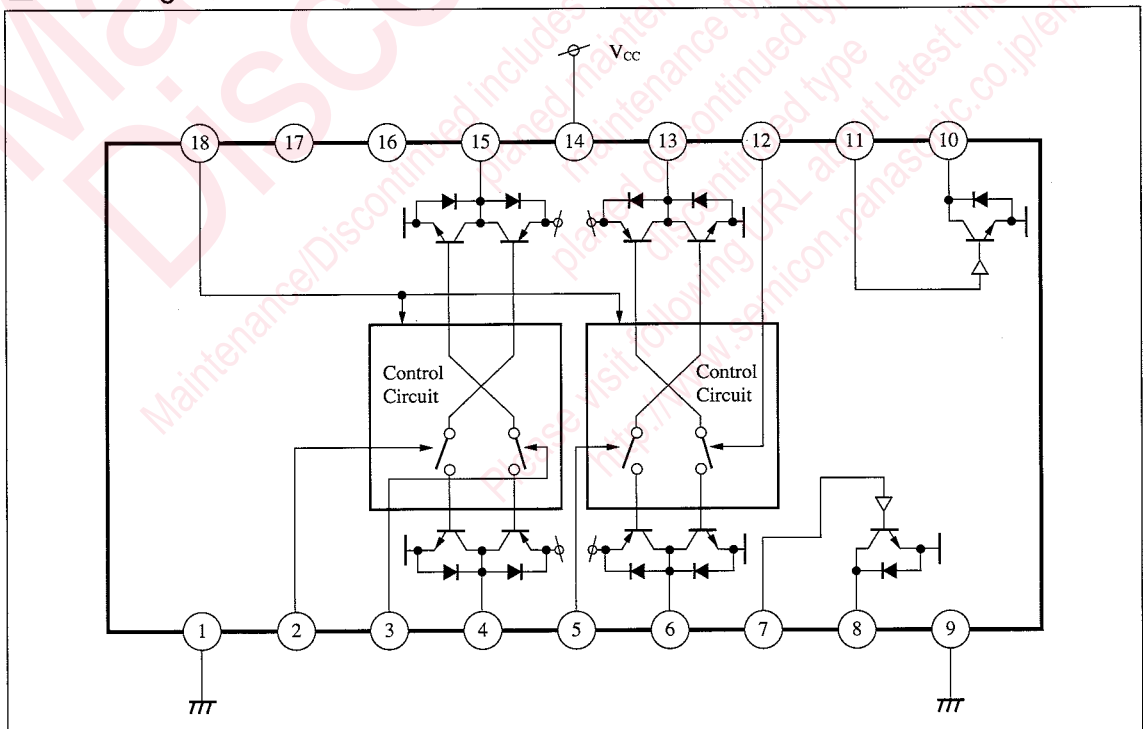

## Pin Descriptions

Pin No.	Pin name	Pin No.	Pin name
1	GND1	10	Fout (inverter output)
2	Ain ( $\phi$ 1 input)	11	Fin (inverter input)
3	Bin ( $\phi$ 1 input)	12	Din ( $\phi$ 2 input)
4	Bout (to S-motor winding 1)	13	Dout (to S-motor winding 2)
5	Cin ( $\phi$ 2 input)	14	V <sub>CC</sub>
6	Cout (to S-motor winding 2)	15	Aout (to S-motor winding 1)
7	Ein (inverter input)	16	NC
8	Eout (inverter output)	17	NC
9	GND2	18	STB (H for stand-by mode)

## Absolute Maximum Rating (Ta = 25 °C)

Parameter	Symbol	Rating	Unit
Supply voltage	V <sub>CC</sub>	6.5	V
Supply current	I <sub>CC</sub>	800	A
Power dissipation <sup>Note)</sup>	P <sub>D</sub>	185	mW
Operating ambient temperature	T <sub>opr</sub>	-20 to +75	°C
Storage temperature	T <sub>stg</sub>	-55 to +125	°C

Note) Package power dissipation under free air and operating ambient temperature Ta of 75°C.

## Recommended Operating Range (Ta = 25°C)

Parameter	Symbol	Range
Operating supply voltage	V <sub>CC</sub>	4.4V to 6.0V

## Electrical Characteristics (V<sub>CC</sub> = 5V, Ta = 25 ± 2°C)

Parameter	Symbol	Condition	min	typ	max	Unit
<b>Input Terminal (Ain, Bin, Cin, Din, Ein, Fin)</b>						
(L) input level	V <sub>inL</sub>		-0.3	—	0.8	V
(L) level input current	I <sub>inL</sub>	V <sub>in</sub> = 0V	-2	—	2	μA
(H) input level	V <sub>inH</sub>		2.8	—	5.3	V
(H) level input current	I <sub>inH</sub>	V <sub>in</sub> = 5V	—	—	1	mA
<b>Input Terminal (STB)</b>						
(L) input level	V <sub>STBL</sub>		-0.3	—	2.8	V
(L) level input current	I <sub>STBL</sub>	V <sub>STBL</sub> = 0V	-1	—	—	mA
(H) input level	V <sub>STBH</sub>		4	—	5.3	V
(H) level input current	I <sub>STBH</sub>	V <sub>STBL</sub> = 5V	-300	—	300	μA
<b>Output Terminals (Aout, Bout, Cout, Dout)</b>						
(L) output voltage	V <sub>OL</sub>	I <sub>L</sub> = 300mA V <sub>in</sub> = 2.8V	—	0.3	0.4	V
(H) output voltage	V <sub>OH</sub>	I <sub>L</sub> = 300mA V <sub>in</sub> = 2.8V	4.6	4.7	—	V
<b>Others</b>						
EoutL output voltage	V <sub>OLE</sub>	I <sub>L</sub> = 50mA	—	0.35	0.5	V
FoutL output voltage	I <sub>OLF</sub>	I <sub>L</sub> = 30mA	—	0.35	0.5	V
Stand-by current	I <sub>OS</sub>	Total V <sub>in</sub> = 0V	—	—	10	μA

ICs for  
Motor

## Pin Descriptions

Pin No.	Pin name	Function description
1	GND1	GND terminal
2	AIN	Terminal inputting the signal of phase 1. For (H) input of this signal, (H) (source drive) is outputted to AOUT and (L) (sink drive) to BOUT.
3	BIN	Terminal inputting the signal of phase 1. For (H) input of this signal, (H) (source drive) is outputted to BOUT and (L) (sink drive) to AOUT.
4	BOUT	It is connected to one end of the stepping motor winding 1.
5	CIN	Terminal inputting the signal of phase 1. For (H) input of this signal, (H) (source drive) is outputted to COUT and (L) (sink drive) to DOUT.
6	COUT	It is connected to one end of the stepping motor winding 2.
7	EIN	It constructs the inverter of 50 mA open collector.
8	EOUT	
9	GND2	GND terminal
10	FOUT	It constructs the inverter of 30 mA open collector.
11	FIN	
12	DIN	Input terminal for phase 2 negative logic. For (H) input of this signal, (H) (source drive) is outputted to DOUT and (L) (sink drive) to COUT.
13	DOUT	It is connected to one end of the stepping motor winding 2.
14	V <sub>CC</sub>	V <sub>CC</sub> terminal
15	AOUT	It is connected to one end of the stepping motor winding 1.
16	NC	NC terminal
17	NC	
18	STB	For (H) input, the IC enters the stand-by mode (non-excitation) . It means AOUT, BOUT, COUT and DOUT enter in the open condition.

## Package Power Dissipation

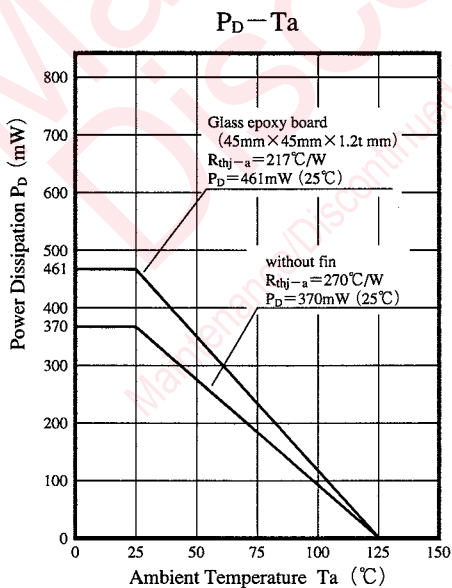

■ Operation Logic

	AIN (Pin②)	BIN (Pin③)	CIN (Pin⑤)	DIN (Pin⑫)	STB (Pin⑱)		AOUT (Pin⑮)	BOUT (Pin④)	COUT (Pin⑥)	DOUT (Pin⑬)
OFF	0	0	0	0	*		F	F	F	F
Stand-by	*	*	*	*	1		F	F	F	F
Rest	0	0	*	*	0		F	F	U	U
Normal direction	1	0	*	*	0		H	L	U	U
Reverse direction	0	1	*	*	0		L	H	U	U
Not used	1	1	*	*	0		H	H	U	U
Rest	*	*	0	0	0		U	U	F	F
Normal direction	*	*	1	0	0		U	U	H	L
Reverse direction	*	*	0	1	0		U	U	L	H
Not used	*	*	1	1	0		U	U	H	H

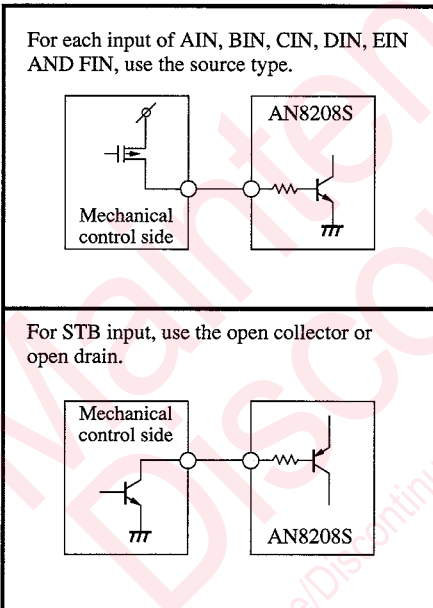

Symbol Description	1	"H" input
	0	"L" input
	*	Uncertain input (not specified)
	H	"H" level output
	L	"H" level output
	F	Release output
	U	Not specified

ICs for Motor

## Request for your special attention and precautions in using the technical information and semiconductors described in this book

- (1) If any of the products or technical information described in this book is to be exported or provided to non-residents, the laws and regulations of the exporting country, especially, those with regard to security export control, must be observed.
- (2) The technical information described in this book is intended only to show the main characteristics and application circuit examples of the products. No license is granted in and to any intellectual property right or other right owned by Panasonic Corporation or any other company. Therefore, no responsibility is assumed by our company as to the infringement upon any such right owned by any other company which may arise as a result of the use of technical information described in this book.
- (3) The products described in this book are intended to be used for standard applications or general electronic equipment (such as office equipment, communications equipment, measuring instruments and household appliances).  
Consult our sales staff in advance for information on the following applications:
  - Special applications (such as for airplanes, aerospace, automobiles, traffic control equipment, combustion equipment, life support systems and safety devices) in which exceptional quality and reliability are required, or if the failure or malfunction of the products may directly jeopardize life or harm the human body.
  - Any applications other than the standard applications intended.
- (4) The products and product specifications described in this book are subject to change without notice for modification and/or improvement. At the final stage of your design, purchasing, or use of the products, therefore, ask for the most up-to-date Product Standards in advance to make sure that the latest specifications satisfy your requirements.
- (5) When designing your equipment, comply with the range of absolute maximum rating and the guaranteed operating conditions (operating power supply voltage and operating environment etc.). Especially, please be careful not to exceed the range of absolute maximum rating on the transient state, such as power-on, power-off and mode-switching. Otherwise, we will not be liable for any defect which may arise later in your equipment.
  - Even when the products are used within the guaranteed values, take into the consideration of incidence of break down and failure mode, possible to occur to semiconductor products. Measures on the systems such as redundant design, arresting the spread of fire or preventing glitch are recommended in order to prevent physical injury, fire, social damages, for example, by using the products.
- (6) Comply with the instructions for use in order to prevent breakdown and characteristics change due to external factors (ESD, EOS, thermal stress and mechanical stress) at the time of handling, mounting or at customer's process. When using products for which damp-proof packing is required, satisfy the conditions, such as shelf life and the elapsed time since first opening the packages.
- (7) This book may be not reprinted or reproduced whether wholly or partially, without the prior written permission of our company.



LittleDiode supplies new, hard to find or obsolete electronic components and semiconductors all over the world.

With over two million different components listed you are sure to find the part you need.

Feel free to visit us today at our online store:

**[LittleDiode.com](http://LittleDiode.com)**

Looking forward to providing you with the best possible service.