

AN8353UB

High Efficiency Car Dashboard Dimmer IC

■ Overview

The AN8353UB is a dimmer IC to control illumination of the car dashboard at high efficiency and high performance by pulse width control. It outputs pulses at a duty proportional to an input voltage.

■ Features

- Low power consumption by pulse control
- External ON/OFF control by the standby pin
- Pulse frequency range : 50Hz to 10kHz
- Built-in overvoltage protective circuit approx. 20V
- Wide operating ambient temperature range : -40°C to $+100^{\circ}\text{C}$
- All products temperature cycle, high reliability by normal and high temperature checks reliability equivalent to the air bags requested in U.S.

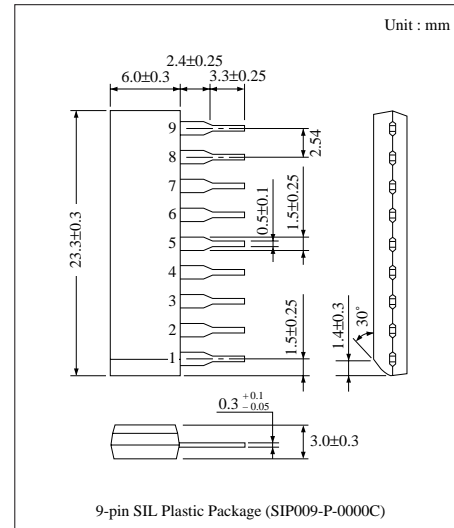

■ Block Diagram

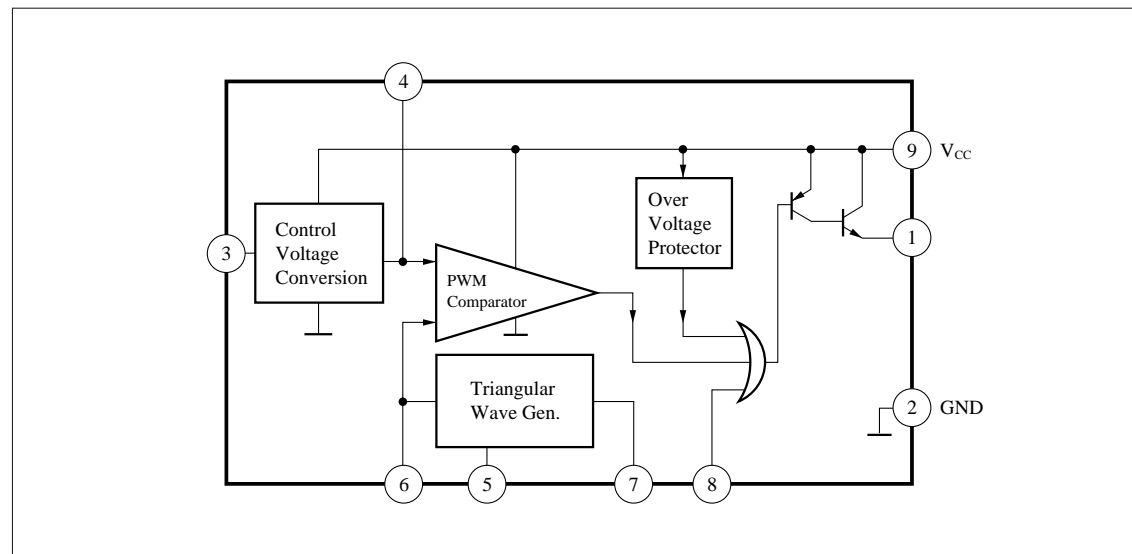

■ Pin Descriptions

Pin No.	Pin name	Description
1	Output pin	Outputs an intermittent source current at a duty proportional to an input voltage
2	GND	GND
3	Input pin	Applies a control voltage.
4	Noise eliminating capacity connection pin 1	Connect a capacitor to eliminator a noise.
5	Square wave output pin	Output a triangular wave, which serves as a reference for the PWM signal, to the Pin6 by connecting the resistor R_T between the Pins5 and6, and capacity C_T between the Pin6 and GND.
6	Triangular wave output pin	Output a triangular wave, which serves as a reference for the PWM signal, to this pin by connecting the resistor R_T between the Pins6 and 5, and capacity C_T between the Pin6 and GND.
7	Noise eliminating capacity connection pin 2	Connect a capacitor to eliminator a noise.
8	Standby pin	Forces to shut off an output current if a voltage higher than a threshold voltage of 1.1V is applied to the Pin8.
9	V_{CC}	Supply Voltage

■ Absolute Maximum Ratings (Ta=25°C)

Parameter	Symbol	Rating	Unit
Supply voltage	V_{CC}	22	V
Power dissipation	P_D	550	mW
Storage temperature	T_{opr}	-40 to +100	°C
Operating ambient temperature	T_{stg}	-50 to +150	°C

■ Recommended Operating Range (Ta=25°C)

Parameter	Symbol	Range
Operating supply voltage range	V_{CC}	8 to 18V

■ Electrical Characteristics (Ta=25°C)

Parameter	Symbol	Condition	min	typ	max	Unit
Supply current	I_{CC}	Eliminate C_T and R_T	4	7.5	11	mA
Oscillation frequency	f_{osc}	$C_T=0.027\mu F$	90	115	140	Hz
0% duty input voltage	V_{IN-0}	$C_T=0.027\mu F$	2	2.5	3	V
100% duty input voltage	V_{IN-100}	$C_T=0.027\mu F$	9.5	10	10.5	V
Center duty ($V_{CC}=12V$)	D_{12V}	$C_T=0.027\mu F$	35	45	55	%
Center duty ($V_{CC}=8V$)	DD_{8V}	$C_T=0.027\mu F$	-1	0	1	%
Center duty ($V_{CC}=18V$)	DD_{18V}	$C_T=0.027\mu F$	-1	0	1	%
Output duty gain	D_G	$C_T=0.027\mu F$	45	50	55	%
Output voltage at ON	V_{ON}	$C_T=2100pF$	0.6	0.9	1.2	V
Leakage current at OFF	I_L	$C_T=2100pF$	—	0	4	μA
Over voltage detection voltage	V_{OV}	$C_T=2100pF$	18	20	22	V
Standby threshold voltage	V_{STH}	$C_T=2100pF$	0.55	1.1	1.65	V

■ Application Circuit

• Bipolar Transistor Output

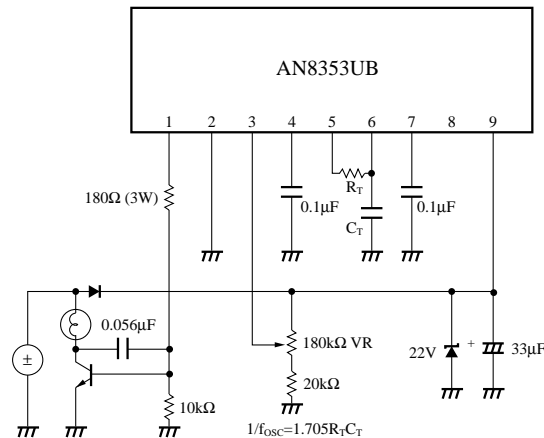

• MOS FET Output

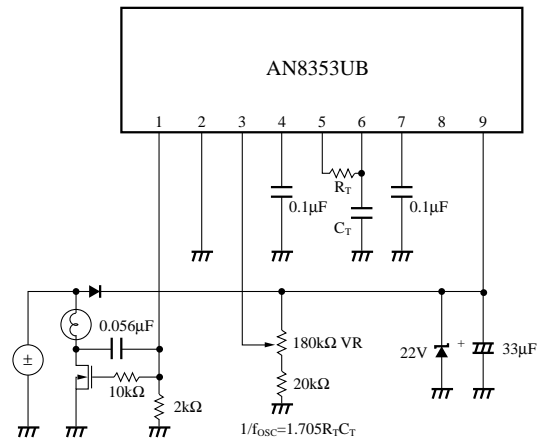

■ Supplementary Description

• System Operational Principle

The following describes the operational principle of the system using the AN8353UB.

As shown in the block diagram in Fig. 1, a battery voltage is divided by the VR and input to the input Pin3 in accordance with rotation amount. The voltage at the output Pin1 is controlled by the AN8353UB so that the duty of the ON/OFF period of the external output transistor will be proportional to the input voltage, thus controlling a current flowing to the lamps of the dashboard, etc. to adjust their brightness. Since the output transistors are saturated at ON time and no current flows at OFF time, power consumption is low.

The PWM method is used to control the output transistors. This method, as shown in Fig. 2 I/O Characteristic Chart (III), generates the triangular wave V_6 as a reference signal

to generate pulses and input them to one end (Pin6) of the PWM comparator. The triangular wave frequency f_{osc} can be freely set from 50Hz to 10kHz, depending on the resistance value R_T connected between the square wave output Pin5 and triangular wave output Pin6, and capacity value C_T connected between the triangular wave output Pin6 and ground Pin2. The approximating expression for the then PWM frequency f_{osc} is ;

$$1/f_{osc} = 1.705 C_T R_T \dots \dots \dots (1)$$

For your reference, Fig. 3 shows the relations among C_T , R_T , and oscillation frequency f_{osc} . The voltage V_4 , whose voltage level is made matching the amplitude of the triangular wave by the control voltage converter, is given to the other input (Pin4) of the PWM comparator. That is, in Fig. 2 (II), the input voltage V_3 is linearly converted into V_4 by the control voltage converter so that the amplitude of the triangular wave will be about 20% to 80% of the input voltage input range (axis of abscissas in Fig. 2 (II)).

Then, a current is supplied from the output Pin1 to turn on the output transistors during the period (T_{ON}) when the inverted input voltage is larger than the triangular wave. (Fig. 2 (II), (IV)) To the contrary, while the converted input voltage is smaller than the triangular wave, no current is supplied from the output Pin1 and the output transistors are turned off. The output pulse duty is expressed as follows.

$$\text{Duty} = T_{ON} \cdot f_{osc} \dots \dots \dots (2)$$

For the duty control characteristic of the output pulses to the input voltage V_3 , the duty of the output pulses is controlled from 0% to 100% at high-precision linearity while the “input voltage V_3 /supply voltage V_9 ” is between about

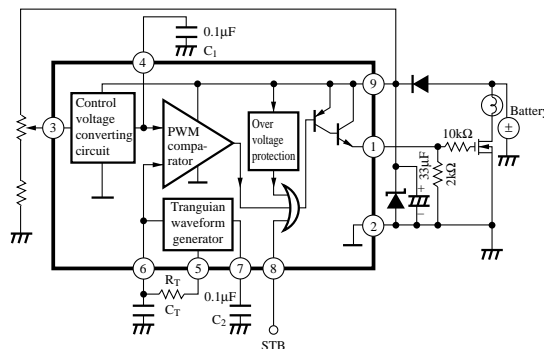

Fig. 1 AN8353UB Block Diagram

■ Supplementary Description (cont.)

• System Operational Principle (cont.)

0.2 (B-point) and 0.8 (C-point). The A-point in the figure shows the I/O characteristics when the “input voltage V_3 /supply voltage V_9 ” is 0.7. And, when V_3/V_9 is from 0.05V to about 0.2V (B-point), the duty is controlled to 0%, and when V_3/V_9 is from 0.8V (C-point) to 1.0V, the duty is controlled to 100%.

The standby Pin8 can forcibly turn off the output transistors by applying a voltage of about 1.1V or more to this pin. When it is not necessary to forcibly turn off the output transistors, Leave the standby Pin8 open.

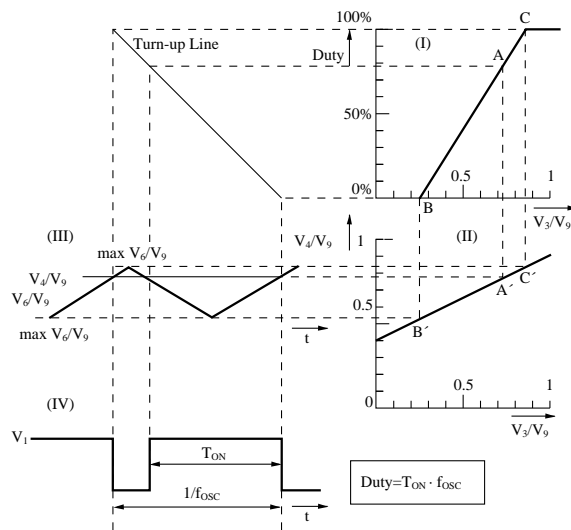

Fig. 2 I/O Characteristic Chart

• Over voltage Detecting Voltage vs. Output

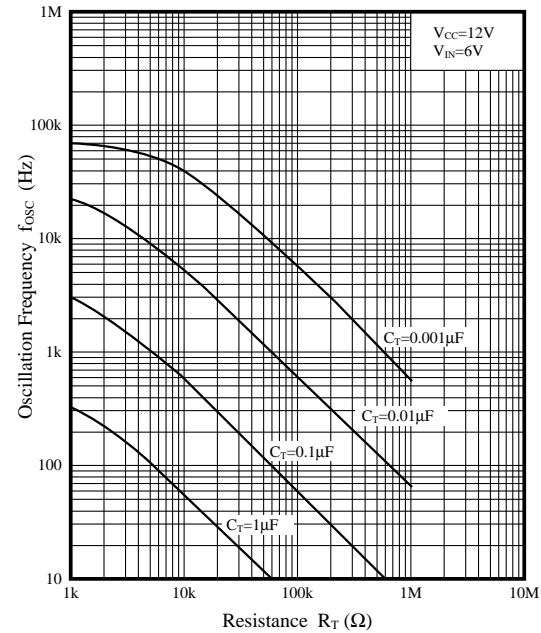
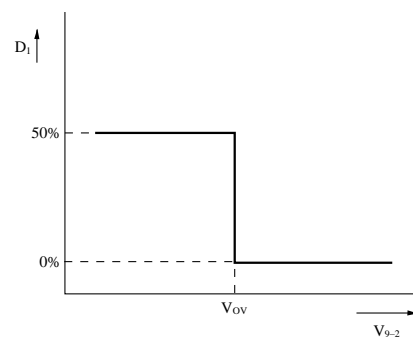
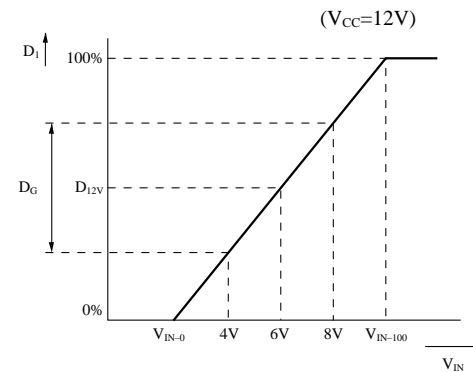

Fig. 3 Relations between Oscillation Frequency and C_T and R_T

• Duty D_1 vs. Input Voltage V_{IN}



• Output voltage at ON V_{ON} • Leakage current at OFF

$$V_{ON} = V_{CC} - V_{1-2}$$

$$I_L = \frac{V_{1-2}}{1M\Omega}$$

• Standby Threshold Voltage vs. Output

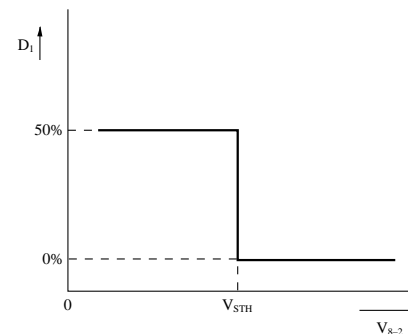

Request for your special attention and precautions in using the technical information and semiconductors described in this material

- (1) An export permit needs to be obtained from the competent authorities of the Japanese Government if any of the products or technologies described in this material and controlled under the "Foreign Exchange and Foreign Trade Law" is to be exported or taken out of Japan.
- (2) The technical information described in this material is limited to showing representative characteristics and applied circuit examples of the products. It does not constitute the warranting of industrial property, the granting of relative rights, or the granting of any license.
- (3) The products described in this material are intended to be used for standard applications or general electronic equipment (such as office equipment, communications equipment, measuring instruments and household appliances).
Consult our sales staff in advance for information on the following applications:
 - Special applications (such as for airplanes, aerospace, automobiles, traffic control equipment, combustion equipment, life support systems and safety devices) in which exceptional quality and reliability are required, or if the failure or malfunction of the products may directly jeopardize life or harm the human body.
 - Any applications other than the standard applications intended.
- (4) The products and product specifications described in this material are subject to change without notice for reasons of modification and/or improvement. At the final stage of your design, purchasing, or use of the products, therefore, ask for the most up-to-date Product Standards in advance to make sure that the latest specifications satisfy your requirements.
- (5) When designing your equipment, comply with the guaranteed values, in particular those of maximum rating, the range of operating power supply voltage and heat radiation characteristics. Otherwise, we will not be liable for any defect which may arise later in your equipment.
Even when the products are used within the guaranteed values, redundant design is recommended, so that such equipment may not violate relevant laws or regulations because of the function of our products.
- (6) When using products for which dry packing is required, observe the conditions (including shelf life and after-unpacking standby time) agreed upon when specification sheets are individually exchanged.
- (7) No part of this material may be reprinted or reproduced by any means without written permission from our company.

Please read the following notes before using the datasheets

- A. These materials are intended as a reference to assist customers with the selection of Panasonic semiconductor products best suited to their applications.
Due to modification or other reasons, any information contained in this material, such as available product types, technical data, and so on, is subject to change without notice.
Customers are advised to contact our semiconductor sales office and obtain the latest information before starting precise technical research and/or purchasing activities.
- B. Panasonic is endeavoring to continually improve the quality and reliability of these materials but there is always the possibility that further rectifications will be required in the future. Therefore, Panasonic will not assume any liability for any damages arising from any errors etc. that may appear in this material.
- C. These materials are solely intended for a customer's individual use.
Therefore, without the prior written approval of Panasonic, any other use such as reproducing, selling, or distributing this material to a third party, via the Internet or in any other way, is prohibited.



LittleDiode supplies new, hard to find or obsolete electronic components and semiconductors all over the world.

With over two million different components listed you are sure to find the part you need.

Feel free to visit us today at our online store:

LittleDiode.com

Looking forward to providing you with the best possible service.