

AN8481SB

Spindle motor driver IC for optical disk

■ Overview

The AN8481SB is a high performance IC suited for driving a spindle motor of an optical disk such as CD-ROM, PD, DVD, CD-R, CD-RW, etc.

■ Features

- Adopting the 3-phase full-wave soft switch system
- With switching regulator control function
- With start and stop pin
- Reverse braking by EC/ECR voltage
- With Hall bias pin
- Surface-mount small package

■ Applications

- High speed CD-ROM drive
- PD, DVD, CD-R, CD-RW drives

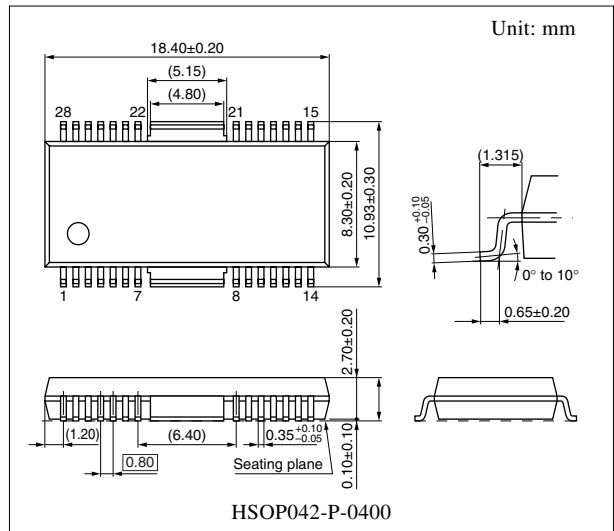

Note) The package of this product will be changed to lead-free type (HSOP042-P-0400D). See the new package dimensions section later of this datasheet.

■ Block Diagram

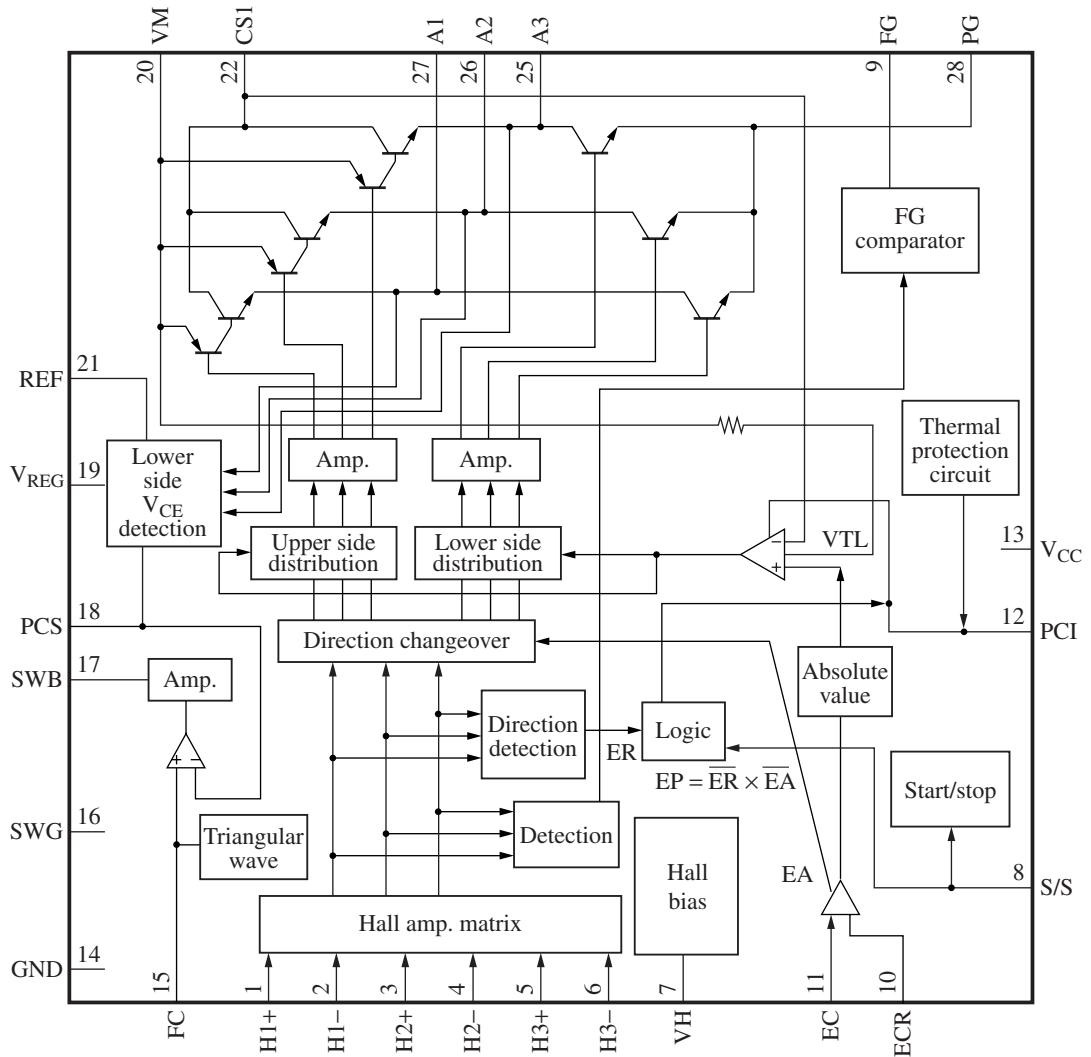

■ Pin Descriptions

Pin No.	Symbol	Description	Pin No.	Symbol	Description
1	H1+	Hall element-1 positive input pin	11	EC	Torque command input pin
2	H1-	Hall element-1 negative input pin	12	PCI	Current feedback phase compensation pin
3	H2+	Hall element-2 positive input pin	13	V _{CC}	Supply voltage pin
4	H2-	Hall element-2 negative input pin	14	SG	Signal GND pin
5	H3+	Hall element-3 positive input pin	15	FC	Triangular wave oscillation pin
6	H3-	Hall element-3 negative input pin	16	SWG	SW-REG system GND pin
7	VH	Hall bias pin	17	SWB	SW-REG driving pin
8	SS	Start/stop changeover pin	18	PCS	SW-REG system phase compensation pin
9	FG	FG signal output pin	19	V _{REG}	Fixed power supply pin
10	ECR	Torque command reference input pin	20	VM	Motor supply voltage pin

■ Pin Descriptions (continued)

Pin No.	Symbol	Description	Pin No.	Symbol	Description
21	REF	SW-REG reference setting pin	25	A3	Drive output 3
22	CS1	Current det. pin 1	26	A2	Drive output 2
23	N.C.	N.C.	27	A1	Drive output 1
24	N.C.	N.C.	28	PG	Power GND pin

■ Absolute Maximum Ratings

Parameter	Symbol	Rating	Unit
Supply voltage	V_{CC}	7.0	V
	V_M	14.4	
	V_{REG}		
Control signal input voltage *4	$V_{(n)}$	0 to V_{CC}	V
Supply current	I_{CC}	30	mA
Output current *3	$I_{O(n)}$	± 1 200	mA
Hall bias current	I_{HB}	50	mA
Power dissipation *2	P_D	667	mW
Operating ambient temperature *1	T_{opr}	-20 to +70	°C
Storage temperature *1	T_{stg}	-55 to +150	°C

Note) Do not apply external currents or voltages to any pins not specifically mentioned.

For circuit currents, '+' denotes current flowing into the IC, and '-' denotes current flowing out of the IC.

*1: Except for the operating ambient temperature and storage temperature, all ratings are for $T_a = 25^\circ\text{C}$.

*2: For 70°C and IC alone.

*3: n = 22, 25, 26, 27, 28

*4: n = 1, 2, 3, 4, 5, 6, 8, 10, 11

■ Recommended Operating Range

Parameter	Symbol	Range	Unit
Supply voltage	V_{CC}	4.25 to 5.5	V
	V_M	4.5 to 14	
	V_{REG}		

■ Electrical Characteristics at $T_a = 25^\circ\text{C}$

Parameter	Symbol	Conditions	Min	Typ	Max	Unit
Overall						
Circuit current 1	I_{CC1}	$V_{CC} = 5$ V in power save mode	—	0	0.1	mA
Circuit current 2	I_{CC2}	$V_{CC} = 5$ V, $I_O = 0$ mA	—	8	16	mA
Start/stop						
Start voltage	V_{START}	Voltage with which a circuit operates at $V_{CC} = 5$ V and L \rightarrow H	3.5	—	—	V
Stop voltage	V_{STOP}	Voltage with which a circuit becomes off at $V_{CC} = 5$ V and H \rightarrow L	—	—	1.0	V

■ Electrical Characteristics at $T_a = 25^\circ\text{C}$ (continued)

Parameter	Symbol	Conditions	Min	Typ	Max	Unit
Hall bias						
Hall bias voltage	V_{HB}	$V_{CC} = 5\text{ V}$, $I_{HB} = 20\text{ mA}$	0.7	1.2	1.6	V
Hall amplifier						
Input bias current	I_{BH}	$V_{CC} = 5\text{ V}$	—	1	5	μA
In-phase input voltage range	V_{HBR}	$V_{CC} = 5\text{ V}$	1.5	—	4.0	V
Minimum input level	V_{INH}	$V_{CC} = 5\text{ V}$	60	—	—	mV[p-p]
Torque command						
In-phase input voltage range	EC	$V_{CC} = 5\text{ V}$	1	—	3.9	V
Offset voltage	EC_{OF}	$V_{CC} = 5\text{ V}$	-150	0	150	mV
Dead zone	EC_{DZ}	$V_{CC} = 5\text{ V}$	50	100	150	mV
Input current	EC_{IN}	$V_{CC} = 5\text{ V}$, $EC = ECR = 2.5\text{ V}$	-5	-1	—	μA
Input/output gain	A_{CS}	$V_{DD} = 5\text{ V}$, $R_{CS} = 0.5\ \Omega$	0.31	0.41	0.51	A/V
Output						
High-level output saturation voltage	V_{OH}	$V_{CC} = 5\text{ V}$, $I_O = -300\text{ mA}$	—	0.9	1.6	V
Low-level output saturation voltage	V_{OL}	$V_{CC} = 5\text{ V}$, $I_O = 300\text{ mA}$	—	0.2	0.6	V
Torque limit current	I_{TL}	$V_{CC} = 5\text{ V}$, $R_{CS} = 0.5\ \Omega$	390	530	670	mA
FG						
FG output high-level	FG_H	$V_{CC} = 5\text{ V}$, $I_{FG} = -0.01\text{ mA}$	3.0	—	V_{CC}	V
FG output low-level	FG_L	$V_{CC} = 5\text{ V}$, $I_{FG} = 0.01\text{ mA}$	—	—	0.5	V
In-phase input voltage range	V_{FGR}	$V_{CC} = 5\text{ V}$, Input D-range at H2+, H2-	1.5	—	3.0	V
FG hysteresis width	H_{FG}	$V_{CC} = 5\text{ V}$	1	10	20	mV
Triangular wave oscillation circuit						
Charging current	I_{CH}	$V_{CC} = 5\text{ V}$, $FC = 0.5\text{ V}$	-100	-50	-25	μA
Discharging current	I_{DCH}	$V_{CC} = 5\text{ V}$, $FC = 2.5\text{ V}$	25	50	100	μA
Lower side voltage detection circuit						
Input to output gain	G_{VI}	$V_{CC} = 5\text{ V}$	5	10	20	times
SW-REG driving circuit						
PNP driving current	I_{SWB}	$V_{CC} = 5\text{ V}$	10	50	—	mA

• Design reference data

Note) The characteristics listed below are theoretical values based on the IC design and are not guaranteed.

Parameter	Symbol	Conditions	Min	Typ	Max	Unit
Thermal protection						
Thermal protection operating temperature	T_{SDON}	$V_{CC} = 5\text{ V}$, $\Delta EC = 100\text{ mV}$	—	170	—	$^\circ\text{C}$
Thermal protection hysteresis width	ΔT_{SD}	$V_{CC} = 5\text{ V}$, $\Delta EC = 100\text{ mV}$	—	45	—	$^\circ\text{C}$

■ Usage Notes

Prevent this IC from being line-to-ground fault. (To be concrete, do not short-circuit any of pins A1 (pin 27), A2 (pin 26) and A3 (pin 25) to V_{REG} pin (pin 19) or VM pin (pin 20).)

■ Application Notes

- $P_D - T_a$ curves of HSOP042-P-0400

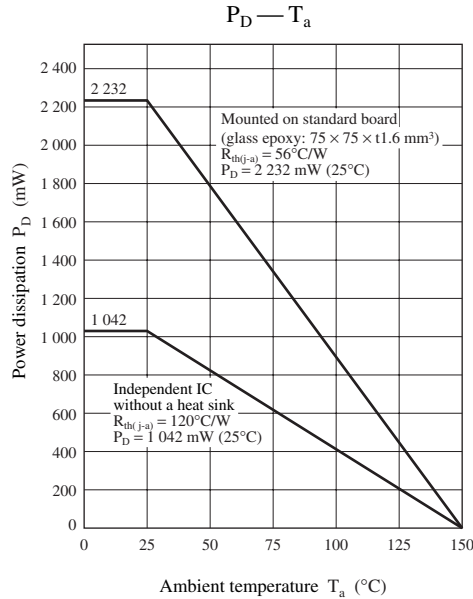

- Phase conditions between Hall input and output current

Phase of Hall pin			
	H1+	H2+	H3+
A	H	M	L
B	H	L	M
C	M	L	H
D	L	M	H
E	L	H	M
F	M	H	L

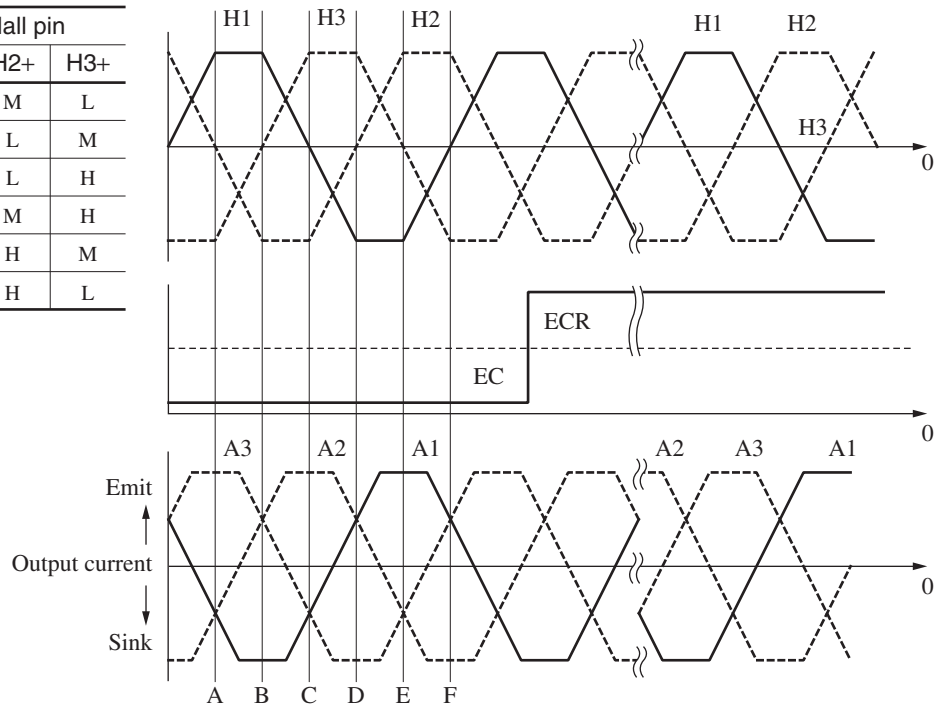

■ Application Circuit Example

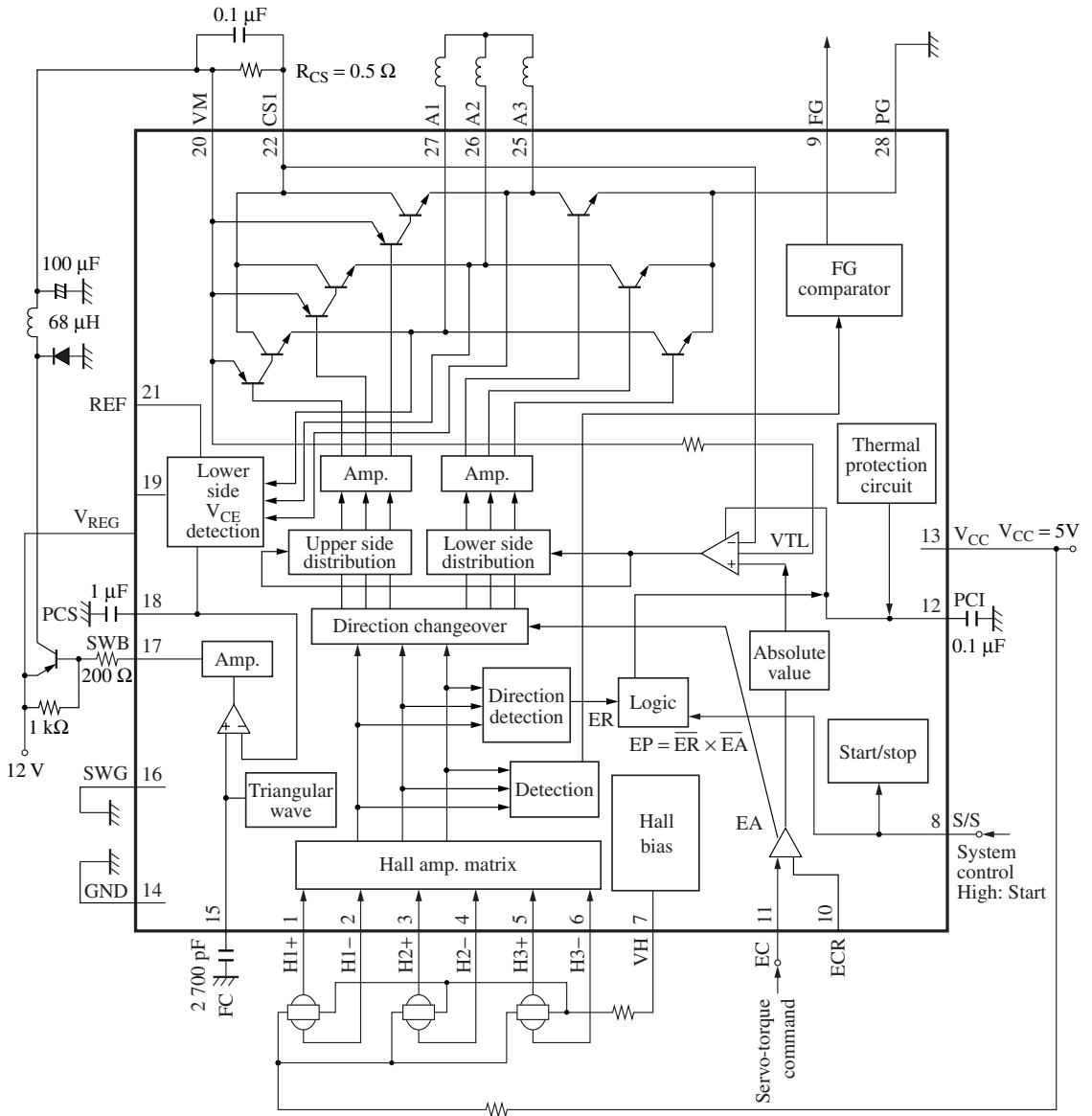

■ New Package Dimensions (Unit: mm)

- HSOP042-P-0400D (Lead-free package)

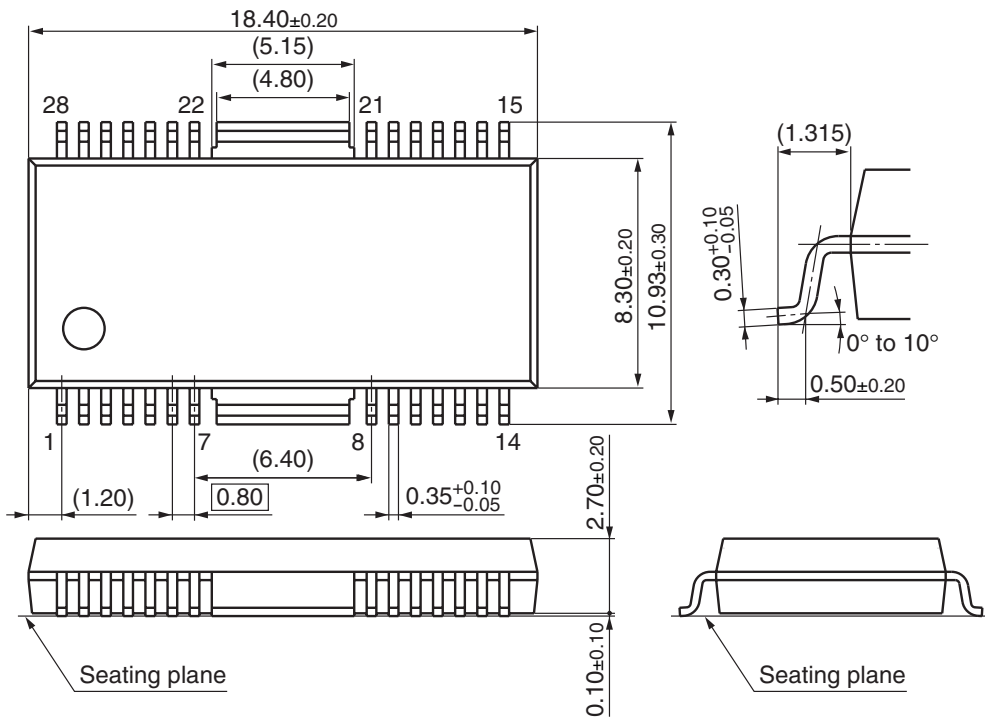

Request for your special attention and precautions in using the technical information and semiconductors described in this material

- (1) An export permit needs to be obtained from the competent authorities of the Japanese Government if any of the products or technologies described in this material and controlled under the "Foreign Exchange and Foreign Trade Law" is to be exported or taken out of Japan.
- (2) The technical information described in this material is limited to showing representative characteristics and applied circuit examples of the products. It does not constitute the warranting of industrial property, the granting of relative rights, or the granting of any license.
- (3) The products described in this material are intended to be used for standard applications or general electronic equipment (such as office equipment, communications equipment, measuring instruments and household appliances).
Consult our sales staff in advance for information on the following applications:
 - Special applications (such as for airplanes, aerospace, automobiles, traffic control equipment, combustion equipment, life support systems and safety devices) in which exceptional quality and reliability are required, or if the failure or malfunction of the products may directly jeopardize life or harm the human body.
 - Any applications other than the standard applications intended.
- (4) The products and product specifications described in this material are subject to change without notice for reasons of modification and/or improvement. At the final stage of your design, purchasing, or use of the products, therefore, ask for the most up-to-date Product Standards in advance to make sure that the latest specifications satisfy your requirements.
- (5) When designing your equipment, comply with the guaranteed values, in particular those of maximum rating, the range of operating power supply voltage and heat radiation characteristics. Otherwise, we will not be liable for any defect which may arise later in your equipment.
Even when the products are used within the guaranteed values, redundant design is recommended, so that such equipment may not violate relevant laws or regulations because of the function of our products.
- (6) When using products for which dry packing is required, observe the conditions (including shelf life and after-unpacking standby time) agreed upon when specification sheets are individually exchanged.
- (7) No part of this material may be reprinted or reproduced by any means without written permission from our company.

Please read the following notes before using the datasheets

- A. These materials are intended as a reference to assist customers with the selection of Panasonic semiconductor products best suited to their applications.
Due to modification or other reasons, any information contained in this material, such as available product types, technical data, and so on, is subject to change without notice.
Customers are advised to contact our semiconductor sales office and obtain the latest information before starting precise technical research and/or purchasing activities.
- B. Panasonic is endeavoring to continually improve the quality and reliability of these materials but there is always the possibility that further rectifications will be required in the future. Therefore, Panasonic will not assume any liability for any damages arising from any errors etc. that may appear in this material.
- C. These materials are solely intended for a customer's individual use.
Therefore, without the prior written approval of Panasonic, any other use such as reproducing, selling, or distributing this material to a third party, via the Internet or in any other way, is prohibited.



LittleDiode supplies new, hard to find or obsolete electronic components and semiconductors all over the world.

With over two million different components listed you are sure to find the part you need.

Feel free to visit us today at our online store:

LittleDiode.com

Looking forward to providing you with the best possible service.