

Stepping Motor Drive IC AN8495SB

■ Overview

AN8495SB is a stepping-motor-driving IC, created by using a D-MOS process, and provides a maximum output of 30V at 1.5A. By the PWM drive and 2-bit constant-current-chopping-drive method, the winding 1-2 phase drive is possible.

■ Features

- 4-phase input (W1-2 phase excitation)
- 2-bit current level switching.
- Built-in noise canceler.
- Built-in phase-change thru-current protection function.
- Built-in flywheel diode

■ Applications

- Printer ● FAX ● PPC

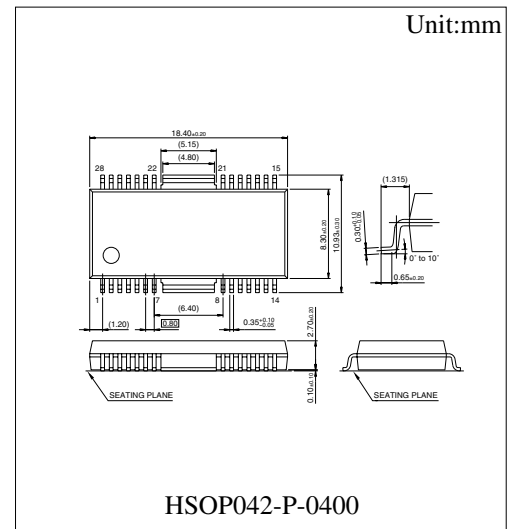

† The products and specifications are subject to change without any notice. Please ask for the latest product standards to guarantee the satisfaction of your product requirements.

■ Block Diagram

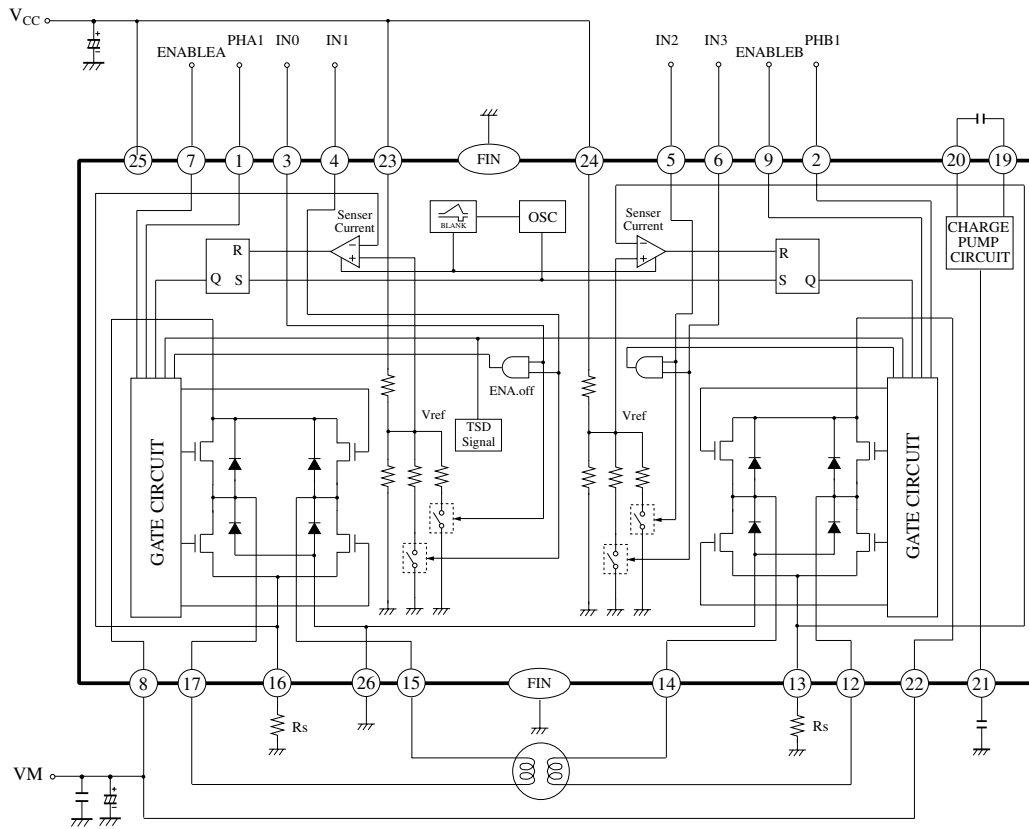

* A voltage is applied externally to Terminals PHA1, PHB1, IN0 to 3, ENABLEA, ENABLEB, VREFA and VREFV, and may cause an overcurrent. To protect the device from overcurrent, insert an overcurrent protective resistor (1KΩ or over).

■ Pin Description

Pin No.	Function	Pin No.	Function		
1	PHA1	A phase changeover terminal	16	RCSA	A phase current detector
2	PHB1	B phase changeover terminal	17	AOUT1	Motor drive A phase output 1
3	IN0	A phase output torque control 1	18	N.C	—
4	IN1	A phase output torque control 2	19	BC1	Capacitor for charge pump circuit 1
5	IN2	B phase output torque control 1	20	BC2	Capacitor for charge pump circuit 2
6	IN3	B phase output torque control 2	21	VPUMP	Charge pump circuit output
7	ENABLEA	A phase start/stop signal input	22	VM2	Supply terminal for Motor 2
8	VM1	Supply terminal for Motor 1	23	VREFA	A phase torque ref. voltage input
9	ENABLEB	B phase start/stop signal input	24	VREFB	B phase torque ref. voltage input
10	N.C	—	25	VCC	Supply terminal
11	N.C	—	26	GND	Signal GND
12	BOUT2	Motor drive B phase output 2	27	N.C	—
13	RCSB	B phase current detector	28	N.C	—
14	BOUT1	Motor drive B phase output 1	FIN	GND	Signal GND
15	AOUT2	Motor drive A phase output 2			

■ Absolute Maximum Ratings

Parameter	Symbol	Rating	Unit	Note
Storage temperature	T_{stg}	-55 to +150	°C	1
Operating ambient temperature	T_{opr}	-20 to +70	°C	1
Supply voltage	V_{CC}	7.0	V	
Supply current	I_{CC}	30	mA	
Power dissipation	P_D	1.04	W	2
Motor supply voltage	V_{M1}/V_{M2}	30	V	Pin=8,22
Output voltage	V_{OUT}	30	V	Pin=12,14 15,17
Motor drive current	I_{OUT}	±1.5	A	
Flyhoile diode current	I_f	1.5	A	
Charge pump circuit voltage	V_{PUMP}	40	V	Pin=21

Note 1) $T_a=25^{\circ}\text{C}$ except storage temperature and operating ambient temperature.

Note 2) Power dissipation shows the value of only package at $T_a=70^{\circ}\text{C}$.

■ Recommended Operating Range

Operating supply voltage range	V_{CC}	4.75 V to 5.25 V
	V_M	18.0 V to 28.0 V

■ Electrical Characteristics ($T_a = 25^{\circ}\text{C} \pm 2^{\circ}\text{C}, V_{CC} = 5.0\text{ V}, V_M = 24\text{ V}$)

Parameter	Symbol	Condition	min	typ	max	Unit
Power block						
Output saturation voltage H	V_{OH}	$I = -1.0\text{ A}$	$V_M-0.75$	$V_M-0.5$	—	V
Output saturation voltage L	V_{OL}	$I = 1.0\text{ A}$	—	0.65	0.98	V
Flywheel diode forward voltage	V_{DI}	$I = 1.0\text{ A}$	0.5	1.0	1.5	V
Output leak current 1	I_{LEAK1}	$V_{OUT} = 30\text{ V}, V_{RCS} = 0\text{ V}$	—	10	50	μA
Circuit current						
Supply current (2-circuit ON)	I_{CC}	ENABLEA=ENABLEB= 0 V	—	5	9.5	mA
I/O block						
IN “H” input voltage	V_{INH}		2.0	—	V_{CC}	V
IN “L” input voltage	V_{INL}		GND	—	0.6	V
IN “H” input current	I_{INH}	$V_{IN} = 5\text{ V}$	-10	0	10	μA
IN “L” input current	I_{INL}	$V_{IN} = 0\text{ V}$	-80	-40	-20	μA
PHA1,PHB1 “H” input voltage	$V_{PHAH/PHBH}$		2.0	—	V_{CC}	V
PHA1,PHB1 “L” input voltage	$V_{PHAL/PHBL}$		GND	—	0.6	V
PHA1,PHB1 “H” input current	$I_{PHAH/PHBH}$	PHA1 = PHB1 = 5 V	-10	0	10	μA
PHA1,PHB1 “L” input current	$I_{PHAL/PHBL}$	PHA1 = PHB1 = 0 V	-150	-100	-50	μA

■ Electrical Characteristics (Ta = 25 °C ± 2 °C, V_{CC} = 5.0 V, V_M = 24 V)

Parameter	Symbol	Condition	min	typ	max	Unit
I/O block (continue)						
ENABLEA,ENABLEB “H” input voltage	V _{ENABLEAH} V _{ENABLEBH}		2.0	—	V _{CC}	V
ENABLEA,ENABLEB “L” input voltage	V _{ENABLEAL} V _{ENABLEBL}		GND	—	0.6	V
ENABLEA,ENABLEB “H” input current	I _{ENABLEAH} I _{ENABLEBH}	ENABLEA = ENABLEB = 5 V	-10	0	10	μA
ENABLEA,ENABLEB “L” input current	I _{ENABLEAL} I _{ENABLEBL}	ENABLEA = ENABLEB = 0 V	-15	-2	15	μA
Control block						
Input bias current	I _{REFA/REFB}	V _{REFA} = V _{REFB} = 5 V	67	90	150	μA
PWM frequency	f _{PWM}		50.2	67	83.8	kHz
Pulse blanking time	T _B	V _{REFA} = V _{REFB} = 0 V	1.0	2.0	3.0	μs
Comparator threshold H(100%)	V _{T_H}	IN0=IN1=0 V,IN2=IN3=0 V	0.479	0.503	0.528	V
Comparator threshold C(67%)	V _{T_C}	IN0=5V,IN1=0V,IN2=5V,IN3=0V	0.305	0.330	0.356	V
Comparator threshold L(33%)	V _{T_L}	IN0=0V,IN1=5V,IN2=0V,IN3=5V	0.151	0.167	0.185	V

■ Electrical Characteristics (Reference Data for Designing)

Parameter	Symbol	Condition	min	typ	max	Unit
Output block						
Output slew rate 1	V _{T_r}	Rise time	—	240	—	V/μs
Output slew rate 2	V _{T_f}	Fall time	—	-240	—	V/μs
Dead time	T _D		—	1.5	—	μs
Thermal shutdown						
Thermal shutdown temperature	TSD _{on}		—	150	—	°C
Thermal shutdown hysteresis	ΔTSD		—	36	—	°C

■ Package Dissipation

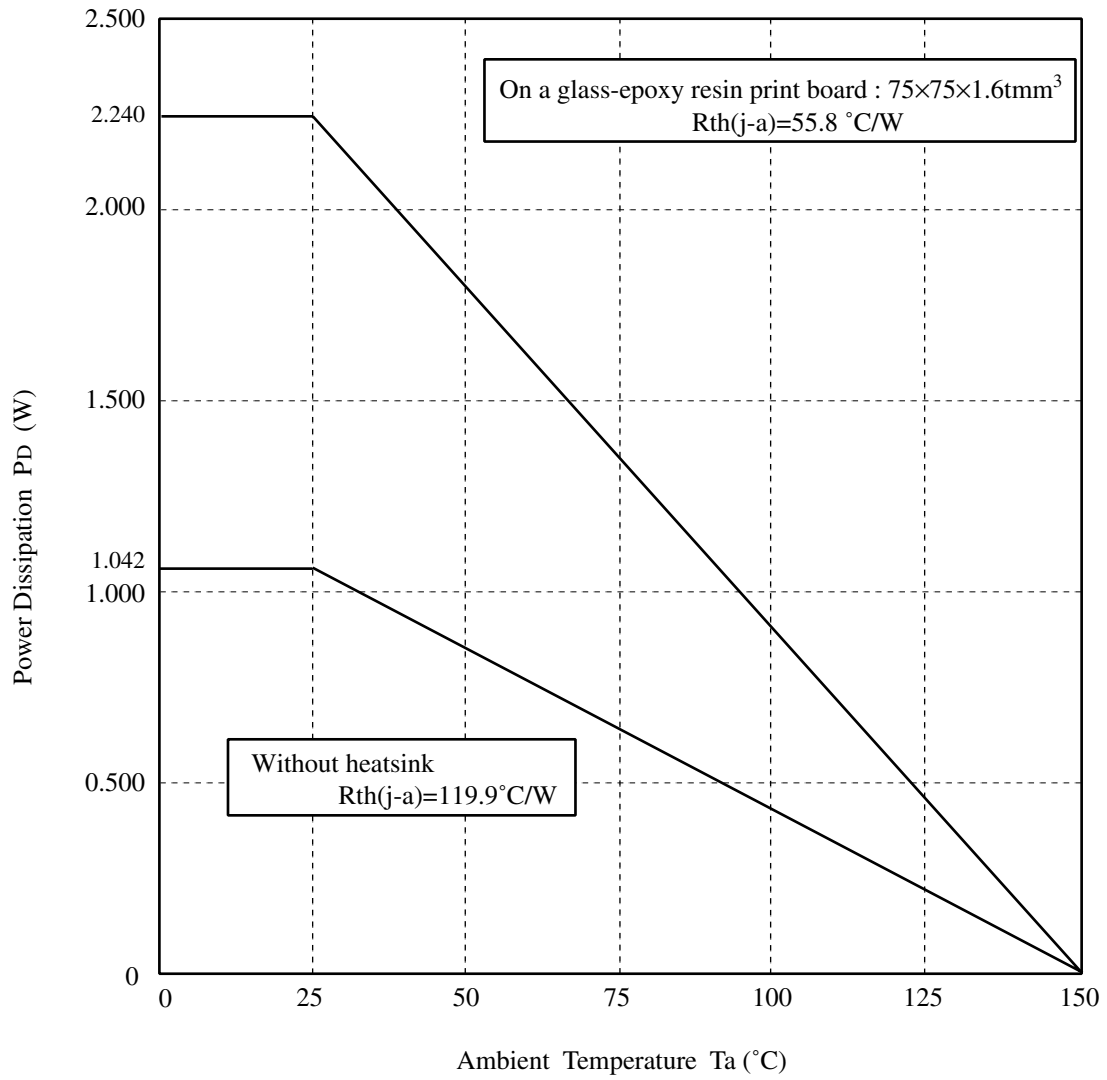

■ Logic Table

ENABLEA/B	PHA1/PHB1	AOUT1/BOUT1	AOUT2/BOUT2
L	H	H	L
L	L	L	H
H	-	OFF	OFF

IN0/IN2	IN1/IN3	Output current
L	L	$V_{ref}/(10 \times R_s) = I_{out}$
H	L	$V_{ref}/(15 \times R_s) = I_{out} \times 2/3$
L	H	$V_{ref}/(30 \times R_s) = I_{out} \times 1/3$
H	H	0

■ Full Step (4 step sequence)

(IN0 to IN3 = const.)

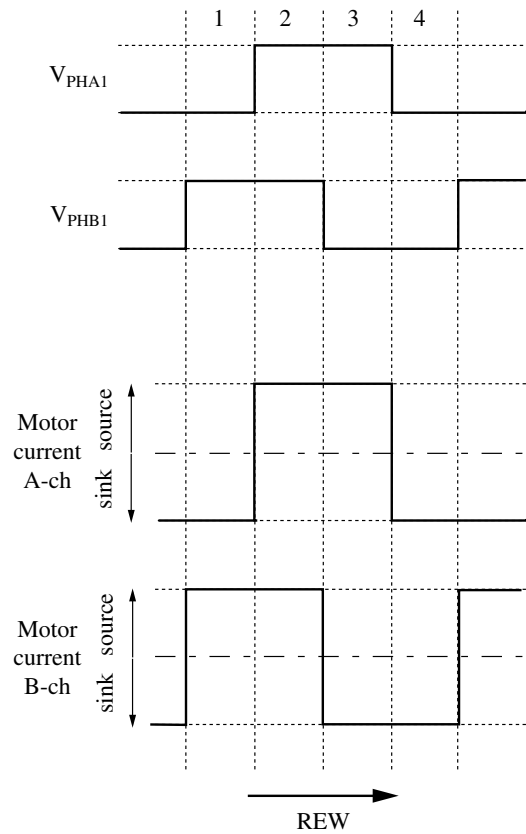
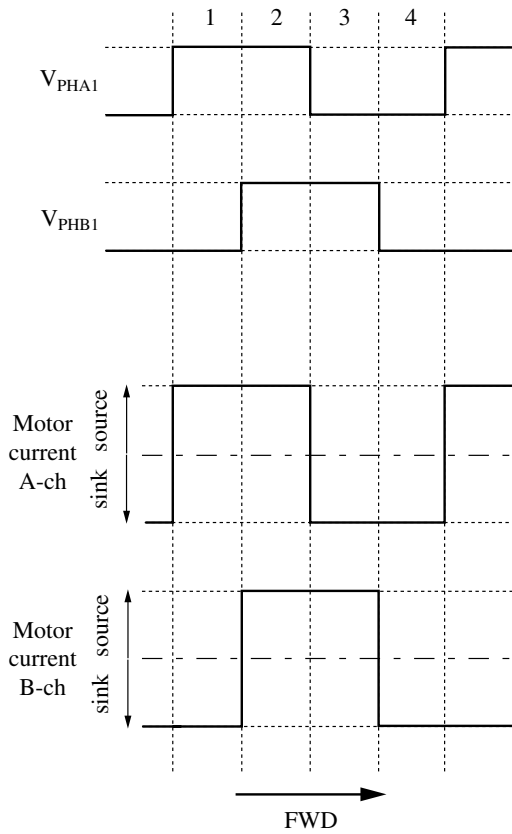

■ Half Step (8 step sequence)
 (EX.)

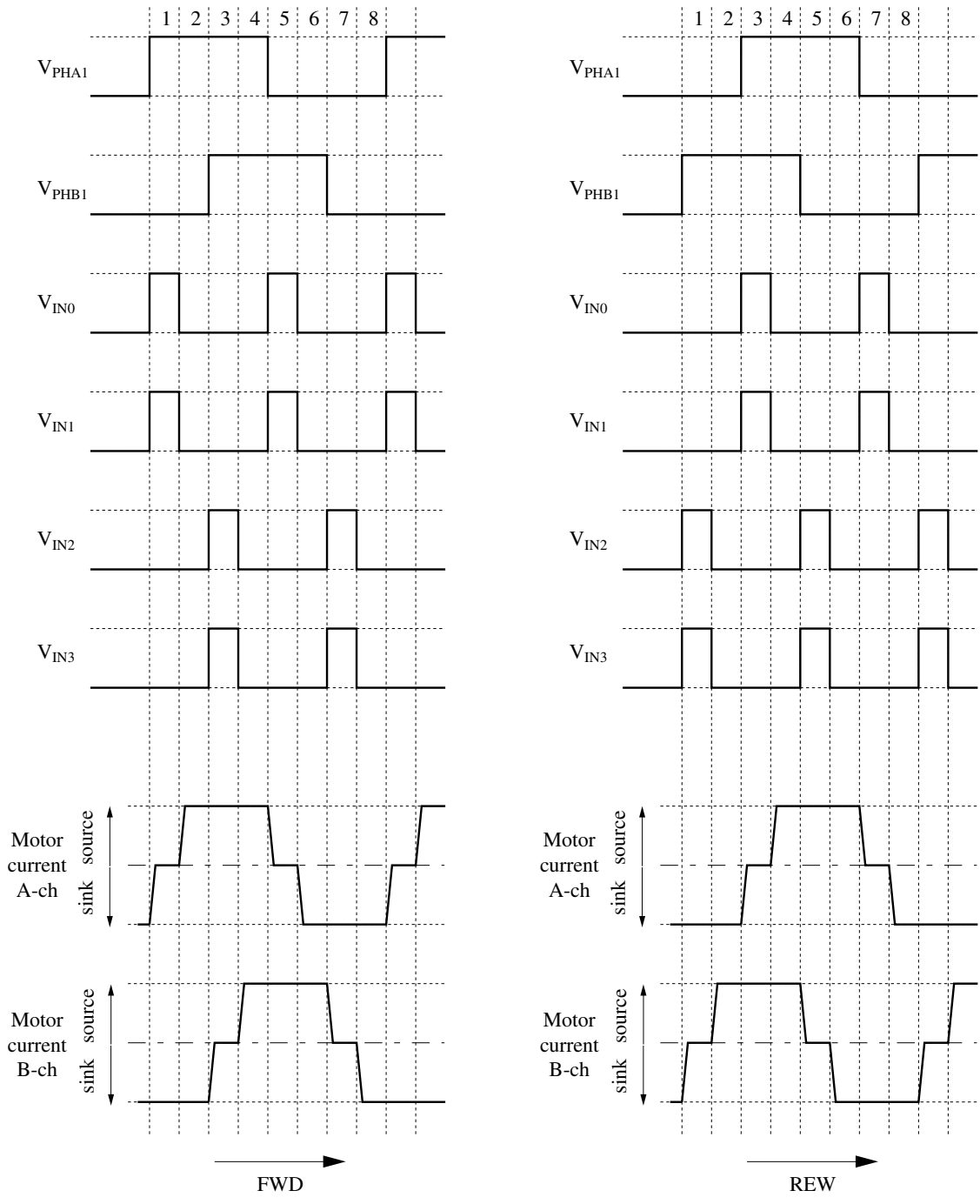

■ 1-2 Phase Excitation (8 step sequence)

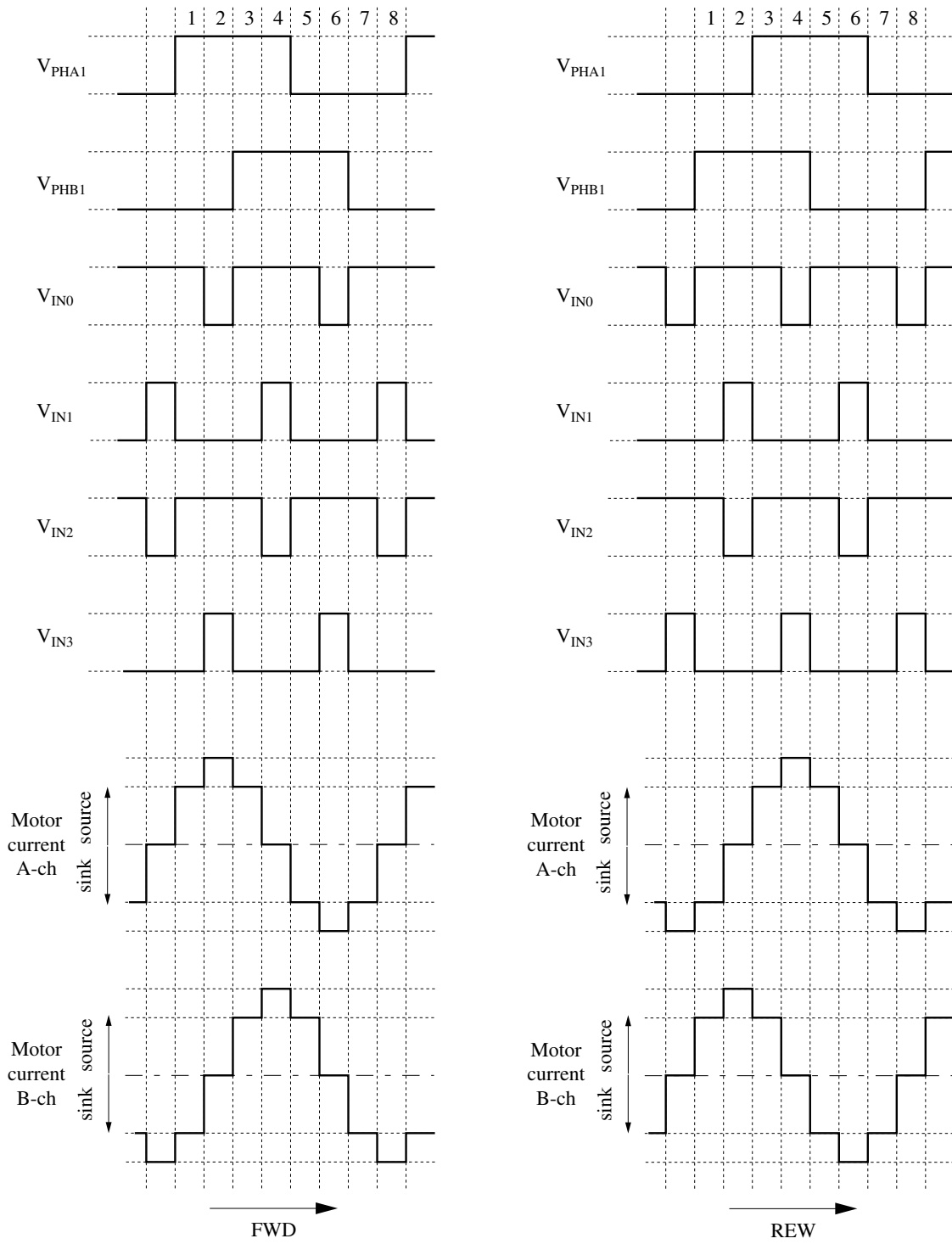

■ W1-2 Phase Excitation (16 step sequence)

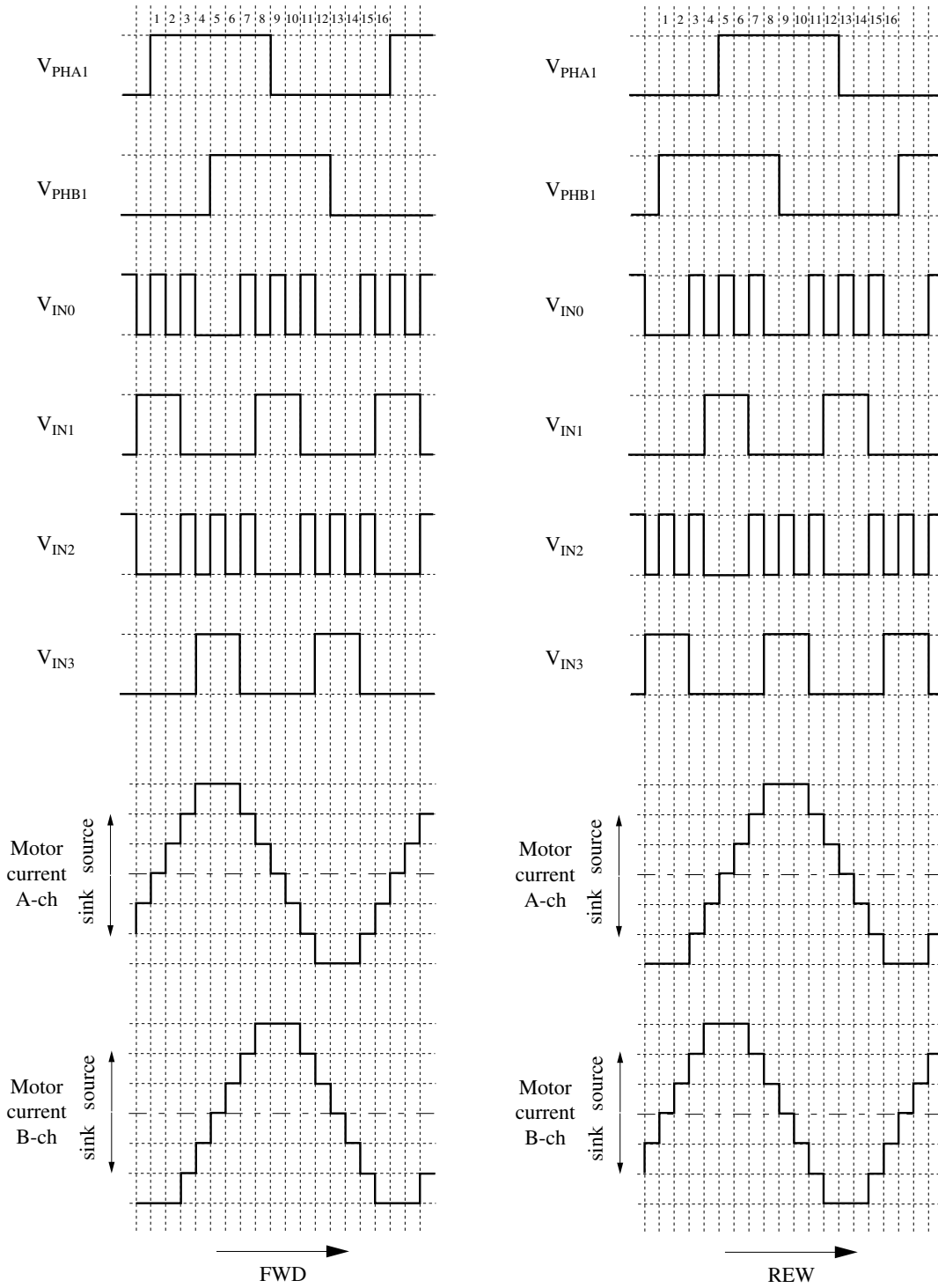

Request for your special attention and precautions in using the technical information and semiconductors described in this material

- (1) An export permit needs to be obtained from the competent authorities of the Japanese Government if any of the products or technologies described in this material and controlled under the "Foreign Exchange and Foreign Trade Law" is to be exported or taken out of Japan.
- (2) The technical information described in this material is limited to showing representative characteristics and applied circuit examples of the products. It does not constitute the warranting of industrial property, the granting of relative rights, or the granting of any license.
- (3) The products described in this material are intended to be used for standard applications or general electronic equipment (such as office equipment, communications equipment, measuring instruments and household appliances).
Consult our sales staff in advance for information on the following applications:
 - Special applications (such as for airplanes, aerospace, automobiles, traffic control equipment, combustion equipment, life support systems and safety devices) in which exceptional quality and reliability are required, or if the failure or malfunction of the products may directly jeopardize life or harm the human body.
 - Any applications other than the standard applications intended.
- (4) The products and product specifications described in this material are subject to change without notice for reasons of modification and/or improvement. At the final stage of your design, purchasing, or use of the products, therefore, ask for the most up-to-date Product Standards in advance to make sure that the latest specifications satisfy your requirements.
- (5) When designing your equipment, comply with the guaranteed values, in particular those of maximum rating, the range of operating power supply voltage and heat radiation characteristics. Otherwise, we will not be liable for any defect which may arise later in your equipment.
Even when the products are used within the guaranteed values, redundant design is recommended, so that such equipment may not violate relevant laws or regulations because of the function of our products.
- (6) When using products for which dry packing is required, observe the conditions (including shelf life and after-unpacking standby time) agreed upon when specification sheets are individually exchanged.
- (7) No part of this material may be reprinted or reproduced by any means without written permission from our company.

Please read the following notes before using the datasheets

- A. These materials are intended as a reference to assist customers with the selection of Panasonic semiconductor products best suited to their applications.
Due to modification or other reasons, any information contained in this material, such as available product types, technical data, and so on, is subject to change without notice.
Customers are advised to contact our semiconductor sales office and obtain the latest information before starting precise technical research and/or purchasing activities.
- B. Panasonic is endeavoring to continually improve the quality and reliability of these materials but there is always the possibility that further rectifications will be required in the future. Therefore, Panasonic will not assume any liability for any damages arising from any errors etc. that may appear in this material.
- C. These materials are solely intended for a customer's individual use.
Therefore, without the prior written approval of Panasonic, any other use such as reproducing, selling, or distributing this material to a third party, via the Internet or in any other way, is prohibited.

This datasheet has been downloaded from:

www.DatasheetCatalog.com

Datasheets for electronic components.



LittleDiode supplies new, hard to find or obsolete electronic components and semiconductors all over the world.

With over two million different components listed you are sure to find the part you need.

Feel free to visit us today at our online store:

LittleDiode.com

Looking forward to providing you with the best possible service.