

# AN8814SB

## 4-channel driver IC for optical disk drive

### ■ Overview

The AN8814SB is a BTL system 4-channel driver and is encapsulated in the SMD package which excels in heat radiation characteristic.

### ■ Features

- Wide output dynamic range regardless of reference voltage of the system
- Driver I/O gain setting is possible with an additional external resistor
- 3.3 V supply voltage is available due to an external PNP-tr.
- Additional OP-amp. built-in

### ■ Applications

- MD, CD/CD-ROM drive
- DVD/DVD-ROM drive

### ■ Block Diagram

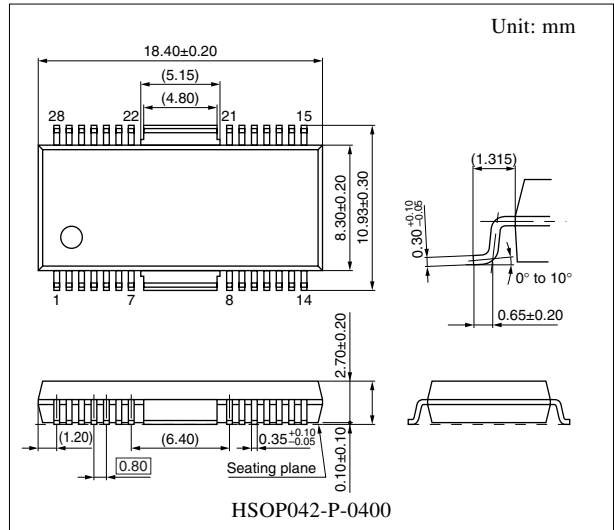
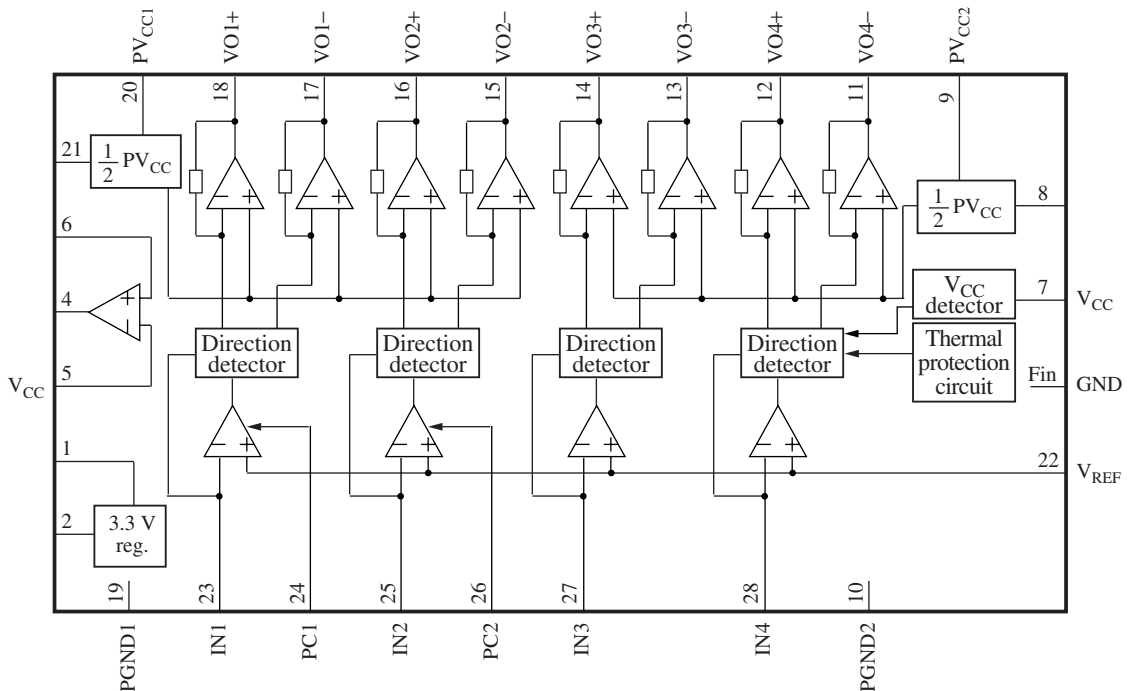

Note) The package of this product will be changed to lead-free type (HSOP042-P-0400D). See the new package dimensions section later of this datasheet.

## ■ Pin Descriptions

Pin No.	Description	Pin No.	Description
1	Base control pin for an external transistor of 3.3 V regulator	15	Motor driver-2 reverse rotation output pin
		16	Motor driver-2 forward rotation output pin
2	3.3 V regulator output monitor pin	17	Motor driver-1 reverse rotation output pin
3	N.C. pin	18	Motor driver-1 forward rotation output pin
4	Op-amp. output pin	19	Driver GND pin 1
5	Op-amp. inverted input pin	20	Driver power supply pin 1
6	Op-amp. non-inverted input pin	21	1/2 PV <sub>CC</sub> output pin 1
7	Power supply pin	22	V <sub>REF</sub> input pin
8	1/2 PV <sub>CC</sub> output pin 2	23	Motor driver-1 input pin
9	Driver power supply pin 2	24	PC (power cut) input pin 1
10	Driver GND pin 2	25	Motor driver-2 input pin
11	Motor driver-4 reverse rotation output pin	26	PC (power cut) input pin 2
12	Motor driver-4 forward rotation output pin	27	Motor driver-3 input pin
13	Motor driver-3 reverse rotation output pin	28	Motor driver-4 input pin
14	Motor driver-3 forward rotation output pin	Fin	GND pin

## ■ Absolute Maximum Ratings

Parameter	Symbol	Rating	Unit
Supply voltage	SV <sub>CC</sub>	17	V
Supply current	I <sub>CC</sub>	—	mA
Power dissipation *2	P <sub>D</sub>	542	mW
Operating ambient temperature *1	T <sub>opr</sub>	-30 to +85	°C
Storage temperature *1	T <sub>stg</sub>	-55 to +150	°C

Note) \*1: Except for the operating ambient temperature and storage temperature, all ratings are for T<sub>a</sub> = 25°C.

\*2: T<sub>a</sub> = 85°C.

Referring to "■ Application Circuit Example", following the allowable power dissipation characteristic curve of "■ Application Notes".

## ■ Recommended Operating Range

Parameter	Symbol	Range	Unit
Supply voltage	SV <sub>CC</sub> , PV <sub>CC1</sub> , PV <sub>CC2</sub>	4.0 to 14	V

### ■ Electrical Characteristics at $T_a = 25^\circ\text{C}$

Parameter	Symbol	Conditions	Min	Typ	Max	Unit
Current consumption with no load	$I_{\text{TOT}}$	$V_{\text{CC}} = 5\text{ V}$	5	10	15	mA
<b>Motor driver 1 to motor driver 4</b>						
Input offset voltage	$V_{\text{IOF}}$	$V_{\text{CC}} = 5\text{ V}$ , $V_{\text{PC1}} = V_{\text{PC2}} = 0\text{ V}$ , $R_{\text{L1}}$ to $R_{\text{L4}} = 8\text{ k}\Omega$ , $R_1$ to $R_4 = 10\text{ k}\Omega$	-10	0	10	mV
Output offset voltage	$V_{\text{OOF}}$	$V_{\text{CC}} = 5\text{ V}$ , $V_{\text{PC1}} = V_{\text{PC2}} = 0\text{ V}$ , $R_{\text{L1}}$ to $R_{\text{L4}} = 8\text{ k}\Omega$ , $R_1$ to $R_4 = 10\text{ k}\Omega$	-50	0	50	mV
Gain	G	$V_{\text{CC}} = 5\text{ V}$ , $V_{\text{PC1}} = V_{\text{PC2}} = 0\text{ V}$ , $R_{\text{L1}}$ to $R_{\text{L4}} = 8\text{ k}\Omega$ , $R_1$ to $R_4 = 10\text{ k}\Omega$	18.0	20.0	22.0	dB
Maximum output amplitude (+)	$V_{\text{L+}}$	$V_{\text{CC}} = 5\text{ V}$ , $V_{\text{PC1}} = V_{\text{PC2}} = 0\text{ V}$ , $R_{\text{L1}}$ to $R_{\text{L4}} = 8\text{ k}\Omega$ , $R_1$ to $R_4 = 10\text{ k}\Omega$	2.4	2.7	—	V
Maximum output amplitude (-)	$V_{\text{L-}}$	$V_{\text{CC}} = 5\text{ V}$ , $V_{\text{PC1}} = V_{\text{PC2}} = 0\text{ V}$ , $R_{\text{L1}}$ to $R_{\text{L4}} = 8\text{ k}\Omega$ , $R_1$ to $R_4 = 10\text{ k}\Omega$	—	-2.7	-2.4	V
<b>Motor driver 1</b>						
High-level threshold voltage	$V_{\text{PCH1}}$	$V_{\text{CC}} = 5\text{ V}$ , $R_{\text{L1}} = 8\text{ }\Omega$ , $R_1 = 10\text{ k}\Omega$	2.0	—	—	V
Low-level threshold voltage	$V_{\text{PCL1}}$	$V_{\text{CC}} = 5\text{ V}$ , $R_{\text{L1}} = 8\text{ }\Omega$ , $R_1 = 10\text{ k}\Omega$	—	—	0.5	V
<b>Motor driver 2</b>						
High-level threshold voltage	$V_{\text{PCH2}}$	$V_{\text{CC}} = 5\text{ V}$ , $R_{\text{L2}} = 8\text{ }\Omega$ , $R_2 = 10\text{ k}\Omega$	2.0	—	—	V
Low-level threshold voltage	$V_{\text{PCL2}}$	$V_{\text{CC}} = 5\text{ V}$ , $R_{\text{L2}} = 8\text{ }\Omega$ , $R_2 = 10\text{ k}\Omega$	—	—	0.5	V
<b>Reset circuit</b>						
Reset operation release supply voltage	$V_{\text{RST}}$	$I_{\text{IN}} = 10\text{ }\mu\text{A}$ , $R_1$ to $R_4 = 10\text{ k}\Omega$	2.1	2.3	2.5	V
<b>3.3 V regulator</b>						
Output voltage	$V_{\text{REG}}$	$V_{\text{CC}} = 5\text{ V}$	3.1	3.3	3.5	V
Output load fluctuation	$\Delta V_{\text{R}}$	$V_{\text{CC}} = 5\text{ V}$	-50	0	50	mV
Supply voltage fluctuation	$\Delta V_{\text{V}}$	$V_{\text{CC}} = 5\text{ V}/12\text{ V}$	-5	0	5	mV
<b>Op-amp.</b>						
Input offset voltage	$V_{\text{OF}}$	$V_{\text{CC}} = 5\text{ V}$	-10	0	10	mV
Input bias current	$I_{\text{BOP}}$	$V_{\text{CC}} = 5\text{ V}$	—	150	500	nA
High-level output voltage	$V_{\text{OH}}$	$V_{\text{CC}} = 5\text{ V}$	4.0	—	—	V
Low-level output voltage	$V_{\text{OL}}$	$V_{\text{CC}} = 5\text{ V}$	—	—	1.5	V
Output driving current sink	$I_{\text{SIN}}$	$V_{\text{CC}} = 5\text{ V}$	2.0	—	—	mA
Output driving current source	$I_{\text{SOU}}$	$V_{\text{CC}} = 5\text{ V}$	2.0	—	—	mA

■ Electrical Characteristics at  $T_a = 25^\circ\text{C}$  (continued)

• Design reference data

Note) The characteristics listed below are theoretical values based on the IC design and are not guaranteed.

Parameter	Symbol	Conditions	Min	Typ	Max	Unit
Thermal protection circuit						
Operating temperature equilibrium value	$T_{\text{THD}}$		—	180	—	$^\circ\text{C}$
Operating temperature hysteresis width	$\Delta T_{\text{THD}}$		—	45	—	$^\circ\text{C}$

■ Usage Notes

1. Avoid the short-circuits between output and  $V_{\text{CC}}$ , and between output pin and GND. Otherwise, the IC is likely to break down or emit smoke.
2. An appropriate prior study should be done for use of dip soldering.

■ Application Notes

•  $P_D - T_a$  curves of HSOP042-P-0400

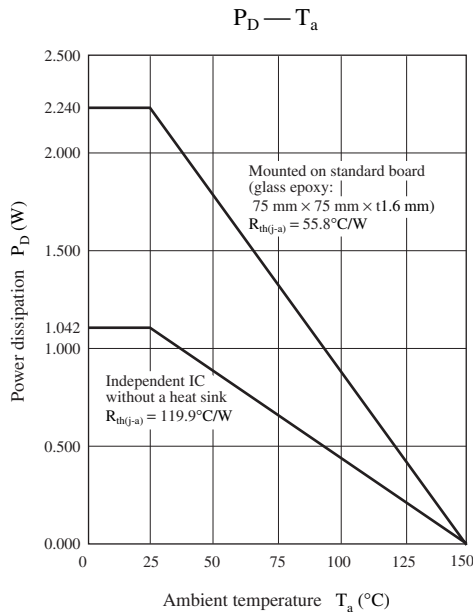

■ Application Circuit Example

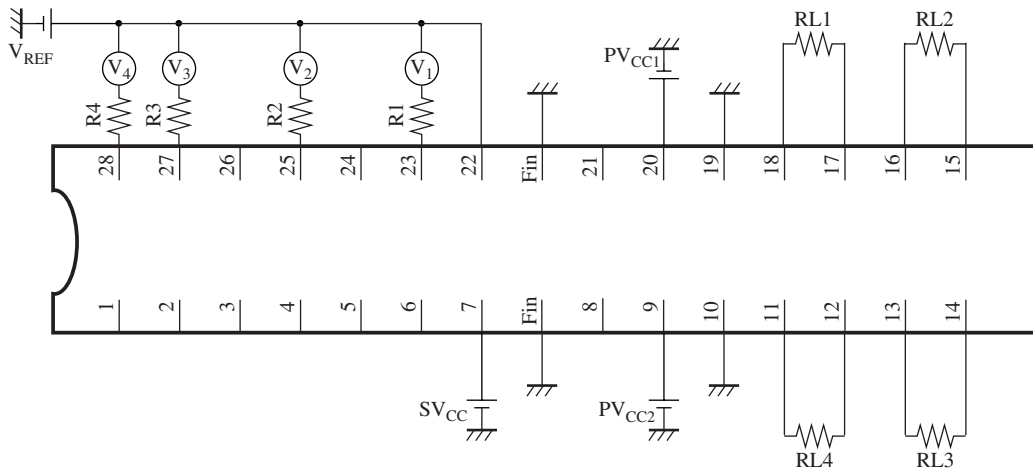

When the AN8814SB is use, take into account the following cautions and follow the power dissipation characteristic curve.

1. Load current  $I_{P1}$  flowing into load  $RL1$ ,  $RL2$  is supplied through pin 20.

$$I_{P1} = \frac{|V_{18} - V_{17}|}{R_{L1}} + \frac{|V_{16} - V_{15}|}{R_{L2}}$$

2. Load current  $I_{P2}$  flowing into load  $RL3$ ,  $RL4$  is supplied through pin 9.

$$I_{P2} = \frac{|V_{14} - V_{13}|}{R_{L3}} + \frac{|V_{12} - V_{11}|}{R_{L4}}$$

3. Dissipation increase ( $\Delta P_D$ ) inside the IC (power output stage) caused by loads  $RL1$ ,  $RL2$ ,  $RL3$  and  $RL4$  is as follows:

$$\begin{aligned} \Delta P_D &= (PV_{CC1} - |V_{18} - V_{17}|) \times \frac{|V_{18} - V_{17}|}{R_{L1}} + (PV_{CC1} - |V_{16} - V_{15}|) \times \frac{|V_{16} - V_{15}|}{R_{L2}} \\ &= (PV_{CC2} - |V_{14} - V_{13}|) \times \frac{|V_{14} - V_{13}|}{R_{L3}} + (PV_{CC2} - |V_{12} - V_{11}|) \times \frac{|V_{12} - V_{11}|}{R_{L4}} \end{aligned}$$

4. Dissipation increase ( $\Delta P_S$ ) inside the IC (signal block supplied from pin 7) caused by loads  $RL1$ ,  $RL2$ ,  $RL3$  and  $RL4$  comes roughly as follows:

$$\begin{aligned} \Delta P_S &= 3 \times \left\{ \frac{V_1}{R_1} \times (2 \times SV_{CC} + |V_{18} - V_{17}|) + \frac{V_2}{R_2} \times (2 \times SV_{CC} + |V_{16} - V_{15}|) \right. \\ &\quad \left. + \frac{V_3}{R_3} \times (2 \times SV_{CC} + |V_{14} - V_{13}|) + \frac{V_4}{R_4} \times (2 \times SV_{CC} + |V_{12} - V_{11}|) \right\} \end{aligned}$$

5. Dissipation increase in a driver operating mode is  $\Delta P_D + \Delta P_S$ .

6. Allowable power dissipation without load ( $P_{D1}$ ) can be found as follows:

$$P_{D1} = SV_{CC} \times I_{SVCC} + PV_{CC1} \times I_{PVCC1} + PV_{CC2} \times I_{PVCC2}$$

7. Allowable power dissipation in a load operating mode ( $P_D$ ) comes roughly as follows:

$$P_D = P_{D1} + \Delta P_D + \Delta P_S$$

■ New Package Dimensions (Unit: mm)

- HSOP042-P-0400D (Lead-free package)

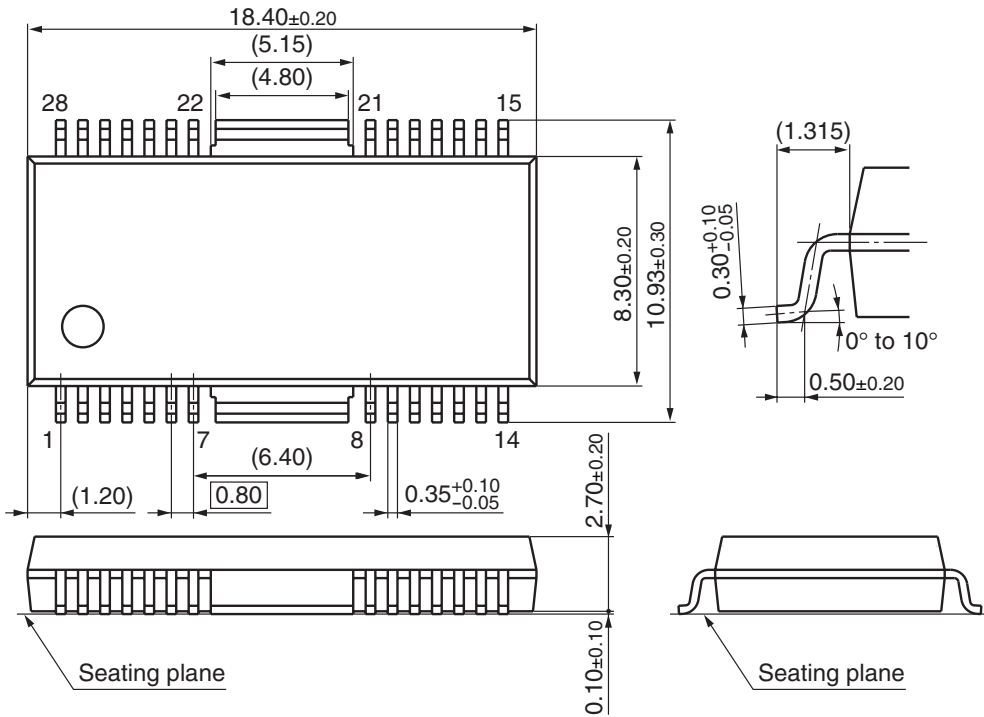

## Request for your special attention and precautions in using the technical information and semiconductors described in this material

- (1) An export permit needs to be obtained from the competent authorities of the Japanese Government if any of the products or technologies described in this material and controlled under the "Foreign Exchange and Foreign Trade Law" is to be exported or taken out of Japan.
- (2) The technical information described in this material is limited to showing representative characteristics and applied circuit examples of the products. It does not constitute the warranting of industrial property, the granting of relative rights, or the granting of any license.
- (3) The products described in this material are intended to be used for standard applications or general electronic equipment (such as office equipment, communications equipment, measuring instruments and household appliances).  
Consult our sales staff in advance for information on the following applications:
  - Special applications (such as for airplanes, aerospace, automobiles, traffic control equipment, combustion equipment, life support systems and safety devices) in which exceptional quality and reliability are required, or if the failure or malfunction of the products may directly jeopardize life or harm the human body.
  - Any applications other than the standard applications intended.
- (4) The products and product specifications described in this material are subject to change without notice for reasons of modification and/or improvement. At the final stage of your design, purchasing, or use of the products, therefore, ask for the most up-to-date Product Standards in advance to make sure that the latest specifications satisfy your requirements.
- (5) When designing your equipment, comply with the guaranteed values, in particular those of maximum rating, the range of operating power supply voltage and heat radiation characteristics. Otherwise, we will not be liable for any defect which may arise later in your equipment.  
Even when the products are used within the guaranteed values, redundant design is recommended, so that such equipment may not violate relevant laws or regulations because of the function of our products.
- (6) When using products for which dry packing is required, observe the conditions (including shelf life and after-unpacking standby time) agreed upon when specification sheets are individually exchanged.
- (7) No part of this material may be reprinted or reproduced by any means without written permission from our company.

## Please read the following notes before using the datasheets

- A. These materials are intended as a reference to assist customers with the selection of Panasonic semiconductor products best suited to their applications.  
Due to modification or other reasons, any information contained in this material, such as available product types, technical data, and so on, is subject to change without notice.  
Customers are advised to contact our semiconductor sales office and obtain the latest information before starting precise technical research and/or purchasing activities.
- B. Panasonic is endeavoring to continually improve the quality and reliability of these materials but there is always the possibility that further rectifications will be required in the future. Therefore, Panasonic will not assume any liability for any damages arising from any errors etc. that may appear in this material.
- C. These materials are solely intended for a customer's individual use.  
Therefore, without the prior written approval of Panasonic, any other use such as reproducing, selling, or distributing this material to a third party, via the Internet or in any other way, is prohibited.



LittleDiode supplies new, hard to find or obsolete electronic components and semiconductors all over the world.

With over two million different components listed you are sure to find the part you need.

Feel free to visit us today at our online store:

[LittleDiode.com](http://LittleDiode.com)

Looking forward to providing you with the best possible service.