

# AN8849SB

## Head amplifier IC for CD-ROM drive (for 24 times speed or more)

### ■ Overview

The AN8849SB is a head amplifier IC for digital servo. It can configure an efficient CD-ROM system in combination with the MN662752, and allows a full-automatic adjustment of tracking balance-gain-offset and focus balance-gain-offset with fewer external parts.

Built-in functions are a variable equalizer, wide band RF amp. and AGC which meet CAV playback with 24 times speed or more.

### ■ Features

- Variable equalizer which meets CAV playback with 24 times speed or more CAV playback.
- Wide band RF amp. and AGC ( $f_c = 20$  MHz or more (-3 dB))
- Balance adjustment function built-in  
Focus error amp./tracking error amp.
- CD-RW playback compatible.  
Variable gain  
Focus error amp./tracking error amp.  
(to +16.9 dB)
- OFTR/BDO detection
- APC amp.

### ■ Applications

- CD/CD-ROM drive

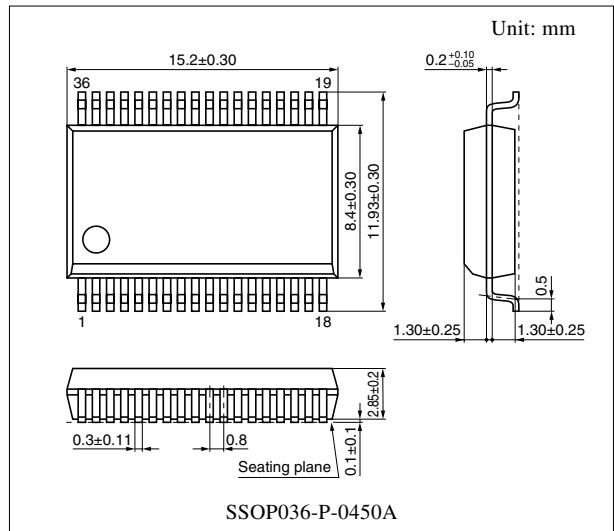

Note) The package of this product will be changed to lead-free type (SSOP036-P-0450C). See the new package dimensions section later of this datasheet.

■ Block Diagram

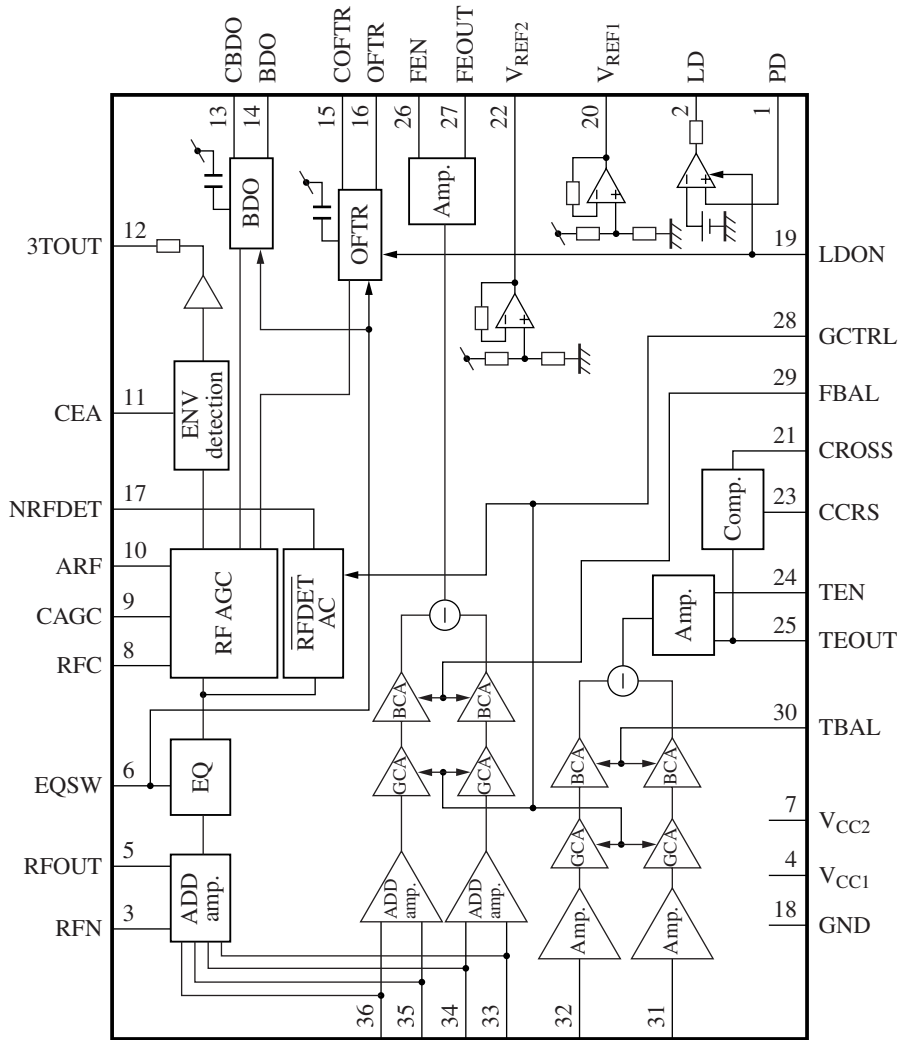

## ■ Pin Descriptions

Pin No.	Description	Pin No.	Description
1	APC amp. input pin	18	GND pin
2	APC amp. output pin	19	APC & masking control pin
3	RF addition amp. inverted input pin	20	V <sub>REF1</sub> output pin
4	Power supply pin 1	21	CROSS output pin
5	RF addition amp. output pin	22	V <sub>REF2</sub> output pin
6	EQ characteristics control pin	23	Capacitor connection pin for CROSS
7	Power supply pin 2	24	TE amp. inverted input pin
8	Capacitor connection pin for HPF of AGC input	25	TE amp. output pin
9	AGC loop filter connection pin	26	FE amp. inverted input pin
10	AGC output pin	27	FE amp. output pin
11	Capacitor connection pin for HPF amp.	28	GCTRL pin
12	3TENV output pin	29	FBAL control pin
13	Capacitor connection pin for RF dark-side envelope detection	30	TBAL control pin
14	BDO output pin	31	Tracking signal input pin 1
		32	Tracking signal input pin 2
15	Capacitor connection pin for RF right-side envelope detection	33	Focus signal input pin 4
		34	Focus signal input pin 2
16	OFTR output pin	35	Focus signal input pin 3
17	NRFDET output pin	36	Focus signal input pin 1

## ■ Absolute Maximum Ratings

Parameter	Symbol	Rating	Unit
Supply voltage 1 *1	V <sub>CC1</sub>	5.8	V
Supply voltage 2 *1	V <sub>CC2</sub>	5.8	V
Supply current 1 *1	I <sub>CC1</sub>	55	mA
Supply current 2 *1	I <sub>CC2</sub>	2.5	mA
Power dissipation *1, *2	P <sub>D</sub>	333.5	mW
Operating ambient temperature *1	T <sub>opr</sub>	-20 to +75	°C
Storage temperature *1	T <sub>stg</sub>	-55 to +125	°C

Note) \*1: Except for the power dissipation, operating ambient temperature and storage temperature, all ratings are for T<sub>a</sub> = 25°C.

$$*2: P_D = V_{CC1} \cdot I_{CC1} + V_{CC2} \cdot I_{CC2}$$

## ■ Recommended Operating Range

Parameter	Symbol	Range	Unit
Supply voltage 1	V <sub>CC1</sub>	4.5 to 5.5	V
Supply voltage 2	V <sub>CC2</sub>	3.0 to 5.5	V

Note) Apply voltage to satisfy V<sub>CC2</sub> - V<sub>CC1</sub> < 0.3 V.

### ■ Electrical Characteristics at $T_a = 25^\circ\text{C}$

Parameter	Symbol	Conditions	Min	Typ	Max	Unit
Current consumption with no load 1	$I_{\text{TOTAL1}}$	$V_{\text{CC1}} = 5\text{ V}$ , $V_{\text{CC2}} = 3.3\text{ V}$ $V_{\text{EQSW}} = V_{\text{REF2}} + 0.75\text{ V}$	28.4	40.6	52.8	mA
Current consumption with no load 2	$I_{\text{TOTAL2}}$	$V_{\text{CC1}} = 5\text{ V}$ , $V_{\text{CC2}} = 3.3\text{ V}$	1.20	1.72	2.24	mA
$V_{\text{REF1}}$ output voltage	$V_{\text{REF1}}$	$V_{\text{CC1}} = 5\text{ V}$ , $V_{\text{CC2}} = 3.3\text{ V}$	2.27	2.50	2.73	V
$V_{\text{REF2}}$ output voltage	$V_{\text{REF2}}$	$V_{\text{CC1}} = 5\text{ V}$ , $V_{\text{CC2}} = 3.3\text{ V}$	1.50	1.65	1.80	V
<b>Focus error amp.</b>						
Focus error amp. output offset voltage	$V_{\text{FO-OF}}$	$V_{\text{CC1}} = 5\text{ V}$ , $V_{\text{CC2}} = 3.3\text{ V}$	-90	0	90	mV
Focus error offset balance crosstalk amount	$V_{\text{FO-OFB}}$	$V_{\text{CC1}} = 5\text{ V}$ , $V_{\text{CC2}} = 3.3\text{ V}$ $V_{\text{FB}} = V_{\text{REF2}} \pm 0.5\text{ V}$	-150	0	150	mV
Focus error amp. V-V conversion gain	$G_{\text{FO}}$	$V_{\text{CC1}} = 5\text{ V}$ , $V_{\text{CC2}} = 3.3\text{ V}$ $V_{\text{GC}} = V_{\text{REF2}} - 0.75\text{ V}$	12.3	14.4	16.5	dB
Focus error amp. V-V conversion relative gain	$\Delta G_{\text{FO}}$	$V_{\text{CC1}} = 5\text{ V}$ , $V_{\text{CC2}} = 3.3\text{ V}$ $V_{\text{GC}} = V_{\text{REF2}} - 0.75\text{ V}$	-1.5	0	1.5	dB
Focus error amp. balance output 1-H	$B_{\text{FO1-H}}$	$V_{\text{CC1}} = 5\text{ V}$ , $V_{\text{CC2}} = 3.3\text{ V}$ $V_{\text{FB}} = V_{\text{REF2}} + 0.5\text{ V}$	1.08	1.35	1.62	—
Focus error amp. balance output 1-L	$B_{\text{FO1-L}}$	$V_{\text{CC1}} = 5\text{ V}$ , $V_{\text{CC2}} = 3.3\text{ V}$ $V_{\text{FB}} = V_{\text{REF2}} - 0.5\text{ V}$	0.45	0.65	0.85	—
Focus error amp. balance relative output 2-H	$B_{\text{FOH}}$	$V_{\text{CC1}} = 5\text{ V}$ , $V_{\text{CC2}} = 3.3\text{ V}$ $V_{\text{FB}} = V_{\text{REF2}} + 0.5\text{ V}$	4.35	6.35	8.35	dB
Focus error amp. balance relative output 2-L	$B_{\text{FOL}}$	$V_{\text{CC1}} = 5\text{ V}$ , $V_{\text{CC2}} = 3.3\text{ V}$ $V_{\text{FB}} = V_{\text{REF2}} - 0.5\text{ V}$	-8.35	-6.35	-4.35	dB
Focus error amp. frequency characteristics	$G_{\text{FOF}}$	$V_{\text{CC1}} = 5\text{ V}$ , $V_{\text{CC2}} = 3.3\text{ V}$ $f = 3\text{ kHz}$ , $60\text{ kHz}$	-4.5	-3.0	-1.5	dB
Focus error amp. GCTRL gain ratio $\times 4$	$B_{\text{FO4}}$	$V_{\text{CC1}} = 5\text{ V}$ , $V_{\text{CC2}} = 3.3\text{ V}$ $V_{\text{GC}} = V_{\text{REF2}}$	3.3	4.3	5.3	—
<b>Tracking error amp.</b>						
Tracking error amp. output offset voltage	$V_{\text{TR-OF}}$	$V_{\text{CC1}} = 5\text{ V}$ , $V_{\text{CC2}} = 3.3\text{ V}$	-60	0	60	mV
Tracking error offset balance crosstalk amount	$V_{\text{TR-OFB}}$	$V_{\text{CC1}} = 5\text{ V}$ , $V_{\text{CC2}} = 3.3\text{ V}$ $V_{\text{TB}} = V_{\text{REF2}} \pm 0.5\text{ V}$	-200	0	200	mV
Tracking error amp. V-V conversion gain	$G_{\text{TR}}$	$V_{\text{CC1}} = 5\text{ V}$ , $V_{\text{CC2}} = 3.3\text{ V}$ $V_{\text{GC}} = V_{\text{REF2}} - 0.75\text{ V}$	12.2	14.3	16.4	dB
Tracking error amp. V-V conversion relative gain	$\Delta G_{\text{TR}}$	$V_{\text{CC1}} = 5\text{ V}$ , $V_{\text{CC2}} = 3.3\text{ V}$ $V_{\text{GC}} = V_{\text{REF2}} - 0.75\text{ V}$	-1.5	0	1.5	dB
Tracking error amp. balance output 1-H	$B_{\text{TR1-H}}$	$V_{\text{CC1}} = 5\text{ V}$ , $V_{\text{CC2}} = 3.3\text{ V}$ $V_{\text{TB}} = V_{\text{REF2}} + 0.5\text{ V}$	0.45	0.65	0.85	—
Tracking error amp. balance output 1-L	$B_{\text{TR1-L}}$	$V_{\text{CC1}} = 5\text{ V}$ , $V_{\text{CC2}} = 3.3\text{ V}$ $V_{\text{TB}} = V_{\text{REF2}} - 0.5\text{ V}$	1.08	1.35	1.62	—

### ■ Electrical Characteristics at $T_a = 25^\circ\text{C}$ (continue)

Parameter	Symbol	Conditions	Min	Typ	Max	Unit
Tracking error amp. (continued)						
Tracking error amp. balance relative output 2-H	$B_{TRH}$	$V_{CC1} = 5\text{ V}, V_{CC2} = 3.3\text{ V}$ $V_{TB} = V_{REF2} + 0.5\text{ V}$	-8.35	-6.35	-4.35	dB
Tracking error amp. balance relative output 2-L	$B_{TRL}$	$V_{CC1} = 5\text{ V}, V_{CC2} = 3.3\text{ V}$ $V_{TB} = V_{REF2} - 0.5\text{ V}$	4.35	6.35	8.35	dB
Tracking error amp. frequency characteristics	$G_{TRF}$	$V_{CC1} = 5\text{ V}, V_{CC2} = 3.3\text{ V}$ $f = 30\text{ kHz}, 500\text{ kHz}$	-4.5	—	0	dB
Tracking error amp. GCTRL gain ratio $\times 4$	$B_{TR4}$	$V_{CC1} = 5\text{ V}, V_{CC2} = 3.3\text{ V}$ $V_{GC} = V_{REF2}$	3.3	4.3	5.3	—
CROSS detection						
CROSS high-level output	$V_{CR-H}$	$V_{CC1} = 5\text{ V}, V_{CC2} = 3.3\text{ V}, f = 10\text{ kHz}$	4.2	—	—	V
CROSS low-level output	$V_{CR-L}$	$V_{CC1} = 5\text{ V}, V_{CC2} = 3.3\text{ V}, f = 10\text{ kHz}$	—	—	0.8	V
RF addition amp.						
RF addition amp. output offset voltage	$V_{RAOF}$	$V_{CC1} = 5\text{ V}, V_{CC2} = 3.3\text{ V}$	-200	0	200	mV
RF addition amp. addition gain	$G_{RAD}$	$V_{CC1} = 5\text{ V}, V_{CC2} = 3.3\text{ V}$	-2.1	0	2.1	dB
RF addition amp. addition relative gain 1	$\Delta G_{RAD1}$	$V_{CC1} = 5\text{ V}, V_{CC2} = 3.3\text{ V}$	-1.0	0	1.0	dB
RF addition amp. addition relative gain 2	$\Delta G_{RAD2}$	$V_{CC1} = 5\text{ V}, V_{CC2} = 3.3\text{ V}$	-1.0	0	1.0	dB
RF addition amp. addition relative gain 3	$\Delta G_{RAD3}$	$V_{CC1} = 5\text{ V}, V_{CC2} = 3.3\text{ V}$	-1.0	0	1.0	dB
RF addition amp. full-addition gain	$G_{RADA}$	$V_{CC1} = 5\text{ V}, V_{CC2} = 3.3\text{ V}$	9.9	12.0	14.1	dB
RF addition amp. full-addition frequency characteristics *	$G_{RADDf}$	$V_{CC1} = 5\text{ V}, V_{CC2} = 3.3\text{ V}$ $f = 500\text{ kHz}, 30\text{ MHz}$	-3.1	-1.6	1.4	dB
Variable EQ characteristics						
EQ characteristics $\times 1-1$ *	$G_{EQ1-1}$	$f = 100\text{ kHz}$ $EQSW = V_{REF2} - 0.5\text{ V}$	-1.5	0	1.5	dB
EQ characteristics $\times 1-3$ *	$G_{EQ1-3}$	$f = 500\text{ kHz}$ $EQSW = V_{REF2} - 0.5\text{ V}$	0.5	2.0	3.5	dB
EQ characteristics $\times 20-1$ *	$G_{EQ20-1}$	$EQSW = V_{REF2} + 0.5\text{ V}$ $f = 2\text{ MHz}$	-1.5	0	1.5	dB
EQ characteristics $\times 20-3$ *	$G_{EQ20-3}$	$EQSW = V_{REF2} + 0.5\text{ V}$ $f = 13\text{ MHz}$	-1.3	0.2	1.7	dB
AGC						
AGC max. gain	$G_{MAGC}$	$f = 500\text{ kHz}, V_{IN} = 20\text{ mV[p-p]}$	20.3	23.3	26.3	dB
AGC operating gain	$G_{AGC}$	$f = 500\text{ kHz}, V_{IN} = 500\text{ mV[p-p]}$	3.0	6.0	9.0	dB
AGC compression factor	$\Delta G_{AGC}$	$f = 500\text{ kHz}, V_{IN} = 125\text{ mV[p-p]}$	-1.20	1.30	3.80	dB
AGC frequency characteristics	$G_{FAGC}$	$f = 30\text{ MHz}, V_{IN} = 20\text{ mV[p-p]}$	-4.5	-3.0	0	dB

Note) \*: The values mentioned above are subject to change according to the state of a printed circuit board, a socket, etc.

### ■ Electrical Characteristics at $T_a = 25^\circ\text{C}$ (continued)

Parameter	Symbol	Conditions	Min	Typ	Max	Unit
<b>NRF detection</b>						
NRF det. detection level	$V_{\text{RDA1}}$	$f = 500 \text{ kHz}, V_{\text{GC}} = V_{\text{REF2}} - 0.75 \text{ V}$	73	105	137	mV[p-p]
NRF det. high-level output voltage	$V_{\text{RDAH}}$	$f = 500 \text{ kHz}, V_{\text{GC}} = V_{\text{REF2}} - 0.75 \text{ V}$	4.2	—	—	V
NRF det. low-level output voltage	$V_{\text{RDAL}}$	$f = 500 \text{ kHz}, V_{\text{GC}} = V_{\text{REF2}} - 0.75 \text{ V}$	—	—	0.8	V
NRF det. detection level ratio	$B_{\text{RDA}}$	$f = 500 \text{ kHz}, V_{\text{GC}} = V_{\text{REF2}}$	2.9	3.9	4.9	—
<b>BDO</b>						
CBDO detection current	$I_{\text{BDO}}$	$V_{\text{CC1}} = 5 \text{ V}, V_{\text{CC2}} = 3.3 \text{ V}$ $\text{EQSW} = V_{\text{REF2}} - 0.5 \text{ V}$	0.98	1.40	1.82	$\mu\text{A}$
CBDO detection current ratio	$B_{\text{IBD4}}$	$V_{\text{CC1}} = 5 \text{ V}, V_{\text{CC2}} = 3.3 \text{ V}$ $\text{EQSW} = V_{\text{REF2}}$	3.0	3.8	4.6	—
BDO high-level output voltage	$V_{\text{BDOH}}$	$V_{\text{CC1}} = 5 \text{ V}, V_{\text{CC2}} = 3.3 \text{ V}$ $f = 5 \text{ kHz}, \text{rectangular wave}$	4.2	—	—	V
BDO low-level output voltage	$V_{\text{BDOL}}$	$V_{\text{CC1}} = 5 \text{ V}, V_{\text{CC2}} = 3.3 \text{ V}$ $f = 5 \text{ kHz}, \text{rectangular wave}$	—	—	0.8	V
<b>OFTR</b>						
COFTR detection current	$I_{\text{OFTR}}$	$V_{\text{CC1}} = 5 \text{ V}, V_{\text{CC2}} = 3.3 \text{ V}$ $\text{EQSW} = V_{\text{REF2}} - 0.5 \text{ V}$	0.98	1.40	1.82	$\mu\text{A}$
COFTR detection current ratio	$B_{\text{IOFTR4}}$	$V_{\text{CC1}} = 5 \text{ V}, V_{\text{CC2}} = 3.3 \text{ V}$ $\text{EQSW} = V_{\text{REF2}}$	3.0	3.8	4.6	—
OFTR high-level output voltage	$V_{\text{OFTRH}}$	$V_{\text{CC1}} = 5 \text{ V}, V_{\text{CC2}} = 3.3 \text{ V}$ $f = 5 \text{ kHz}, \text{rectangular wave}$	4.2	—	—	V
OFTR low-level output voltage	$V_{\text{OFTRL}}$	$V_{\text{CC1}} = 5 \text{ V}, V_{\text{CC2}} = 3.3 \text{ V}$ $f = 5 \text{ kHz}, \text{rectangular wave}$	—	—	0.8	V
Masking operating voltage 1	$V_{\text{MASK1}}$	$f = 40 \text{ kHz}, V_{\text{IN}} = 100 \text{ mV[p-p]}$	—	—	0.35	V
Masking operating voltage 2	$V_{\text{MASK2}}$	$f = 40 \text{ kHz}, V_{\text{IN}} = 100 \text{ mV[p-p]}$	0.65	—	—	V
<b>3TENV</b>						
CEA to ENV transfer characteristics	$G_{\text{CEA-ENV}}$	$V_{\text{CC1}} = 5 \text{ V}, V_{\text{CC2}} = 3.3 \text{ V}$	20.0	23.0	26.0	dB
CEA input impedance	$Z_{\text{CEA}}$	$V_{\text{CC1}} = 5 \text{ V}, V_{\text{CC2}} = 3.3 \text{ V}$	6.8	8.8	10.8	$\text{k}\Omega$
ENV amp. output impedance	$Z_{\text{ENV}}$	$V_{\text{CC1}} = 5 \text{ V}, V_{\text{CC2}} = 3.3 \text{ V}$	6.4	8.4	10.4	$\text{k}\Omega$
ENV amp. offset voltage	$V_{\text{ENVOF}}$	$V_{\text{CC1}} = 5 \text{ V}, V_{\text{CC2}} = 3.3 \text{ V}$	-100	0	100	mV
ENV amp. operation	$V_{\text{ENV}}$	$V_{\text{CC1}} = 5 \text{ V}, V_{\text{CC2}} = 3.3 \text{ V}$ $f = 800 \text{ kHz}, \text{AM modulation}$	270	540	810	mV[p-p]
<b>LD APC</b>						
LD operating reference voltage	$V_{\text{LD}}$	$V_{\text{CC1}} = 5 \text{ V}, V_{\text{CC2}} = 3.3 \text{ V}$	135	170	205	mV
LDON operating voltage	$V_{\text{LDON}}$	$V_{\text{CC1}} = 5 \text{ V}, V_{\text{CC2}} = 3.3 \text{ V}$	—	—	-0.35	V

Application Circuit Example

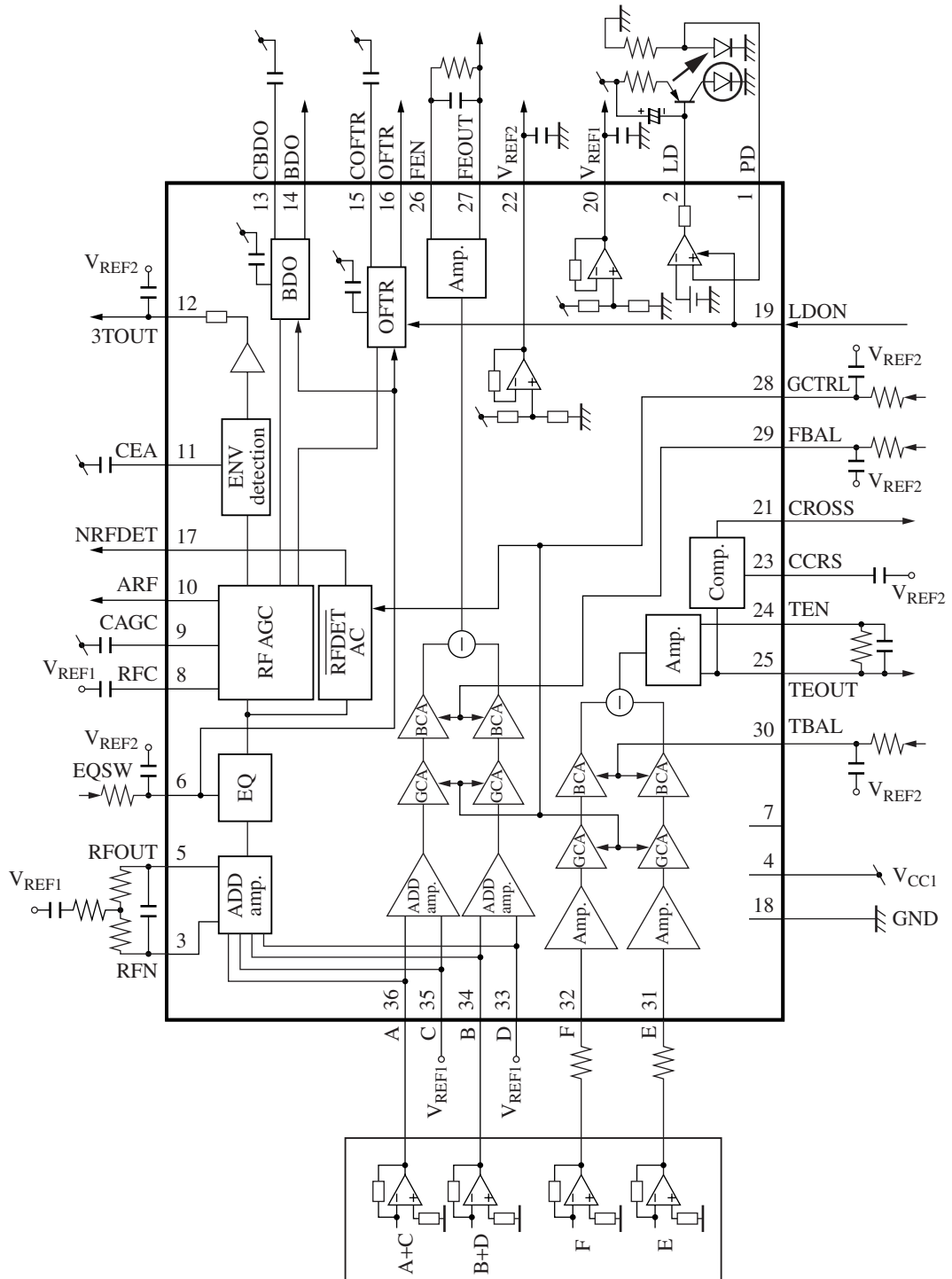

## ■ New Package Dimensions (Unit: mm)

- SSOP036-P-0450C (Lead-free package)

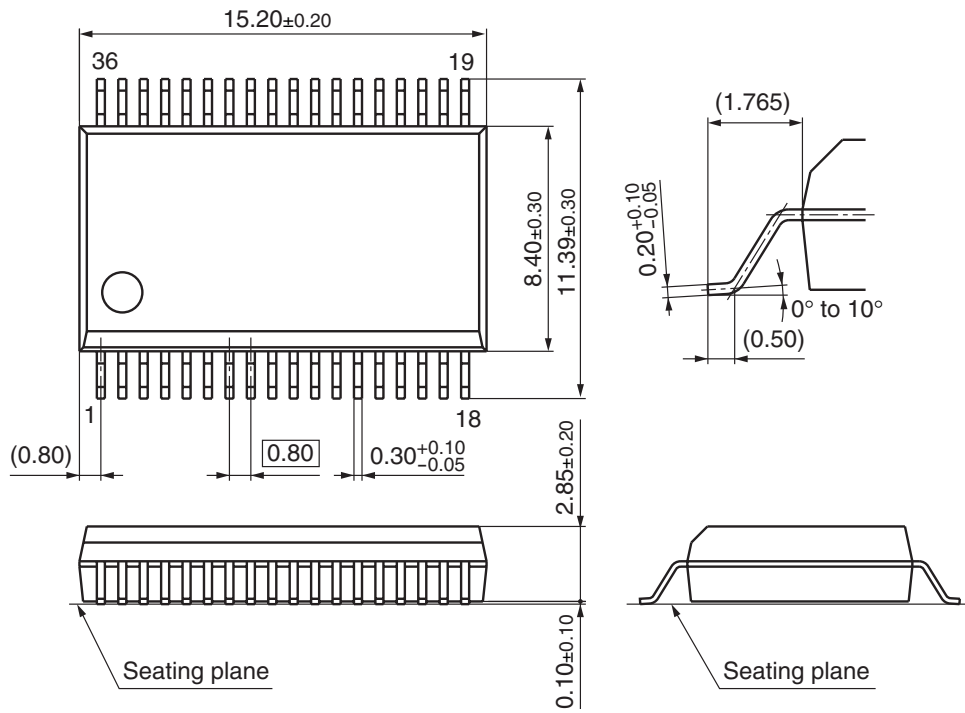

## Request for your special attention and precautions in using the technical information and semiconductors described in this material

- (1) An export permit needs to be obtained from the competent authorities of the Japanese Government if any of the products or technologies described in this material and controlled under the "Foreign Exchange and Foreign Trade Law" is to be exported or taken out of Japan.
- (2) The technical information described in this material is limited to showing representative characteristics and applied circuit examples of the products. It does not constitute the warranting of industrial property, the granting of relative rights, or the granting of any license.
- (3) The products described in this material are intended to be used for standard applications or general electronic equipment (such as office equipment, communications equipment, measuring instruments and household appliances).  
Consult our sales staff in advance for information on the following applications:
  - Special applications (such as for airplanes, aerospace, automobiles, traffic control equipment, combustion equipment, life support systems and safety devices) in which exceptional quality and reliability are required, or if the failure or malfunction of the products may directly jeopardize life or harm the human body.
  - Any applications other than the standard applications intended.
- (4) The products and product specifications described in this material are subject to change without notice for reasons of modification and/or improvement. At the final stage of your design, purchasing, or use of the products, therefore, ask for the most up-to-date Product Standards in advance to make sure that the latest specifications satisfy your requirements.
- (5) When designing your equipment, comply with the guaranteed values, in particular those of maximum rating, the range of operating power supply voltage and heat radiation characteristics. Otherwise, we will not be liable for any defect which may arise later in your equipment.  
Even when the products are used within the guaranteed values, redundant design is recommended, so that such equipment may not violate relevant laws or regulations because of the function of our products.
- (6) When using products for which dry packing is required, observe the conditions (including shelf life and after-unpacking standby time) agreed upon when specification sheets are individually exchanged.
- (7) No part of this material may be reprinted or reproduced by any means without written permission from our company.

## Please read the following notes before using the datasheets

- A. These materials are intended as a reference to assist customers with the selection of Panasonic semiconductor products best suited to their applications.  
Due to modification or other reasons, any information contained in this material, such as available product types, technical data, and so on, is subject to change without notice.  
Customers are advised to contact our semiconductor sales office and obtain the latest information before starting precise technical research and/or purchasing activities.
- B. Panasonic is endeavoring to continually improve the quality and reliability of these materials but there is always the possibility that further rectifications will be required in the future. Therefore, Panasonic will not assume any liability for any damages arising from any errors etc. that may appear in this material.
- C. These materials are solely intended for a customer's individual use.  
Therefore, without the prior written approval of Panasonic, any other use such as reproducing, selling, or distributing this material to a third party, via the Internet or in any other way, is prohibited.



LittleDiode supplies new, hard to find or obsolete electronic components and semiconductors all over the world.

With over two million different components listed you are sure to find the part you need.

Feel free to visit us today at our online store:

[LittleDiode.com](http://LittleDiode.com)

Looking forward to providing you with the best possible service.