

1 - Cathode
2 - Anode
Back of Case - Cathode

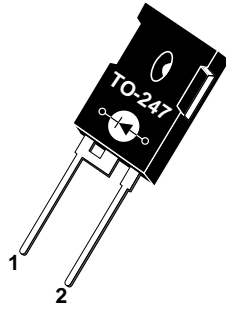

**ADVANCED
POWER
TECHNOLOGY®**
APT100S20B 200V 100A

HIGH VOLTAGE SCHOTTKY DIODE

PRODUCT APPLICATIONS	PRODUCT FEATURES	PRODUCT BENEFITS
<ul style="list-style-type: none"> • Parallel Diode <ul style="list-style-type: none"> -Switchmode Power Supply -Inverters • Free Wheeling Diode <ul style="list-style-type: none"> -Motor Controllers -Converters • Snubber Diode • Uninterruptible Power Supply (UPS) • 48 Volt Output Rectifiers • High Speed Rectifiers 	<ul style="list-style-type: none"> • Ultrafast Recovery Times • Soft Recovery Characteristics • Popular TO-247 Package • Rugged - Avalanche Energy Rated • Low Forward Voltage • High Blocking Voltage • Low Leakage Current 	<ul style="list-style-type: none"> • Low Losses • Low Noise Switching • Cooler Operation • Higher Reliability Systems • Increased System Power Density

MAXIMUM RATINGS

All Ratings: $T_C = 25^\circ\text{C}$ unless otherwise specified.

Symbol	Characteristic / Test Conditions	APT100S20B	UNIT
V_R	Maximum D.C. Reverse Voltage	200	Volts
V_{RRM}	Maximum Peak Repetitive Reverse Voltage		
V_{RWM}	Maximum Working Peak Reverse Voltage		
$I_F(AV)$	Maximum Average Forward Current ($T_C = 125^\circ\text{C}$, Duty Cycle = 0.5) ^①	100	Amps
$I_F(RMS)$	RMS Forward Current ^①	100	
I_{FSM}	Non-Repetitive Forward Surge Current ($T_J = 45^\circ\text{C}$, 8.3ms)	1000	
T_J, T_{STG}	Operating and Storage Temperature Range	-55 to 150	°C
T_L	Lead Temperature: 0.063" from Case for 10 Sec.	300	
E_{AVL}	Avalanche Energy (2A, 50 mH)	100	mJ

STATIC ELECTRICAL CHARACTERISTICS

Symbol	Characteristic / Test Conditions	MIN	TYP	MAX	UNIT
V_F	Maximum Forward Voltage	$I_F = 100\text{A}$	0.89	0.95	Volts
		$I_F = 200\text{A}$	1.18		
		$I_F = 100\text{A}, T_J = 150^\circ\text{C}$		0.80	
I_{RM}	Maximum Reverse Leakage Current	$V_R = V_R$ Rated		2	mA
		$V_R = V_R$ Rated, $T_J = 125^\circ\text{C}$		50	
C_T	Junction Capacitance, $V_R = 200\text{V}$		470		pF
L_S	Series Inductance (Lead to Lead 5mm from Base)		10		nH

APT Website - <http://www.advancedpower.com>

USA 405 S.W. Columbia Street
EUROPE Chemin de Magret

Bend, Oregon 97702-1035
F-33700 Merignac - France

Phone: (541) 382-8028
Phone: (33) 5 57 92 15 15

FAX: (541) 388-0364
FAX: (33) 5 56 47 97 61

DYNAMIC CHARACTERISTICS

APT100S20B

Symbol	Characteristic	MIN	TYP	MAX	UNIT
t_{rr1}	Reverse Recovery Time, $I_F = 1.0A$, $di_F/dt = -15A/\mu s$, $V_R = 30V$, $T_J = 25^\circ C$		110		ns
t_{rr2}	Reverse Recovery Time		88		
t_{rr3}	$I_F = 100A$, $di_F/dt = -100A/\mu s$, $V_R = 100V$		123		
t_{fr1}	Forward Recovery Time		1600		
t_{fr2}	$I_F = 100A$, $di_F/dt = 100A/\mu s$, $V_R = 100V$		1600		
I_{RRM1}	Reverse Recovery Current		5		Amps
I_{RRM2}	$I_F = 100A$, $di_F/dt = -100A/\mu s$, $V_R = 100V$		7		
Q_{rr1}	Recovery Charge		253		nC
Q_{rr2}	$I_F = 100A$, $di_F/dt = -100A/\mu s$, $V_R = 100V$		490		
V_{fr1}	Forward Recovery Voltage		6.0		Volts
V_{fr2}	$I_F = 100A$, $di_F/dt = 100A/\mu s$, $V_R = 100V$		6.0		
diM/dt	Rate of Fall of Recovery Current		210		A/ μs
	$I_F = 100A$, $di_F/dt = -100A/\mu s$, $V_R = 100V$		250		

THERMAL AND MECHANICAL CHARACTERISTICS

Symbol	Characteristic / Test Conditions	MIN	TYP	MAX	UNIT
$R_{\theta JC}$	Junction-to-Case Thermal Resistance			.24	$^\circ C/W$
$R_{\theta JA}$	Junction-to-Ambient Thermal Resistance			40	
W_T	Package Weight		0.35		oz
			9.9		gm
Torque	Maximum Mounting Torque (Screw Type = 6-32 or 3mm Machine)			10	lb•in
				1.1	N•m

① The maximum current is limited by lead temperature

APT Reserves the right to change, without notice, the specifications and information contained herein.

TO-247 Package Outline

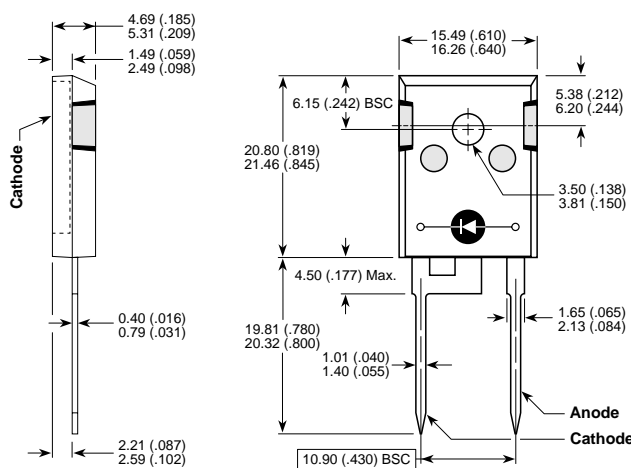

Dimensions in Millimeters and (Inches)

APT's devices are covered by one or more of the following U.S.patents:

- 4,895,810
- 5,045,903
- 5,089,434
- 5,182,234
- 5,019,522
- 5,262,336
- 5,256,583
- 4,748,103
- 5,283,202
- 5,231,474
- 5,434,095
- 5,528,058



LittleDiode supplies new, hard to find or obsolete electronic components and semiconductors all over the world.

With over two million different components listed you are sure to find the part you need.

Feel free to visit us today at our online store:

LittleDiode.com

Looking forward to providing you with the best possible service.