

- 1 - Anode 1
- 2 - Common Cathode
Back of Case - Cathode
- 3 - Anode 2

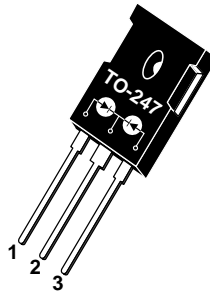

APT30D20BCT 200V 2x30A

ULTRAFAST SOFT RECOVERY RECTIFIER DIODES

PRODUCT APPLICATIONS	PRODUCT FEATURES	PRODUCT BENEFITS
<ul style="list-style-type: none"> • Parallel Diode <ul style="list-style-type: none"> -Switchmode Power Supply -Inverters • Free Wheeling Diode <ul style="list-style-type: none"> -Motor Controllers -Converters • Snubber Diode • Uninterruptible Power Supply (UPS) • Induction Heating • High Speed Rectifiers 	<ul style="list-style-type: none"> • Ultrafast Recovery Times • Soft Recovery Characteristics • Popular TO-247 Package • Low Forward Voltage • High Blocking Voltage • Low Leakage Current 	<ul style="list-style-type: none"> • Low Losses • Low Noise Switching • Cooler Operation • Higher Reliability Systems • Increased System Power Density

MAXIMUM RATINGS

All Ratings Are Per Leg: $T_C = 25^\circ\text{C}$ unless otherwise specified.

Symbol	Characteristic / Test Conditions	APT30D20BCT	UNIT
V_R	Maximum D.C. Reverse Voltage	200	Volts
V_{RRM}	Maximum Peak Repetitive Reverse Voltage		
V_{RWM}	Maximum Working Peak Reverse Voltage		
$I_F(AV)$	Maximum Average Forward Current ($T_C = 85^\circ\text{C}$, Duty Cycle = 0.5)	30	Amps
$I_F(RMS)$	RMS Forward Current	70	
I_{FSM}	Non-Repetitive Forward Surge Current ($T_J = 45^\circ\text{C}$, 8.3ms)	320	
T_J, T_{STG}	Operating and Storage Temperature Range	-55 to 150	$^\circ\text{C}$
T_L	Lead Temperature: 0.063" from Case for 10 Sec.	300	

STATIC ELECTRICAL CHARACTERISTICS

Symbol	Characteristic / Test Conditions	MIN	TYP	MAX	UNIT
V_F	Maximum Forward Voltage			1.15	Volts
				$I_F = 30\text{A}$	
				$I_F = 60\text{A}$	
I_{RM}	Maximum Reverse Leakage Current			250	μA
				$V_R = V_R \text{ Rated}$	
C_T	Junction Capacitance, $V_R = 150\text{V}$		110		pF
L_S	Series Inductance (Lead to Lead 5mm from Base)		10		nH

USA

405 S.W. Columbia Street
EUROPE

Avenue J.F. Kennedy Bât B4 Parc Cadéra Nord

Bend, Oregon 97702-1035

F-33700 Merignac - France

Phone: (541) 382-8028

Phone: (33) 5 57 92 15 15

FAX: (541) 388-0364

FAX: (33) 5 56 479 61

DYNAMIC CHARACTERISTICS

APT30D20BCT

Symbol	Characteristic	MIN	TYP	MAX	UNIT
t_{rr1}	Reverse Recovery Time, $I_F = 1.0A$, $di_F/dt = -15A/\mu s$, $V_R = 30V$, $T_J = 25^\circ C$		35	50	ns
t_{rr2}	Reverse Recovery Time	$T_J = 25^\circ C$	40		
t_{rr3}	$I_F = 30A$, $di_F/dt = -240A/\mu s$, $V_R = 100V$	$T_J = 100^\circ C$	60		
t_{fr1}	Forward Recovery Time	$T_J = 25^\circ C$	155		
t_{fr2}	$I_F = 30A$, $di_F/dt = 240A/\mu s$, $V_R = 100V$	$T_J = 100^\circ C$	155		
I_{RRM1}	Reverse Recovery Current	$T_J = 25^\circ C$	6	8	Amps
I_{RRM2}	$I_F = 30A$, $di_F/dt = -240A/\mu s$, $V_R = 100V$	$T_J = 100^\circ C$	10	13	
Q_{rr1}	Recovery Charge	$T_J = 25^\circ C$	120		nC
Q_{rr2}	$I_F = 30A$, $di_F/dt = -240A/\mu s$, $V_R = 100V$	$T_J = 100^\circ C$	300		
V_{fr1}	Forward Recovery Voltage	$T_J = 25^\circ C$	2.5		Volts
V_{fr2}	$I_F = 30A$, $di_F/dt = 240A/\mu s$, $V_R = 100V$	$T_J = 100^\circ C$	2.5		
diM/dt	Rate of Fall of Recovery Current	$T_J = 25^\circ C$	300		A/ μs
	$I_F = 30A$, $di_F/dt = -240A/\mu s$, $V_R = 100V$ (See Figure 10)	$T_J = 100^\circ C$	600		

THERMAL AND MECHANICAL CHARACTERISTICS

Symbol	Characteristic / Test Conditions	MIN	TYP	MAX	UNIT
$R_{\theta JC}$	Junction-to-Case Thermal Resistance			0.90	$^\circ C/W$
$R_{\theta JA}$	Junction-to-Ambient Thermal Resistance			40	
W_T	Package Weight		0.22		oz
			6.1		gm
Torque	Maximum Mounting Torque (Screw Type = 6-32 or 3mm Machine)			10	lb•in
				1.1	N•m

APT Reserves the right to change, without notice, the specifications and information contained herein.

TO-247AD Package Outline

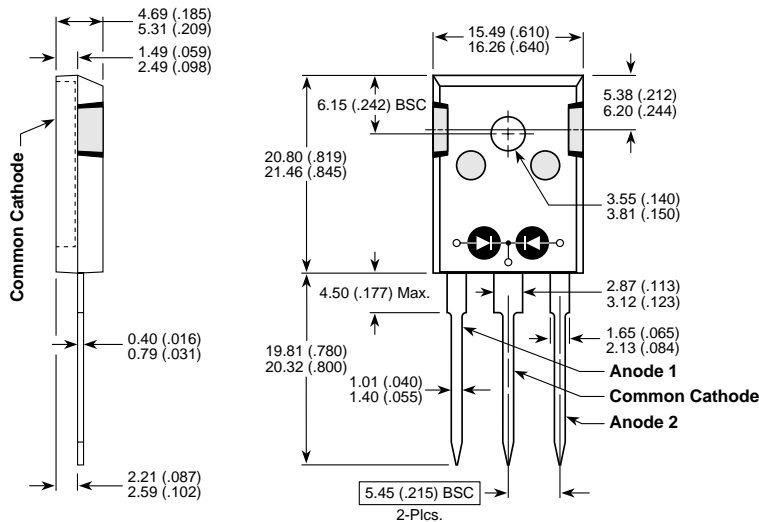

Dimensions in Millimeters and (Inches)



LittleDiode supplies new, hard to find or obsolete electronic components and semiconductors all over the world.

With over two million different components listed you are sure to find the part you need.

Feel free to visit us today at our online store:

LittleDiode.com

Looking forward to providing you with the best possible service.