

Fast IGBT & FRED

The Fast IGBT™ is a new generation of high voltage power IGBTs. Using Non-Punch Through Technology the Fast IGBT™ combined with an APT free-wheeling ultraFast Recovery Epitaxial Diode (FRED) offers superior ruggedness and fast switching speed.

- Low Forward Voltage Drop
- Low Tail Current
- RBSOA and SCSOA Rated
- Ultrafast Soft Recovery Antiparallel Diode
- High Freq. Switching to 20KHz
- Ultra Low Leakage Current

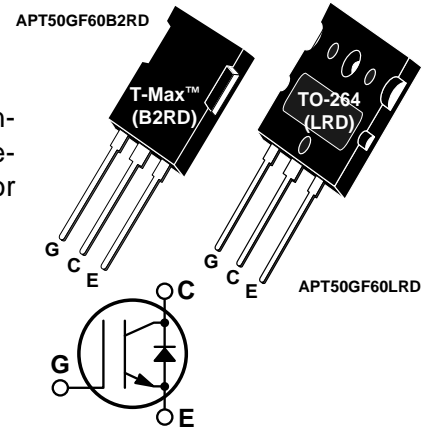

MAXIMUM RATINGS (IGBT)

All Ratings: $T_C = 25^\circ\text{C}$ unless otherwise specified.

Symbol	Parameter	APT50GF60B2RD/LRD	UNIT
V_{CES}	Collector-Emitter Voltage	600	Volts
V_{CGR}	Collector-Gate Voltage ($R_{GE} = 20K\Omega$)	600	
V_{GE}	Gate-Emitter Voltage	± 20	
I_{C1}	Continuous Collector Current @ $T_C = 25^\circ\text{C}$	80	Amps
I_{C2}	Continuous Collector Current @ $T_C = 90^\circ\text{C}$	50	
I_{CM1}	Pulsed Collector Current ^① @ $T_C = 25^\circ\text{C}$	160	
I_{CM2}	Pulsed Collector Current ^① @ $T_C = 90^\circ\text{C}$	100	
P_D	Total Power Dissipation	300	Watts
T_J, T_{STG}	Operating and Storage Junction Temperature Range	-55 to 150	$^\circ\text{C}$
T_L	Max. Lead Temp. for Soldering: 0.063" from Case for 10 Sec.	300	

STATIC ELECTRICAL CHARACTERISTICS (IGBT)

Symbol	Characteristic / Test Conditions	MIN	TYP	MAX	UNIT
BV_{CES}	Collector-Emitter Breakdown Voltage ($V_{GE} = 0V, I_C = 0.50\text{mA}$)	600			Volts
$V_{GE(TH)}$	Gate Threshold Voltage ($V_{CE} = V_{GE}, I_C = 700\mu\text{A}, T_J = 25^\circ\text{C}$)	4.5	5.5	6.5	
$V_{CE(ON)}$	Collector-Emitter On Voltage ($V_{GE} = 15V, I_C = I_{C2}, T_J = 25^\circ\text{C}$)		2.1	2.7	
	Collector-Emitter On Voltage ($V_{GE} = 15V, I_C = I_{C2}, T_J = 125^\circ\text{C}$)		2.2	2.8	
I_{CES}	Collector Cut-off Current ($V_{CE} = V_{CES}, V_{GE} = 0V, T_J = 25^\circ\text{C}$) ^②			0.50	mA
	Collector Cut-off Current ($V_{CE} = V_{CES}, V_{GE} = 0V, T_J = 125^\circ\text{C}$) ^②			TBD	
I_{GES}	Gate-Emitter Leakage Current ($V_{GE} = \pm 20V, V_{CE} = 0V$)			± 100	nA

 **CAUTION:** These Devices are Sensitive to Electrostatic Discharge. Proper Handling Procedures Should Be Followed.

USA
405 S.W. Columbia Street

EUROPE
Avenue J.F. Kennedy Bât B4 Parc Cadéra Nord

APT Website - <http://www.advancedpower.com>

Bend, Oregon 97702-1035

Phone: (541) 382-8028

FAX: (541) 388-0364

F-33700 Merignac - France

Phone: (33) 5 57 92 15 15

FAX: (33) 5 56 47 97 61

DYNAMIC CHARACTERISTICS (IGBT)
APT50GF60B2RD/LRD

Symbol	Characteristic	Test Conditions	MIN	TYP	MAX	UNIT
C_{ies}	Input Capacitance	Capacitance $V_{GE} = 0V$ $V_{CE} = 25V$ $f = 1\text{ MHz}$		2600	3600	pF
C_{oes}	Output Capacitance			475	710	
C_{res}	Reverse Transfer Capacitance			165	250	
Q_g	Total Gate Charge ^③	Gate Charge $V_{GE} = 15V$ $V_{CC} = 0.5V_{CES}$ $I_C = I_{C2}$		170	225	nC
Q_{ge}	Gate-Emitter Charge			25	45	
Q_{gc}	Gate-Collector ("Miller") Charge			100	140	
$t_{d(on)}$	Turn-on Delay Time	Resistive Switching (25°C) $V_{GE} = 15V$ $V_{CC} = .8V_{CES}$ $I_C = I_{C2}$ $R_G = 10\Omega$		20		ns
t_r	Rise Time			100		
$t_{d(off)}$	Turn-off Delay Time			160		
t_f	Fall Time			200		
$t_{d(on)}$	Turn-on Delay Time	Inductive Switching (150°C) $V_{CLAMP(Peak)} = 0.66V_{CES}$ $V_{GE} = 15V$ $I_C = I_{C2}$ $R_G = 10\Omega$ $T_J = +150^\circ C$		30	50	ns
t_r	Rise Time			90	135	
$t_{d(off)}$	Turn-off Delay Time			290	435	
t_f	Fall Time			170	340	
E_{on}	Turn-on Switching Energy ^④			2.2		mJ
E_{off}	Turn-off Switching Energy			2.4		
E_{ts}	Total Switching Losses ^④			4.6		
$t_{d(on)}$	Turn-on Delay Time	Inductive Switching (25°C) $V_{CLAMP(Peak)} = 0.66V_{CES}$ $V_{GE} = 15V$ $I_C = I_{C2}$ $R_G = 10\Omega$ $T_J = +25^\circ C$		30		ns
t_r	Rise Time			90		
$t_{d(off)}$	Turn-off Delay Time			260		
t_f	Fall Time			100		
E_{ts}	Total Switching Losses ^④			4.3		mJ
gfe	Forward Transconductance	$V_{CE} = 20V, I_C = I_{C2}$	6			S

THERMAL AND MECHANICAL CHARACTERISTICS (IGBT and FRED)

Symbol	Characteristic	MIN	TYP	MAX	UNIT
$R_{\theta JC}$	Junction to Case (IGBT)			0.42	°C/W
	Junction to Case (FRED)			0.66	
$R_{\theta JA}$	Junction to Ambient			40	
W_T	Package Weight		0.22		oz
			6.1		gm
Torque	Mounting Torque using a 6-32 or 3mm Binding Head Machine Screw			10	lb•in
				1.1	N•m

① Repetitive Rating: Pulse width limited by maximum junction temperature.

② Leakages include the FRED and IGBT.

③ See MIL-STD-750 Method 3471

④ Switching losses include the FRED and IGBT.

APT Reserves the right to change, without notice, the specifications and information contained herein.

Power dissipation

$$P_{\text{tot}} = f(T_C)$$

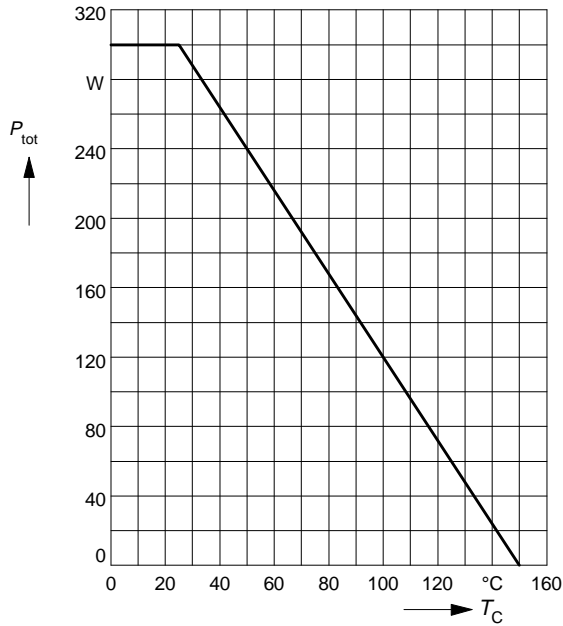
 parameter: $T_j \leq 150\text{ }^\circ\text{C}$

Collector current

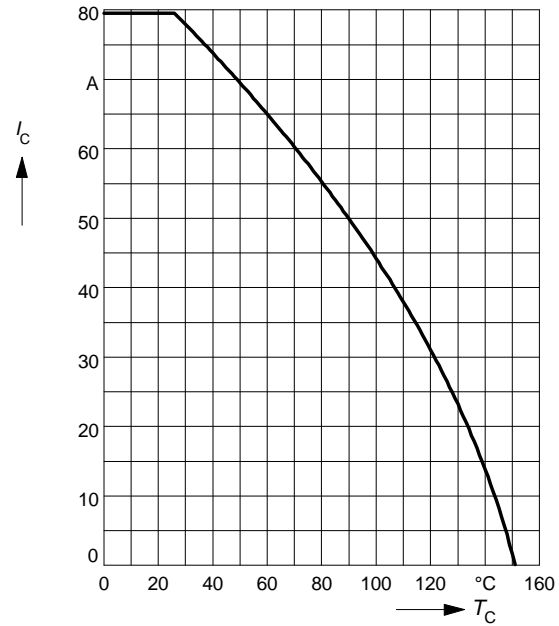
$$I_C = f(T_C)$$

 parameter: $V_{GE} \geq 15\text{ V}$, $T_j \leq 150\text{ }^\circ\text{C}$

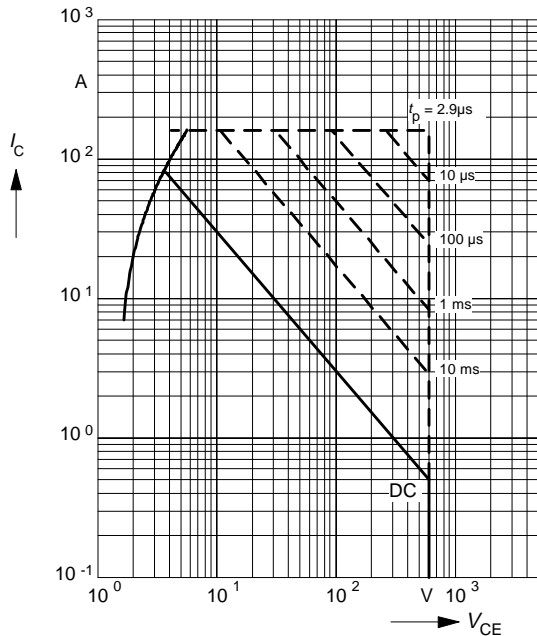
Safe operating area

$$I_C = f(V_{CE})$$

 parameter: $D = 0$, $T_C = 25\text{ }^\circ\text{C}$, $T_j \leq 150\text{ }^\circ\text{C}$

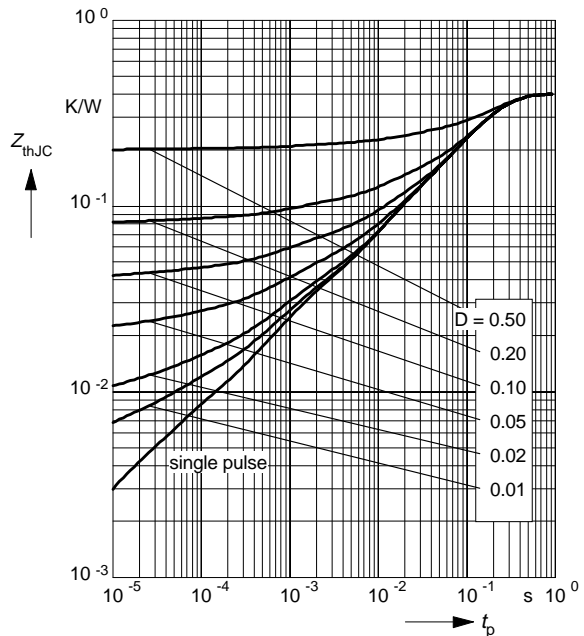
Transient thermal impedance IGBT

$$Z_{\text{thJC}} = f(t_p)$$

 parameter: $D = t_p / T$

EUROPE

 Avenue J.F. Kennedy Bât B4 Parc Cadéra Nord
USA

405 S.W. Columbia Street

F-33700 Merignac - France

Bend, Oregon 97702-1035

Phone: (33) 5 57 92 15 15
Phone: (541) 382-8028
FAX: (33) 5 56 47 97 61
FAX: (541) 388-0364

Typ. output characteristics

$$I_C = f(V_{CE})$$

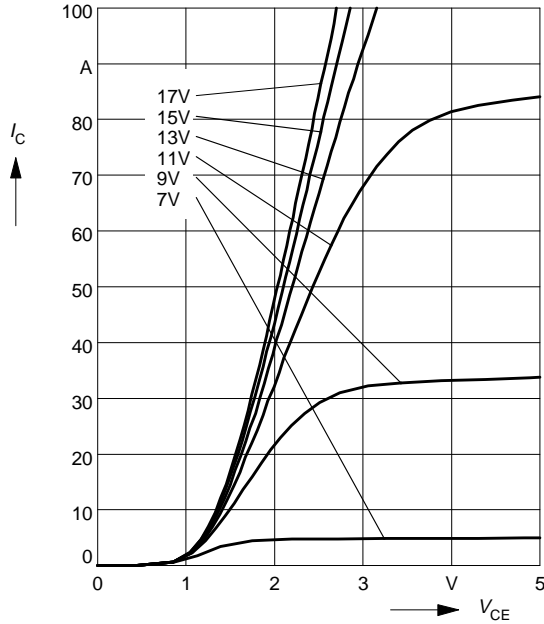
 parameter: $t_p = 80 \mu s$, $T_j = 25^\circ C$

Typ. output characteristics

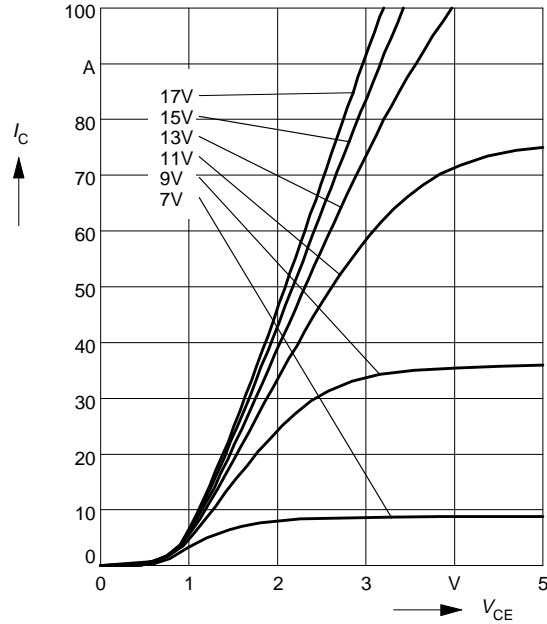
$$I_C = f(V_{CE})$$

 parameter: $t_p = 80 \mu s$, $T_j = 125^\circ C$

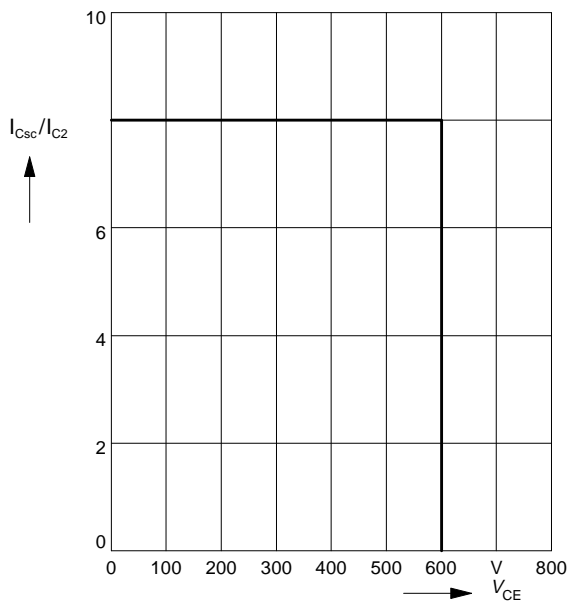
Short circuit safe operating area

$$I_{Csc} = f(V_{CE}), T_j = 150^\circ C$$

 parameter: $V_{GE} = \pm 15 V$, $t_{sc} \leq 10 \mu s$, $L < 50 nH$

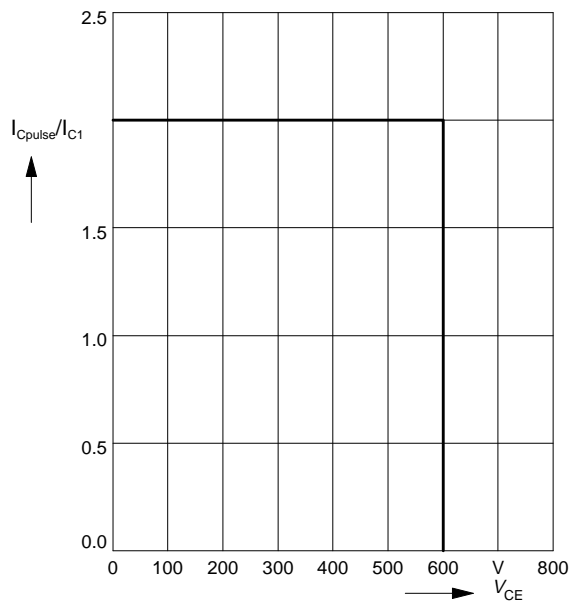
Reverse biased safe operating area

$$I_{Cpuls} = f(V_{CE}), T_j = 150^\circ C$$

 parameter: $V_{GE} = 15 V$

ULTRAFAST SOFT RECOVERY PARALLEL DIODE

MAXIMUM RATINGS (FRED)

All Ratings: $T_C = 25^\circ\text{C}$ unless otherwise specified.

Symbol	Characteristic / Test Conditions	APT50GF60B2RD/LRD	UNIT
V_R	Maximum D.C. Reverse Voltage	600	Volts
V_{RRM}	Maximum Peak Repetitive Reverse Voltage		
V_{RWM}	Maximum Working Peak Reverse Voltage		
$I_F(AV)$	Maximum Average Forward Current ($T_C = 85^\circ\text{C}$, Duty Cycle = 0.5)	60	Amps
$I_F(RMS)$	RMS Forward Current	100	
I_{FSM}	Non-Repetitive Forward Surge Current ($T_J = 45^\circ\text{C}$, 8.3ms)	600	

STATIC ELECTRICAL CHARACTERISTICS (FRED)

Symbol	Characteristic / Test Conditions	MIN	TYP	MAX	UNIT
V_F	Maximum Forward Voltage			1.8	Volts
				$I_F = 60\text{A}$	
			$I_F = 120\text{A}$	1.75	
	$I_F = 60\text{A}, T_J = 150^\circ\text{C}$			1.5	

DYNAMIC CHARACTERISTICS (FRED)

Symbol	Characteristic	MIN	TYP	MAX	UNIT
t_{rr1}	Reverse Recovery Time, $I_F = 1.0\text{A}$, $di_F/dt = -15\text{A}/\mu\text{s}$, $V_R = 30\text{V}$, $T_J = 25^\circ\text{C}$		55	70	ns
t_{rr2}	Reverse Recovery Time		$T_J = 25^\circ\text{C}$ 70		
t_{rr3}	$I_F = 60\text{A}$, $di_F/dt = -480\text{A}/\mu\text{s}$, $V_R = 350\text{V}$		$T_J = 100^\circ\text{C}$ 90		
t_{fr1}	Forward Recovery Time		$T_J = 25^\circ\text{C}$ 160		Amps
t_{fr2}	$I_F = 60\text{A}$, $di_F/dt = 480\text{A}/\mu\text{s}$, $V_R = 350\text{V}$		$T_J = 100^\circ\text{C}$ 160		
I_{RRM1}	Reverse Recovery Current		$T_J = 25^\circ\text{C}$ 10	17	Amps
I_{RRM2}	$I_F = 60\text{A}$, $di_F/dt = -480\text{A}/\mu\text{s}$, $V_R = 350\text{V}$		$T_J = 100^\circ\text{C}$ 20	30	
Q_{rr1}	Recovery Charge		$T_J = 25^\circ\text{C}$ 350		nC
Q_{rr2}	$I_F = 60\text{A}$, $di_F/dt = -480\text{A}/\mu\text{s}$, $V_R = 350\text{V}$		$T_J = 100^\circ\text{C}$ 900		
V_{fr1}	Forward Recovery Voltage		$T_J = 25^\circ\text{C}$ 6		Volts
V_{fr2}	$I_F = 60\text{A}$, $di_F/dt = 480\text{A}/\mu\text{s}$, $V_R = 350\text{V}$		$T_J = 100^\circ\text{C}$ 6		
diM/dt	Rate of Fall of Recovery Current		$T_J = 25^\circ\text{C}$ 800		A/ μs
	$I_F = 60\text{A}$, $di_F/dt = -480\text{A}/\mu\text{s}$, $V_R = 350\text{V}$		$T_J = 100^\circ\text{C}$ 500		

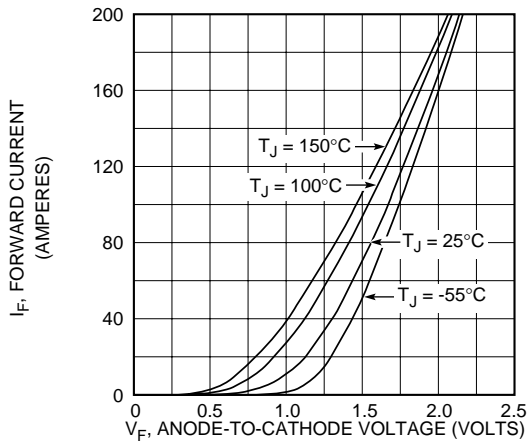

Figure 1, Forward Voltage Drop vs Forward Current

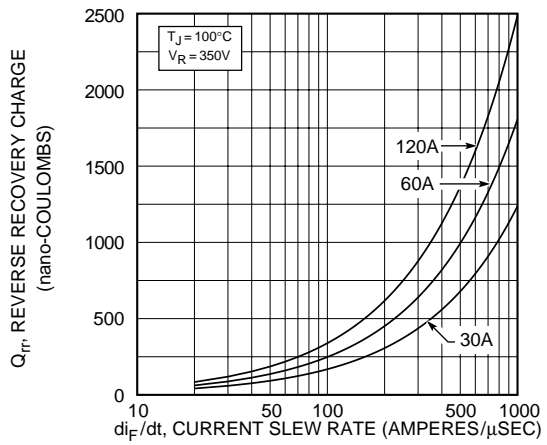

Figure 2, Reverse Recovery Charge vs Current Slew Rate

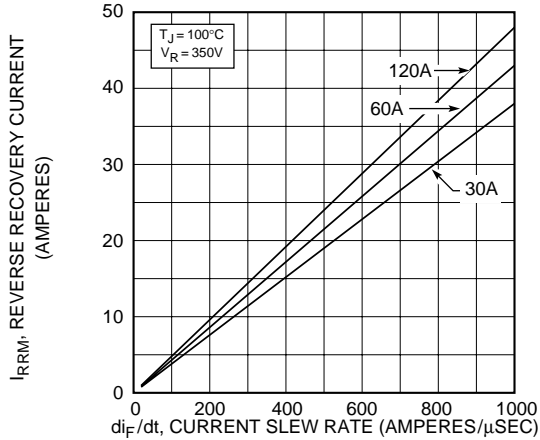

Figure 3, Reverse Recovery Current vs Current Slew Rate

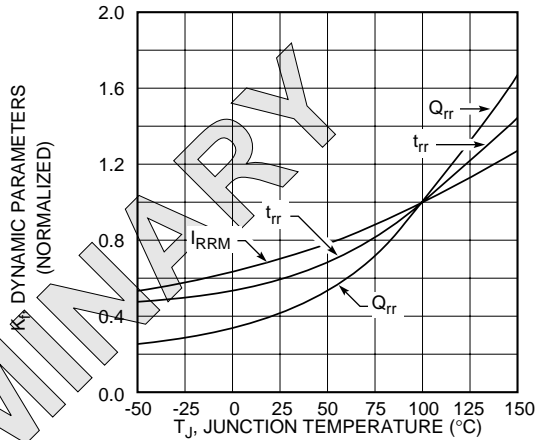

Figure 4, Dynamic Parameters vs Junction Temperature

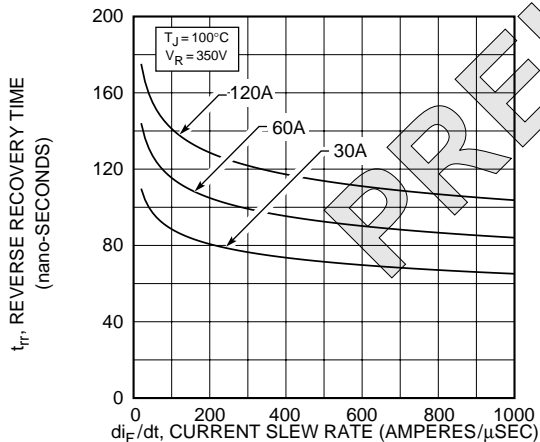

Figure 5, Reverse Recovery Time vs Current Slew Rate

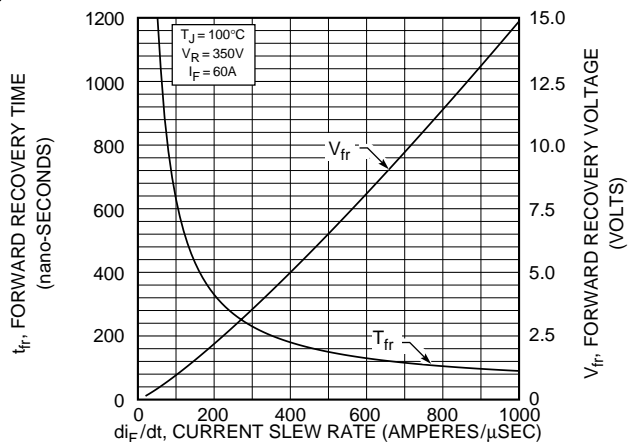

Figure 6, Forward Recovery Voltage/Time vs Current Slew Rate

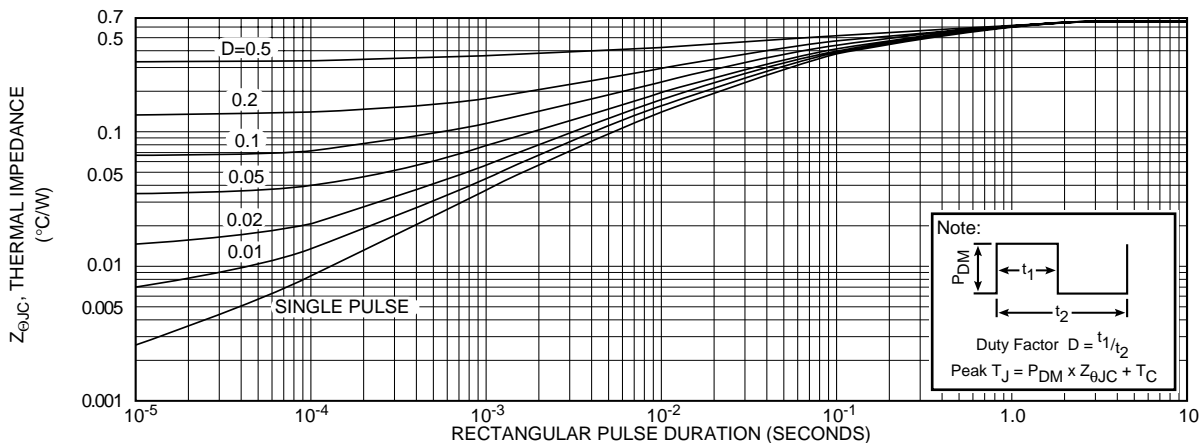

Figure 7, Maximum Effective Transient Thermal Impedance, Junction-To-Case vs Pulse Duration

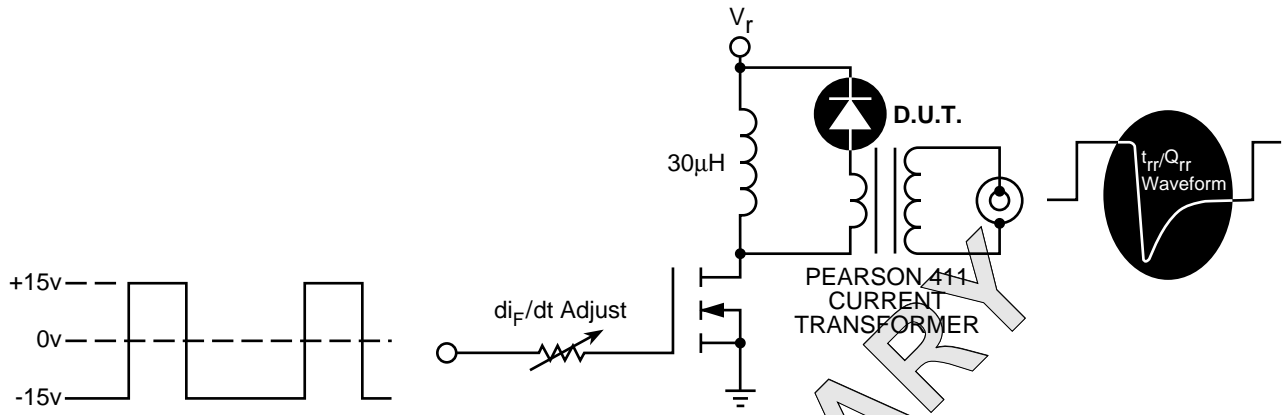

Figure 25, Diode Reverse Recovery Test Circuit and Waveforms

1 I_F - Forward Conduction Current

2 di_F/dt - Current Slew Rate, Rate of Forward Current Change Through Zero Crossing

3 I_{RRM} - Peak Reverse Recovery Current.

4 t_{rr} - Reverse Recovery Time Measured from Point of I_F Current Falling Through Zero to a Tangent Line { 6 diM/dt } Extrapolated Through Zero Defined by 0.75 and 0.50 I_{RRM} .

5 Q_{rr} - Area Under the Curve Defined by I_{RRM} and t_{rr} .

6 diM/dt - Maximum Rate of Current Change During the Trailing Portion of t_{rr} .

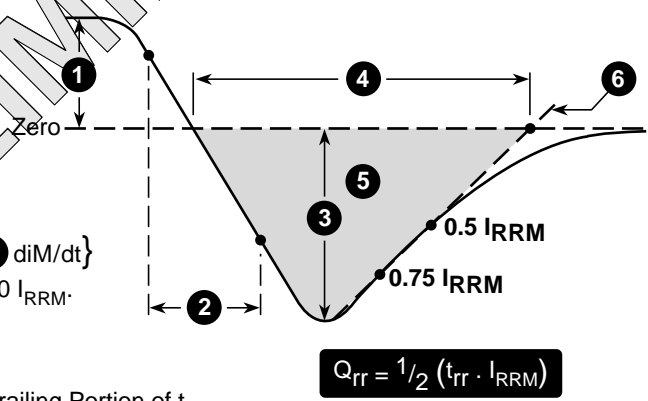
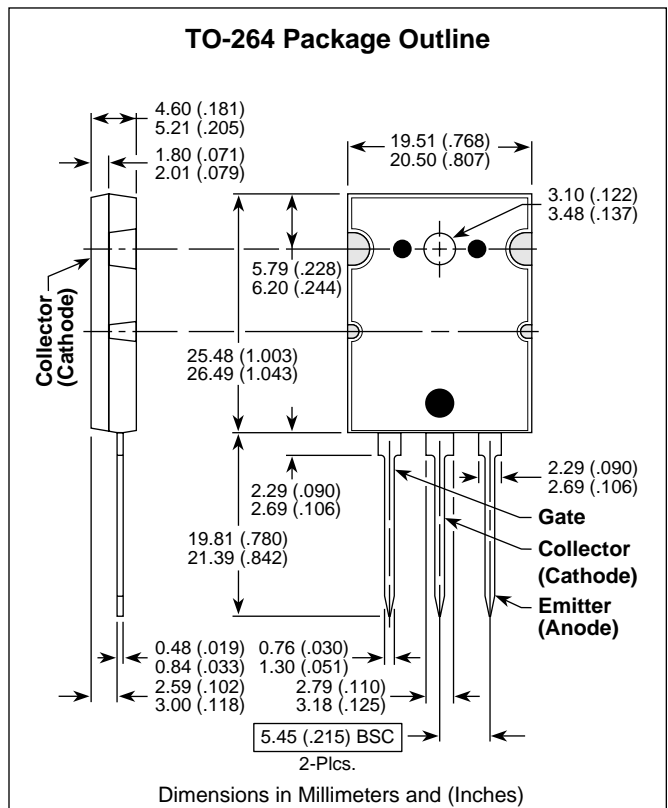
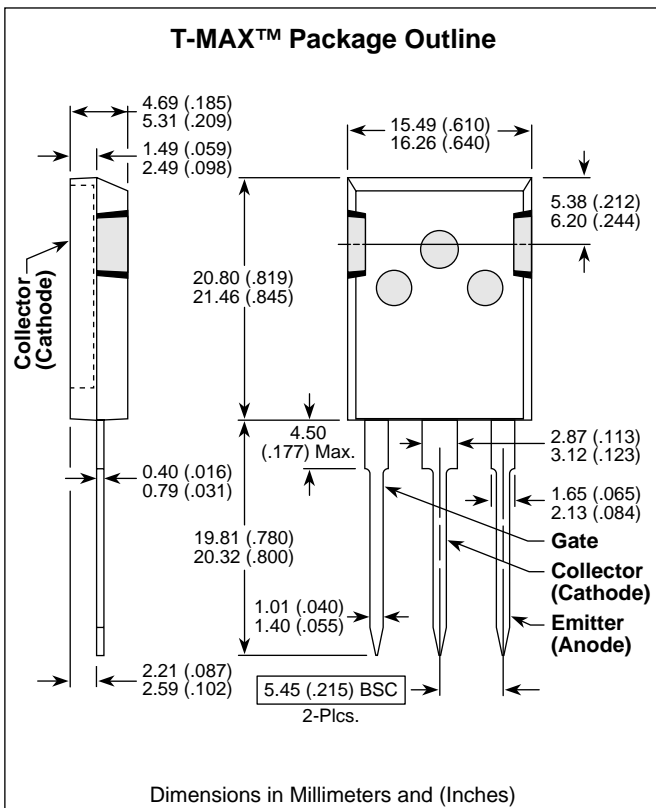

Figure 8, Diode Reverse Recovery Waveform and Definitions





LittleDiode supplies new, hard to find or obsolete electronic components and semiconductors all over the world.

With over two million different components listed you are sure to find the part you need.

Feel free to visit us today at our online store:

LittleDiode.com

Looking forward to providing you with the best possible service.