

### Fast IGBT

The Fast IGBT is a new generation of high voltage power IGBTs. Using Non-Punch Through Technology the Fast IGBT offers superior ruggedness, fast switching speed and low Collector-Emitter On voltage.

- Low Forward Voltage Drop
- Low Tail Current
- Avalanche Rated
- High Freq. Switching to 20KHz
- Ultra Low Leakage Current
- RBSOA and SCSOA Rated

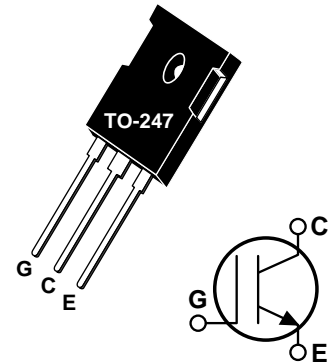

#### MAXIMUM RATINGS

All Ratings:  $T_C = 25^\circ\text{C}$  unless otherwise specified.

Symbol	Parameter	APT50GF60BR	UNIT
$V_{CES}$	Collector-Emitter Voltage	600	Volts
$V_{CGR}$	Collector-Gate Voltage ( $R_{GE} = 20K\Omega$ )	600	
$V_{GE}$	Gate-Emitter Voltage	$\pm 20$	
$I_{C1}$	Continuous Collector Current @ $T_C = 25^\circ\text{C}$	75	Amps
$I_{C2}$	Continuous Collector Current @ $T_C = 90^\circ\text{C}$	50	
$I_{CM}$	Pulsed Collector Current <sup>①</sup> @ $T_C = 25^\circ\text{C}$	160	
$I_{LM}$	RBSOA Clamped Inductive Load Current @ $R_g = 11\Omega$ $T_C = 125^\circ\text{C}$	100	
$E_{AS}$	Single Pulse Avalanche Energy <sup>②</sup>	75	mJ
$P_D$	Total Power Dissipation	300	Watts
$T_J, T_{STG}$	Operating and Storage Junction Temperature Range	-55 to 150	$^\circ\text{C}$
$T_L$	Max. Lead Temp. for Soldering: 0.063" from Case for 10 Sec.	300	

#### STATIC ELECTRICAL CHARACTERISTICS

Symbol	Characteristic / Test Conditions	MIN	TYP	MAX	UNIT
$BV_{CES}$	Collector-Emitter Breakdown Voltage ( $V_{GE} = 0V, I_C = 1.0mA$ )	600			Volts
$V_{GE(TH)}$	Gate Threshold Voltage ( $V_{CE} = V_{GE}, I_C = 700\mu A, T_j = 25^\circ\text{C}$ )	4.5	5.5	6.5	
$V_{CE(ON)}$	Collector-Emitter On Voltage ( $V_{GE} = 15V, I_C = 50A, T_j = 25^\circ\text{C}$ )		2.1	2.7	
	Collector-Emitter On Voltage ( $V_{GE} = 15V, I_C = 50A, T_j = 125^\circ\text{C}$ )		2.2	2.8	
$I_{CES}$	Collector Cut-off Current ( $V_{CE} = V_{CES}, V_{GE} = 0V, T_j = 25^\circ\text{C}$ )			0.5	mA
	Collector Cut-off Current ( $V_{CE} = V_{CES}, V_{GE} = 0V, T_j = 125^\circ\text{C}$ )			5.0	
$I_{GES}$	Gate-Emitter Leakage Current ( $V_{GE} = \pm 20V, V_{CE} = 0V$ )			$\pm 100$	nA

 **CAUTION:** These Devices are Sensitive to Electrostatic Discharge. Proper Handling Procedures Should Be Followed.

APT Website - <http://www.advancedpower.com>

## DYNAMIC CHARACTERISTICS

APT50GF60BR

Symbol	Characteristic	Test Conditions	MIN	TYP	MAX	UNIT
$C_{ies}$	Input Capacitance	<b>Capacitance</b> $V_{GE} = 0V$ $V_{CE} = 25V$ $f = 1\text{ MHz}$		2250		pF
$C_{oes}$	Output Capacitance			255		
$C_{res}$	Reverse Transfer Capacitance			155		
$Q_g$	Total Gate Charge <sup>③</sup>	<b>Gate Charge</b> $V_{GE} = 15V$ $V_{CC} = 0.66V_{CES}$ $I_C = I_{C2}$		175		nC
$Q_{ge}$	Gate-Emitter Charge			18		
$Q_{gc}$	Gate-Collector ("Miller") Charge			100		
$t_{d(on)}$	Turn-on Delay Time	<b>Resistive Switching (25°C)</b> $V_{GE} = 15V$ $V_{CC} = 0.66V_{CES}$ $I_C = I_{C2}$ $R_G = 10\Omega$		29		ns
$t_r$	Rise Time			118		
$t_{d(off)}$	Turn-off Delay Time			150		
$t_f$	Fall Time			190		
$t_{d(on)}$	Turn-on Delay Time	<b>Inductive Switching (150°C)</b> $V_{CLAMP(Peak)} = 0.66V_{CES}$ $V_{GE} = 15V$ $I_C = I_{C2}$ $R_G = 10\Omega$ $T_J = +150^\circ C$		28		ns
$t_r$	Rise Time			75		
$t_{d(off)}$	Turn-off Delay Time			265		
$t_f$	Fall Time			185		
$E_{on}$	Turn-on Switching Energy	$R_G = 10\Omega$ $T_J = +150^\circ C$		1.8		mJ
$E_{off}$	Turn-off Switching Energy			2.4		
$E_{ts}$	Total Switching Losses			4.2		
$t_{d(on)}$	Turn-on Delay Time	<b>Inductive Switching (25°C)</b> $V_{CLAMP(Peak)} = 0.66V_{CES}$ $V_{GE} = 15V$ $I_C = I_{C2}$ $R_G = 10\Omega$ $T_J = +25^\circ C$		30		ns
$t_r$	Rise Time			80		
$t_{d(off)}$	Turn-off Delay Time			240		
$t_f$	Fall Time			43		
$E_{ts}$	Total Switching Losses			3.6		
$g_{fe}$	Forward Transconductance	$V_{CE} = 20V, I_C = I_{C2}$	6			S

## THERMAL AND MECHANICAL CHARACTERISTICS

Symbol	Characteristic	MIN	TYP	MAX	UNIT
$R_{\theta JC}$	Junction to Case			0.42	°C/W
$R_{\theta JA}$	Junction to Ambient			40	
$W_T$	Package Weight		0.22		oz
			6.1		gm
Torque	Mounting Torque (using a 6-32 or 3mm Binding Head Machine Screw)			10	lb•in
				1.1	N•m

① Repetitive Rating: Pulse width limited by maximum junction temperature.

②  $I_C = I_{C2}$ ,  $R_{GE} = 25\Omega$ ,  $L = 100\mu H$ ,  $T_J = 25^\circ C$

③ See MIL-STD-750 Method 3471

APT Reserves the right to change, without notice, the specifications and information contained herein.

**APT50GF60BR**

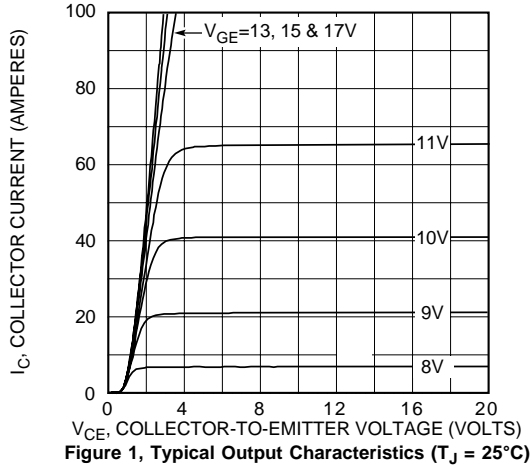

**Figure 1, Typical Output Characteristics ( $T_J = 25^\circ\text{C}$ )**

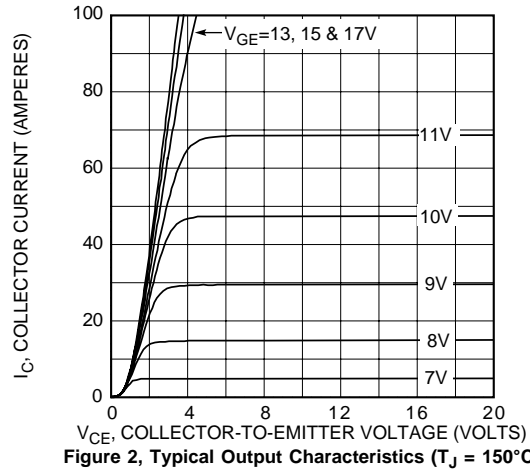

**Figure 2, Typical Output Characteristics ( $T_J = 150^\circ\text{C}$ )**

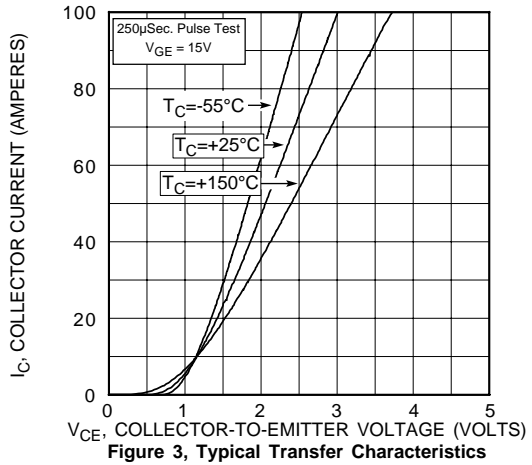

**Figure 3, Typical Transfer Characteristics**

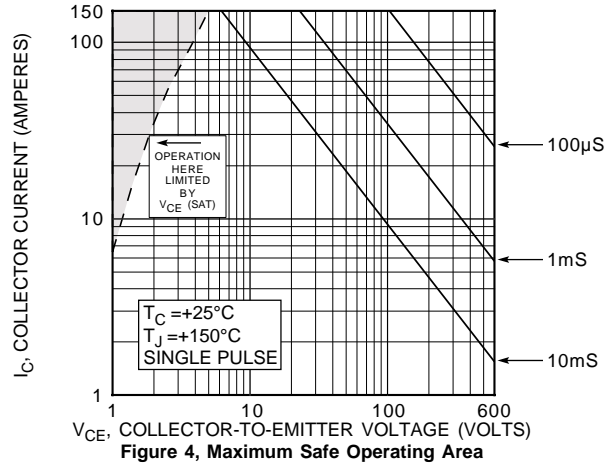

**Figure 4, Maximum Safe Operating Area**

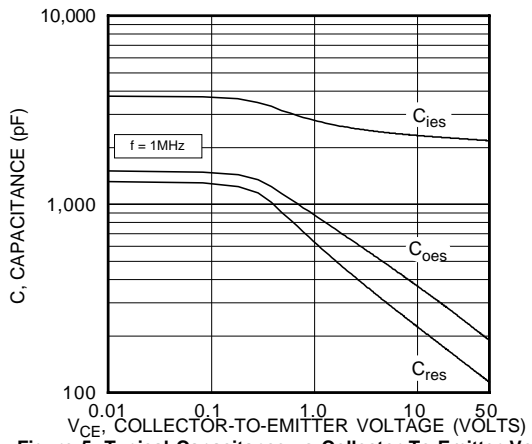

**Figure 5, Typical Capacitance vs Collector-To-Emitter Voltage**

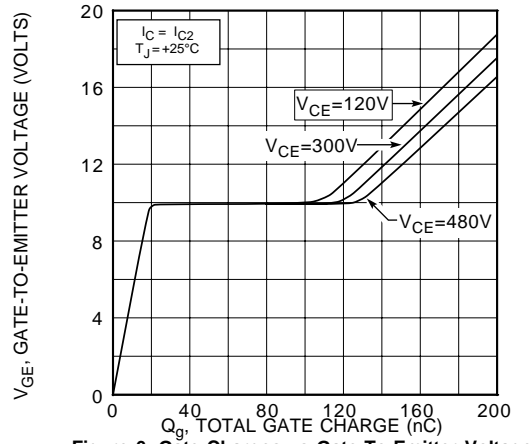

**Figure 6, Gate Charges vs Gate-To-Emitter Voltage**

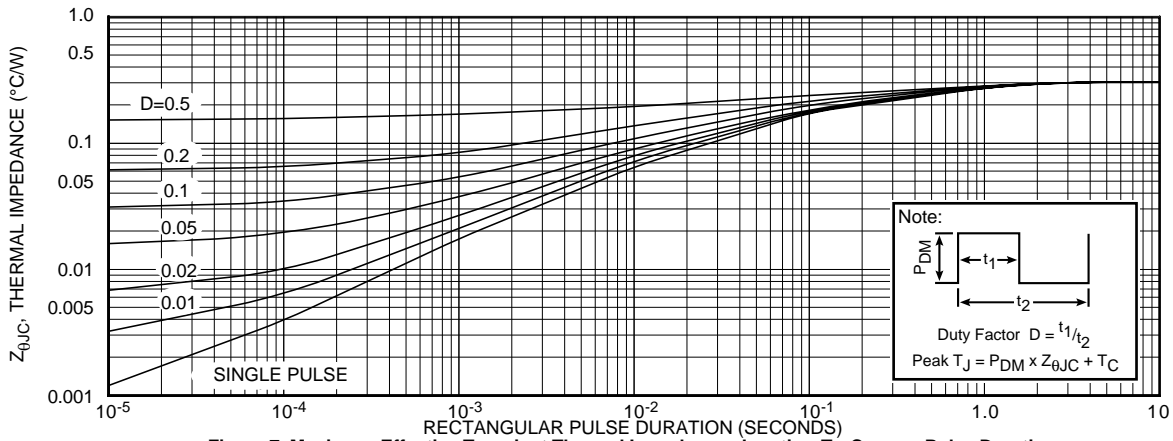

**Figure 7, Maximum Effective Transient Thermal Impedance, Junction-To-Case vs Pulse Duration**

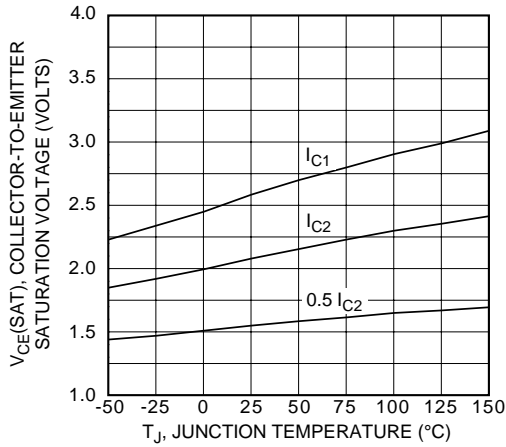

Figure 8, Typical  $V_{CE(SAT)}$  Voltage vs Junction Temperature

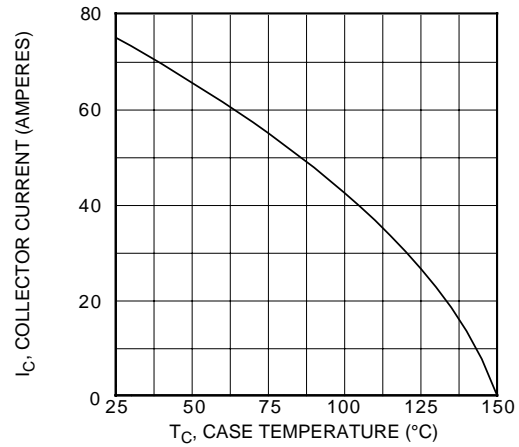

Figure 9, Maximum Collector Current vs Case Temperature

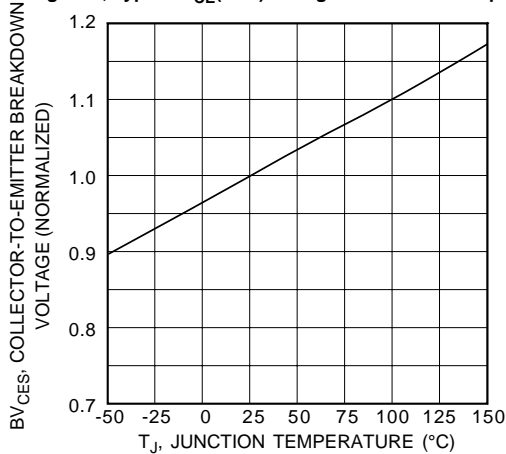

Figure 10, Breakdown Voltage vs Junction Temperature

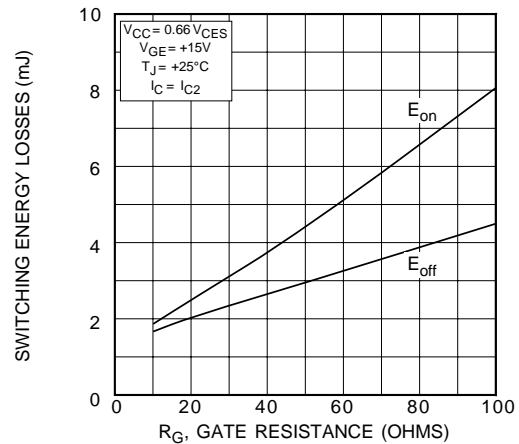

Figure 11, Typical Switching Energy Losses vs Gate Resistance

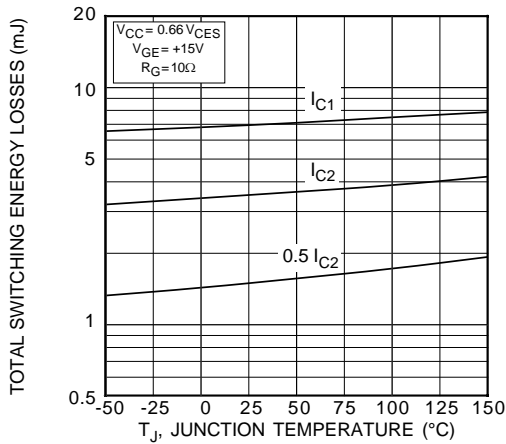

Figure 12, Typical Switching Energy Losses vs. Junction Temperature

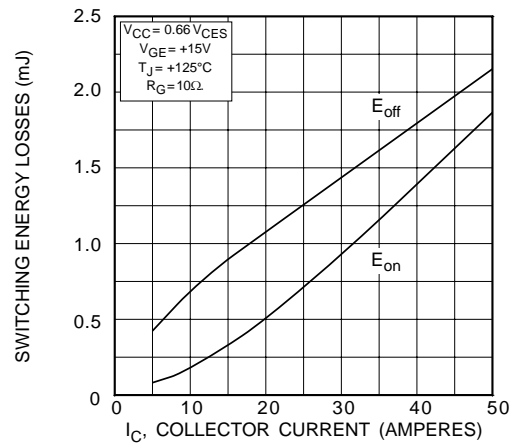

Figure 13, Typical Switching Energy Losses vs Collector Current

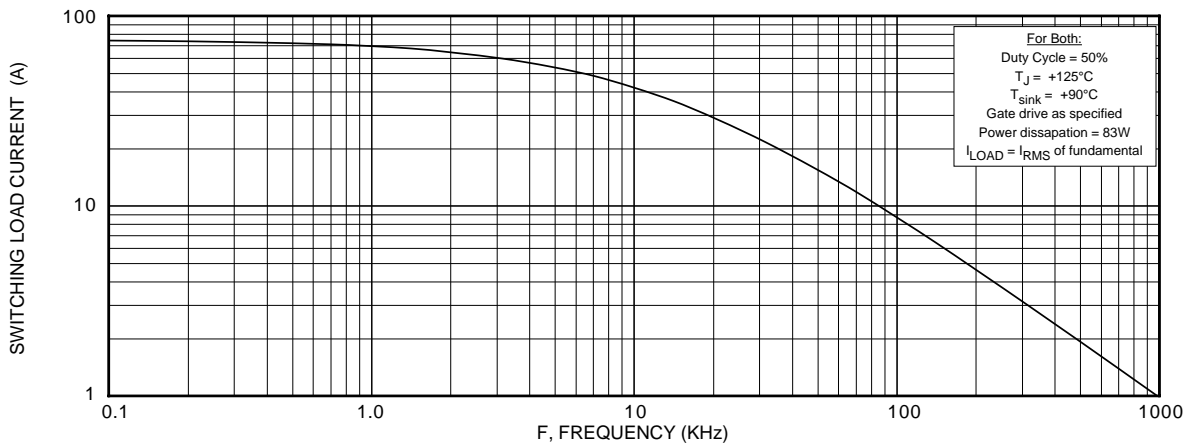

Figure 14, Typical Load Current vs Frequency

# APT50GF60BR

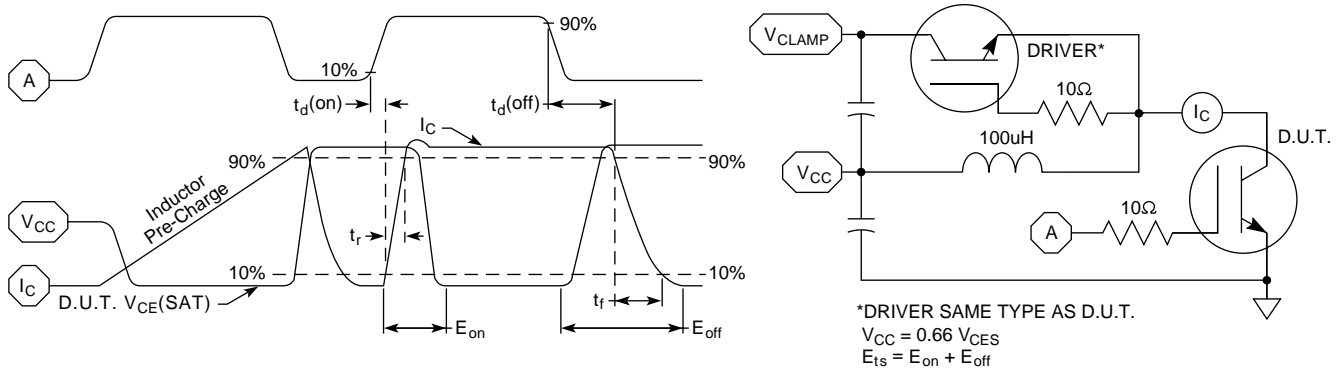

Figure 16, Switching Loss Test Circuit and Waveforms

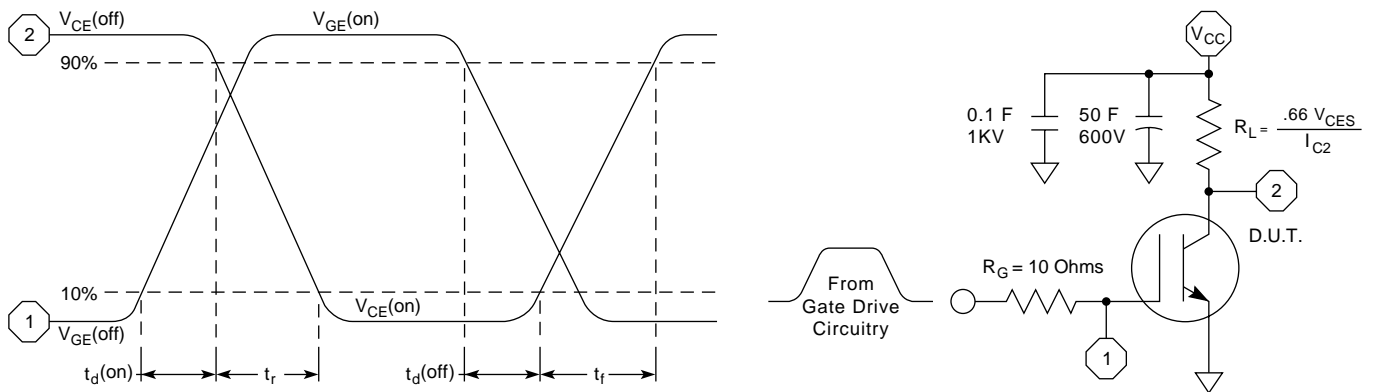
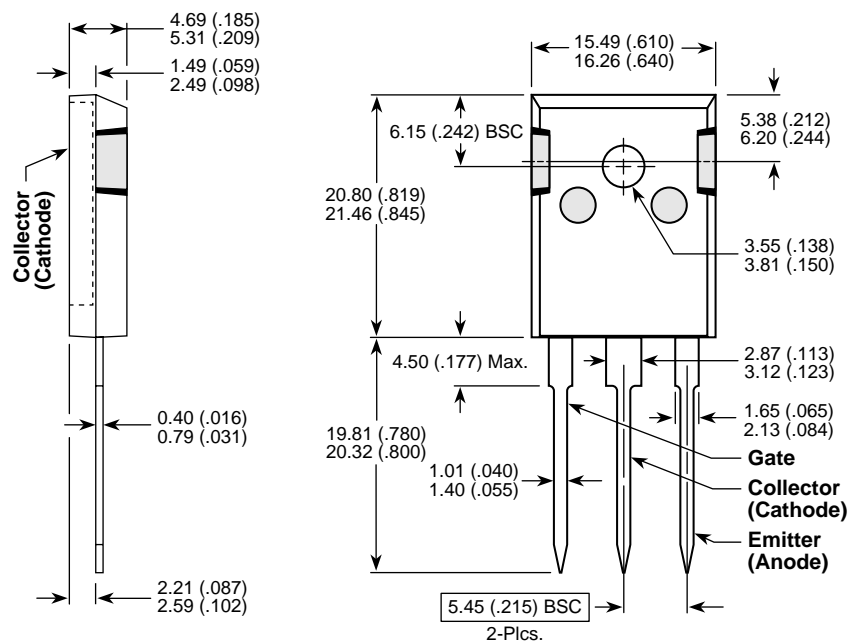

Figure 17, Resistive Switching Time Test Circuit and Waveforms

## T0-247 Package Outline



Dimensions in Millimeters and (Inches)



LittleDiode supplies new, hard to find or obsolete electronic components and semiconductors all over the world.

With over two million different components listed you are sure to find the part you need.

Feel free to visit us today at our online store:

[LittleDiode.com](http://LittleDiode.com)

Looking forward to providing you with the best possible service.