

CR10C

MEDIUM POWER USE
NON-INSULATED TYPE, GLASS PASSIVATION TYPE

CR10C



- **IT (AV)** **10A**
- **VDRM** **400V/600V/800V**
- **IGT** **30mA**

OUTLINE DRAWING Dimensions
in mm

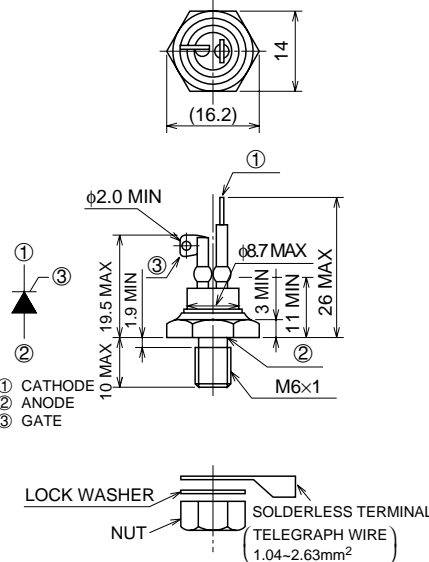

① CATHODE
② ANODE
③ GATE

LOCK WASHER
NUT
SOLDERLESS TERMINAL (TELEGRAPH WIRE) (1.04~2.63mm²)

Note: Mica washer and spacer are provided only upon request.

APPLICATION

DC motor control, electric furnace control, static switches, DC supply

MAXIMUM RATINGS

Symbol	Parameter	Voltage class			Unit
		8	12	16	
VRRM	Repetitive peak reverse voltage	400	600	800	V
VRSM	Non-repetitive peak reverse voltage	500	720	960	V
VDRM	Repetitive peak off-state voltage	400	600	800	V

Symbol	Parameter	Conditions	Ratings	Unit
IT (RMS)	RMS on-state current		15.5	A
IT (AV)	Average on-state current	Commercial frequency, sine half wave, 180° conduction, Tc=84°C	10	A
ITSM	Surge on-state current	60Hz sine half wave 1 full cycle, peak value, non-repetitive	200	A
i ² _t	i ² _t for fusing	Value corresponding to 1 cycle of half wave 60Hz, surge on-state current	165	A ² s
di/dt	Critical rate of rise of on-state current	VD=1/2VDRM, ITM=30A, IG=0.1A, Tj=25°C, f=60Hz	100	A/μs
PGM	Peak gate power dissipation		5.0	W
PG (AV)	Average gate power dissipation		0.5	W
VFGM	Peak gate forward voltage		10	V
VRGM	Peak gate reverse voltage		5	V
IFGM	Peak gate forward current		2	A
Tj	Junction temperature		-30 ~ +125	°C
Tstg	Storage temperature		-30 ~ +125	°C
—	Mounting torque		30	kg-cm
			2.94	N-cm
—	Weight	Typical value	8.8	g

CR10C

MEDIUM POWER USE
NON-INSULATED TYPE, GLASS PASSIVATION TYPE

ELECTRICAL CHARACTERISTICS

Symbol	Parameter	Test conditions	Limits			Unit
			Min.	Typ.	Max.	
IRRM	Repetitive peak reverse current	$T_j=125^\circ\text{C}$, V_{RRM} applied	—	—	3.0	mA
IDRM	Repetitive peak off-state current	$T_j=125^\circ\text{C}$, V_{DRM} applied	—	—	3.0	mA
V_{TM}	On-state voltage	$T_c=25^\circ\text{C}$, $I_{TM}=30\text{A}$, Instantaneous value	—	—	1.6	V
dv/dt	Critical-rate of rise of off-state voltage	$T_j=125^\circ\text{C}$, $V_D=2/3V_{DRM}$	20	—	—	V/ μs
VGT	Gate trigger voltage	$T_j=25^\circ\text{C}$, $V_D=6\text{V}$, $I_T=0.5\text{A}$	—	—	2.5	V
VGD	Gate non-trigger voltage	$T_j=125^\circ\text{C}$, $V_D=1/2V_{DRM}$	0.25	—	—	V
IGT	Gate trigger current	$T_j=25^\circ\text{C}$, $V_D=6\text{V}$, $I_T=0.5\text{A}$	—	—	30	mA
tgt	Turn-on time	$T_c=25^\circ\text{C}$, $V_D=100\text{V}$, $I_T=10\text{A}$, $I_G=0.1\text{A}$	—	—	10	μs
$R_{th(j-c)}$	Thermal resistance	Junction to case	—	—	2.0	$^\circ\text{C}/\text{W}$
$R_{th(j-c)}$	Contact thermal resistance	Case to fin, greased	—	—	0.55	$^\circ\text{C}/\text{W}$

PERFORMANCE CURVES

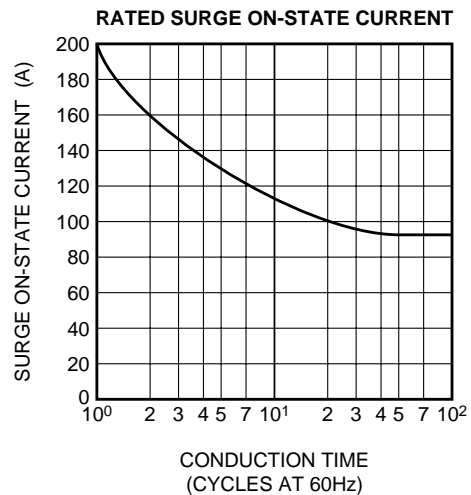
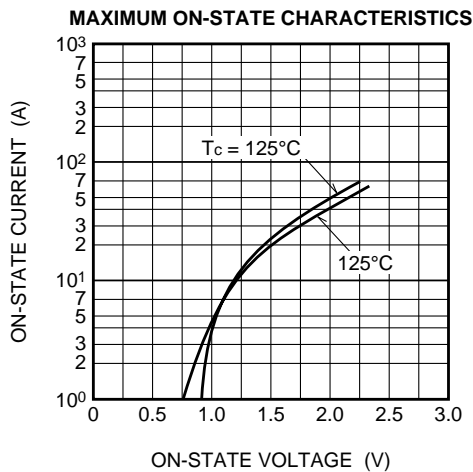

CR10C

MEDIUM POWER USE
NON-INSULATED TYPE, GLASS PASSIVATION TYPE

GATE CHARACTERISTICS

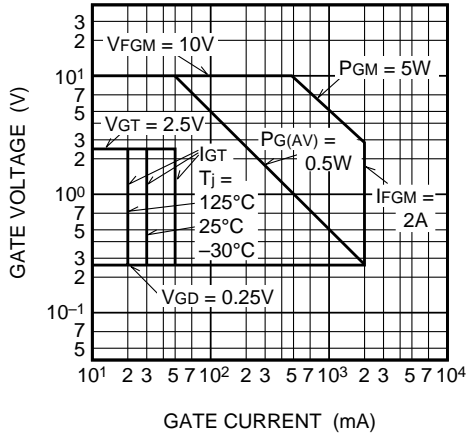

MAXIMUM TRANSIENT THERMAL IMPEDANCE CHARACTERISTICS (JUNCTION TO CASE)

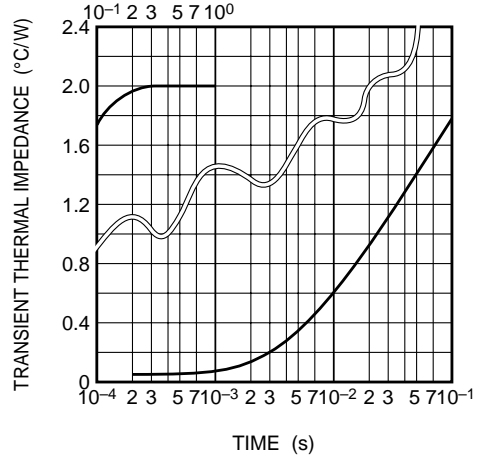

MAXIMUM AVERAGE POWER DISSIPATION (SINGLE-PHASE HALF WAVE)

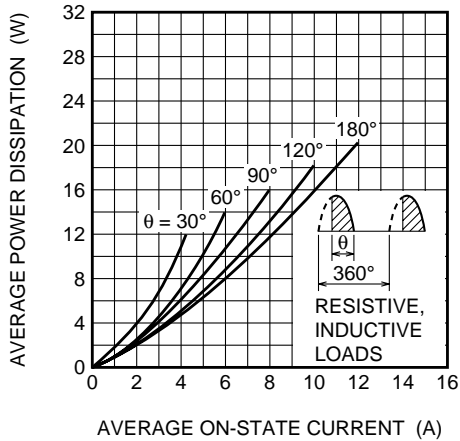

ALLOWABLE CASE TEMPERATURE VS. AVERAGE ON-STATE CURRENT (SINGLE-PHASE HALF WAVE)

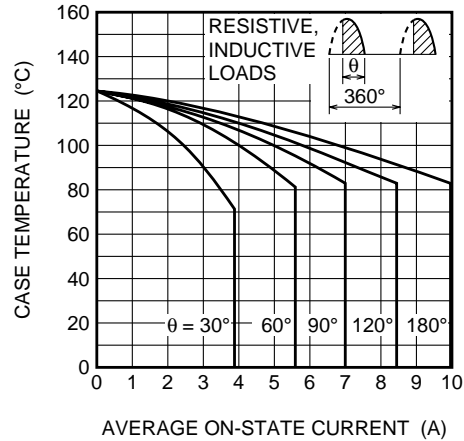

ALLOWABLE AMBIENT TEMPERATURE VS. AVERAGE ON-STATE CURRENT (SINGLE-PHASE HALF WAVE)

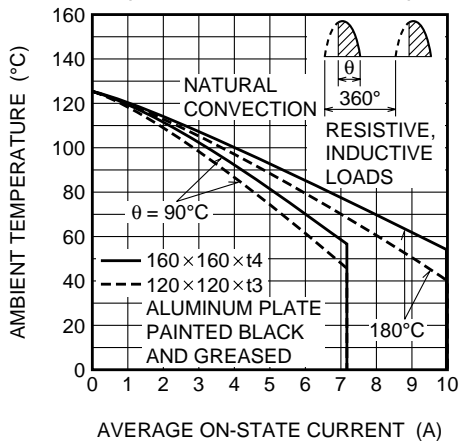

MAXIMUM AVERAGE POWER DISSIPATION (SINGLE-PHASE FULL WAVE)

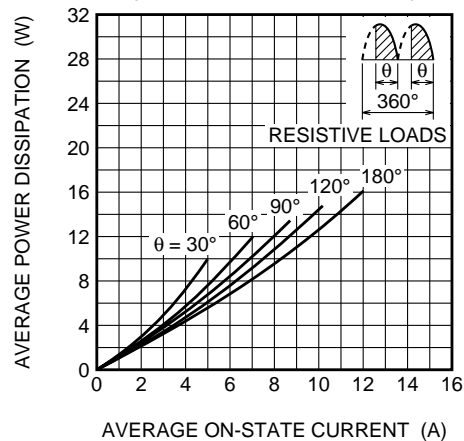

CR10C

MEDIUM POWER USE

NON-INSULATED TYPE, GLASS PASSIVATION TYPE

ALLOWABLE CASE TEMPERATURE VS. AVERAGE ON-STATE CURRENT (SINGLE-PHASE FULL WAVE)

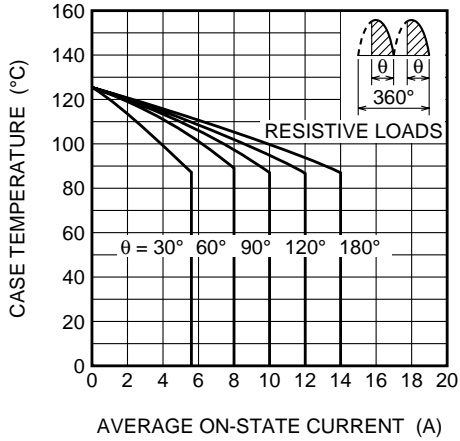

ALLOWABLE AMBIENT TEMPERATURE VS. AVERAGE ON-STATE CURRENT (SINGLE-PHASE FULL WAVE)

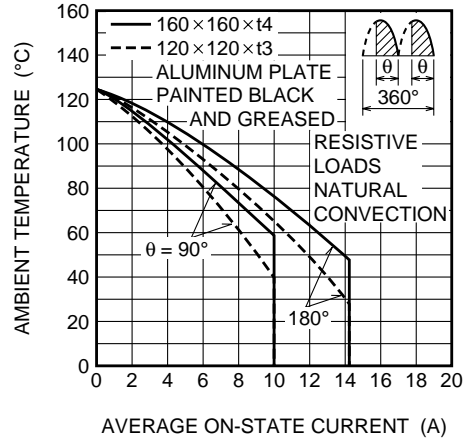

MAXIMUM AVERAGE POWER DISSIPATION (RECTANGULAR WAVE)

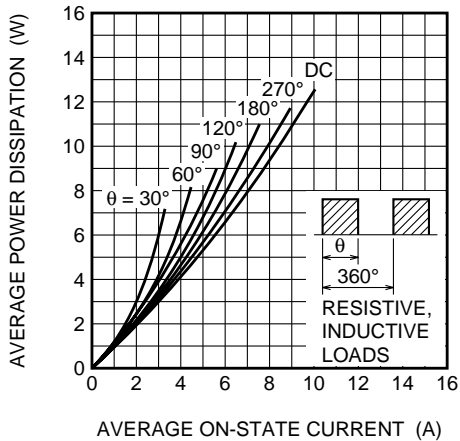

ALLOWABLE CASE TEMPERATURE VS. AVERAGE ON-STATE CURRENT (RECTANGULAR WAVE)

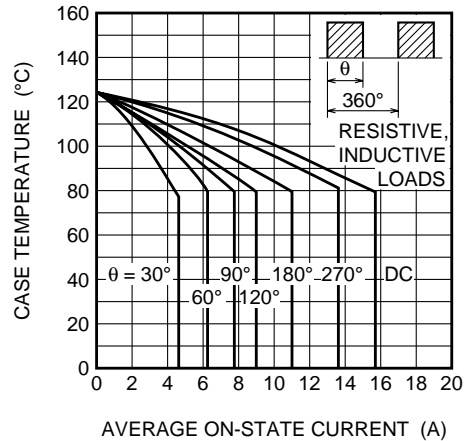

ALLOWABLE AMBIENT TEMPERATURE VS. AVERAGE ON-STATE CURRENT (RECTANGULAR WAVE)

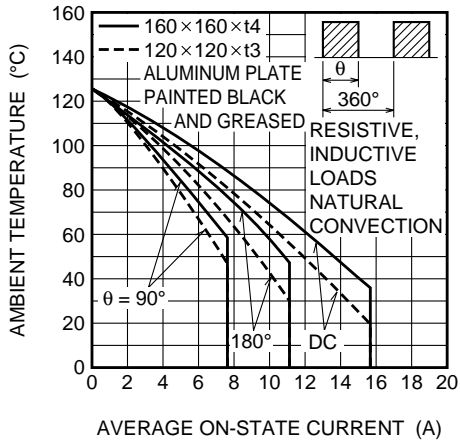

GATE TRIGGER CURRENT VS. GATE CURRENT PULSE WIDTH

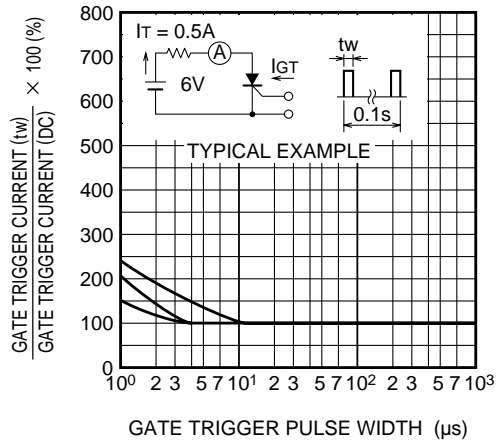



LittleDiode supplies new, hard to find or obsolete electronic components and semiconductors all over the world.

With over two million different components listed you are sure to find the part you need.

Feel free to visit us today at our online store:

LittleDiode.com

Looking forward to providing you with the best possible service.