



AS1004

Micropower Voltage Reference

Features

- Low voltage reference
- 10 μ A turn-on current for AS1004-1.2
- 20 μ A turn-on current for AS1004-2.5
- ± 4 mV (0.3 %) initial accuracy for AS1004-1.2
- ± 20 mV (0.8 %) initial accuracy for AS1004-2.5
- Guaranteed operation to 20 mA. Over three orders of magnitude of operating current!
- Temperature performance guaranteed
- Very low dynamic impedance

Description

The AS1004 is a two-terminal precision band-gap voltage reference with a low turn-on current of 10 μ A.

Emulating a 1.235 V zener diode, the AS1004 operates more than three orders of magnitude of output current with minute output impedance and guaranteed stability. With an initial tolerance of ± 4 mV and guaranteed temperature performance, it is ideal for precision instrumentation, especially in low power applications. Being a low-voltage reference, the AS1004 is also well-suited as a reference for low-voltage power supply applications, especially in power supplies intended for low-voltage logic systems, laptop computers and other portable or battery operated equipment.

The AS1004 is pin-for-pin compatible with the LT1004 and the LM385 and offers improved specifications over both the LM385 and the MP5010. It is also available as a 2.5 V reference with a guaranteed start-up current of 20 μ A.

Pin Configuration — Top view

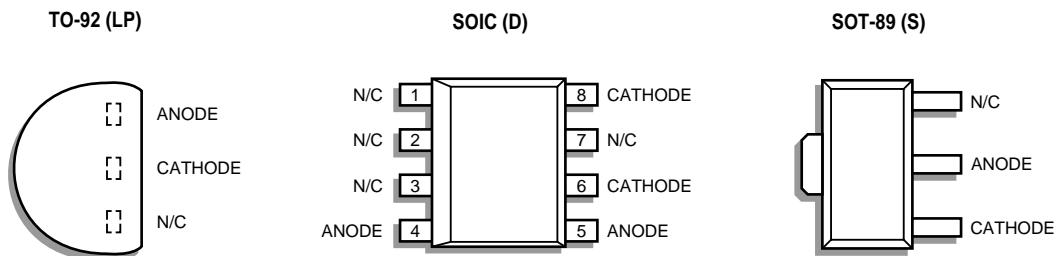

Ordering Information

Description	Temperature Range	Order Codes	
TO-92	0 to 70° C	AS1004-1.2LP	AS1004-2.5LP
8-Pin Plastic SOIC	0 to 70° C	AS1004-1.2D	AS1004-2.5D
SOT-89	0 to 70° C	AS1004-1.2S	AS1004-2.5S

Simplified Schematic

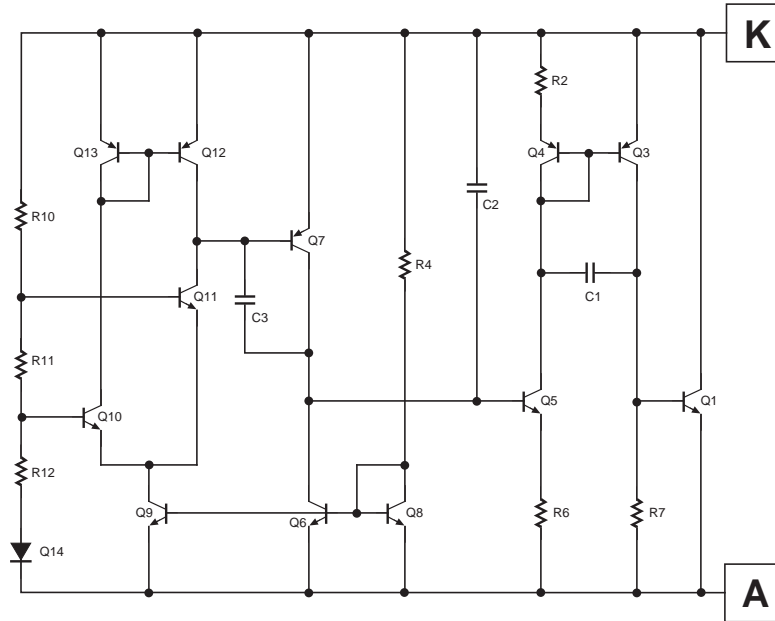

Absolute Maximum Ratings

Parameter	Symbol	Rating	Units
Reverse Breakdown Current	I_z	30	mA
Forward Current	I_F	30	mA
Continuous Power Dissipation at 25° C	P_D		
TO-92		775	mW
8LSOIC		750	mW
SOT-89		1000	mW
Maximum Junction Temp	T_J	150	°C
Storage Temperature	T_{STG}	-65 to 150	°C
Lead Temperature, Soldering 10 Seconds	T_L	300	°C

Recommended Conditions

Parameter	Symbol	Rating	Unit
Cathode Current	I_z	100	μA

Typical Thermal Resistances

Package	θ_{JA}	θ_{JC}	Typical Derating
TO-92	160° C/W	80° C/W	6.3 mW/°C
8L SOIC	175° C/W	45° C/W	5.7 mW/°C
SOT-89	110° C/W	8° C/W	9.1 mW/°C

Electrical Characteristics

Electrical Characteristics are guaranteed over full junction temperature range (0 to 70° C). Ambient temperature must be derated based on power dissipation and package thermal characteristics.

Parameter	Symbol	Test Condition	AS1004-1.2			AS1004-2.5			Unit
			Min	Typ	Max	Min	Typ	Max	
Reverse Breakdown Voltage	V _Z	I _Z = 100 μA, T _J = 25° C	1.231	1.235	1.239	2.480	2.500	2.520	V
		0° C ≤ T _A ≤ 70° C	1.225	1.235	1.245	2.470	2.500	2.530	V
Average Temperature Coefficient	ΔV _Z /ΔT	I _{min} ≤ I _Z ≤ 20 mA	20			60			ppm/°C
Minimum Operating Current	I _{Z (min)}		4 10			12 20			μA
Reverse Breakdown Voltage Change With Current	ΔV _Z /ΔI _Z	I _{min} ≤ I _Z ≤ 1 mA	0.5 1			0.5 1			mV
		Over Temperature	0.5 1.5			0.5 1.5			mV
		1 mA ≤ I _Z ≤ 20 mA	6.5 10			6.5 10			mV
		Over Temperature	6.5 20			6.5 20			mV
Reverse Dynamic Impedance	Z _Z	I _Z = 100 mA, f = 25 Hz	0.2 0.6			0.8 0.9			Ω
		Over Temperature	1 1.5			1.5			Ω
Wide Band Noise	e _n	I _Z = 100 μA 10 Hz ≤ f ≤ 10 KHz	60			60			μV
Long Term Stability	ΔV _Z /ΔT	I _Z = 100 μA T _A = 25° C ± 0.1° C	20			60			ppm/kH

Typical Performance Curves

Calculating Average Temperature Coefficient for the AS1004-1.2 Reference

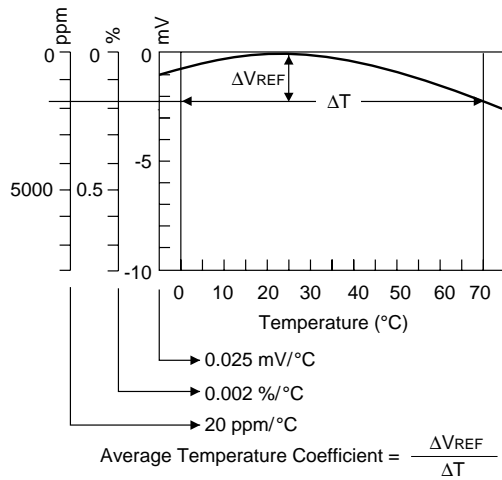

Figure 1

AS1004-1.2 Reference Voltage vs. Ambient Temperature

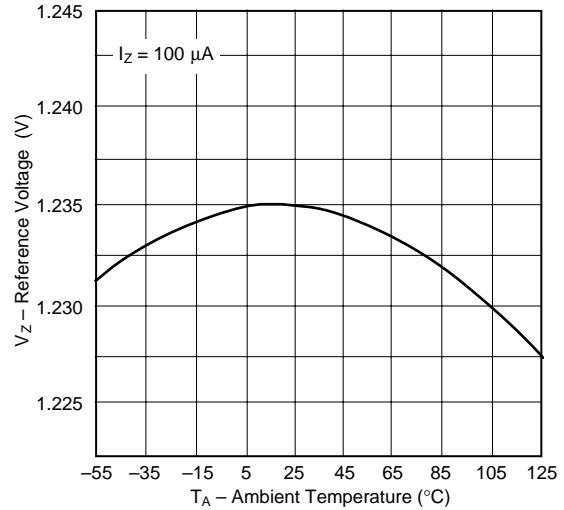

Figure 2

Typical Performance Curves

Calculating Average Temperature Coefficient for the AS1004-2.5 Reference

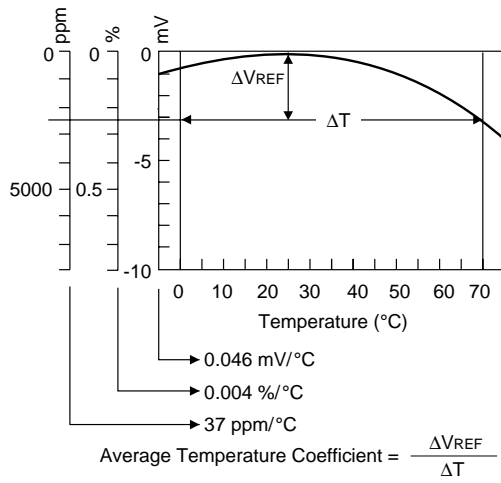

Figure 3

AS1004-2.5 Reference Voltage versus Ambient Temperature

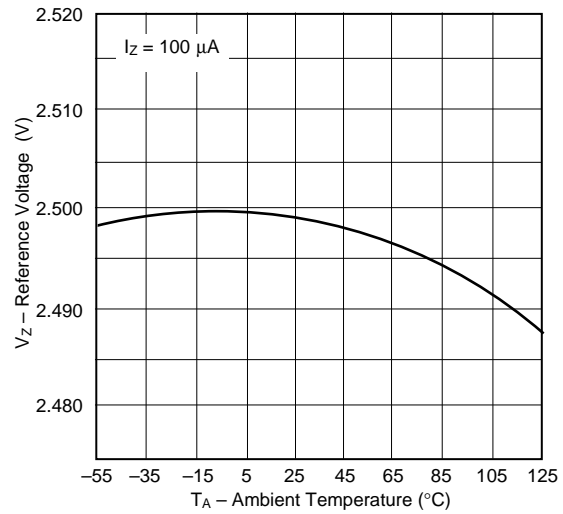

Figure 4

AS1004-1.2 Reverse Operating Characteristics

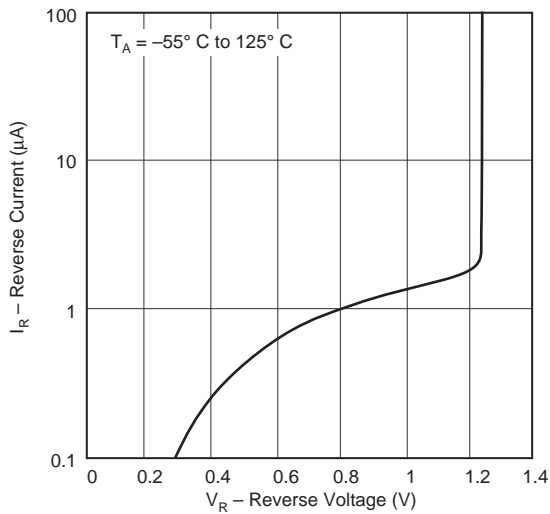

Figure 5

AS1004-2.5 Reverse Operating Characteristics

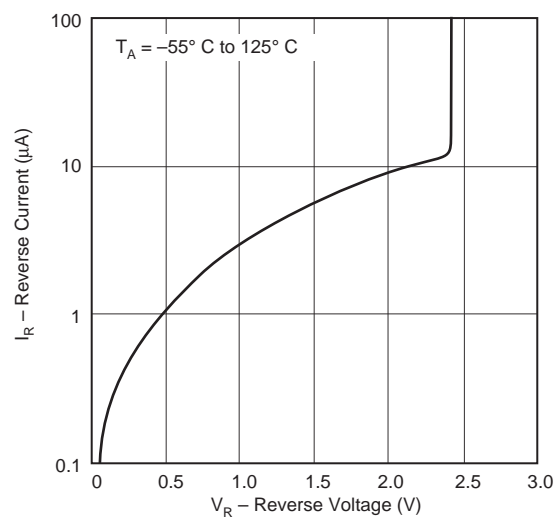

Figure 6

Typical Performance Curves

AS1004-1.2 Change in Reference Voltage versus Reverse Current

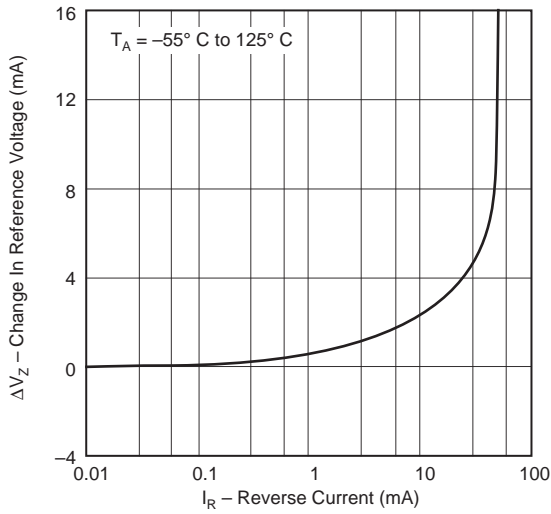

Figure 7

AS1004-2.5 Change in Reference Voltage versus Reverse Current

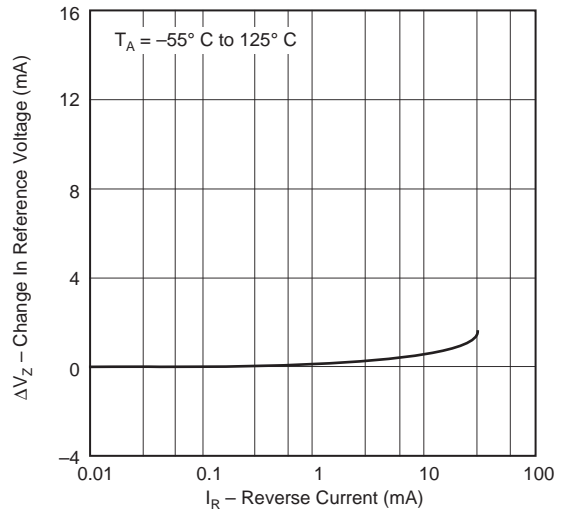

Figure 8

AS1004-1.2 Transient Response

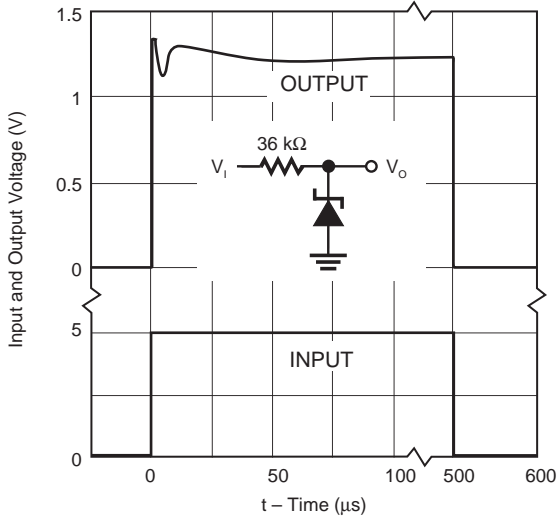

Figure 9

AS1004-2.5 Transient Response

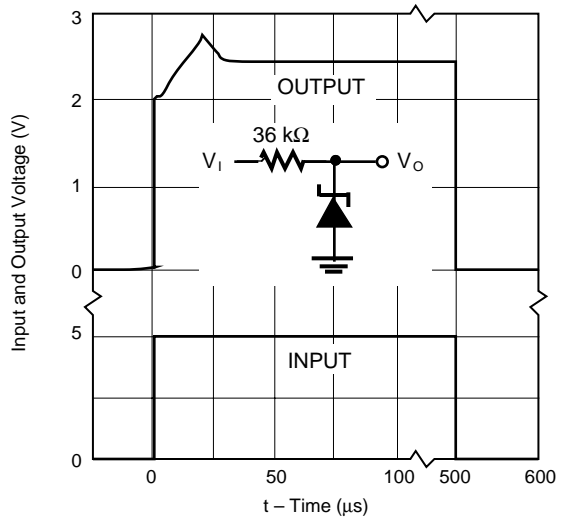

Figure 10

Typical Performance Curves

AS1004-1.2 Reverse Dynamic Impedance

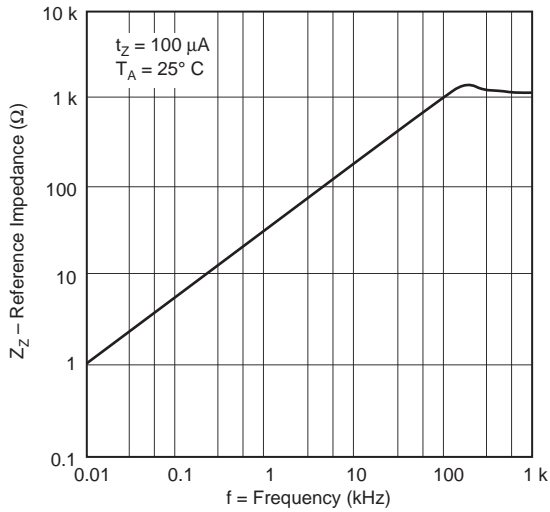

Figure 11

AS1004-2.5 Reverse Dynamic Impedance

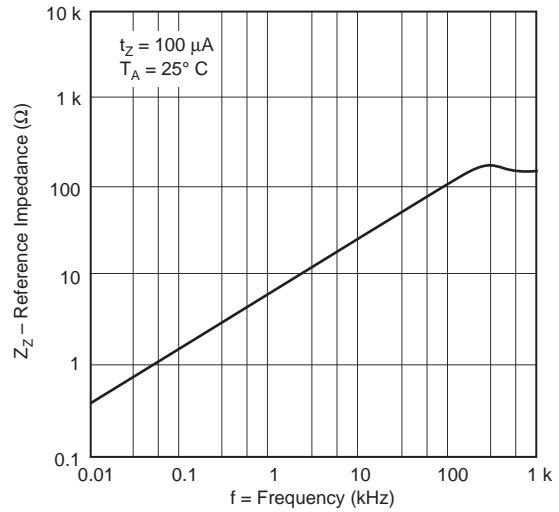

Figure 12

Forward Characteristics

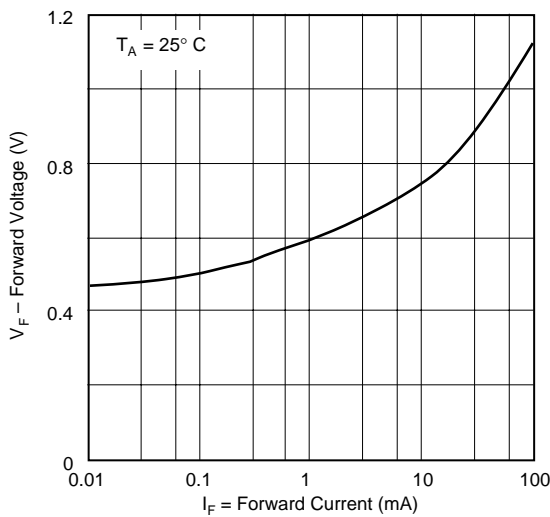

Figure 13

Low Frequency Reverse Dynamic Impedance

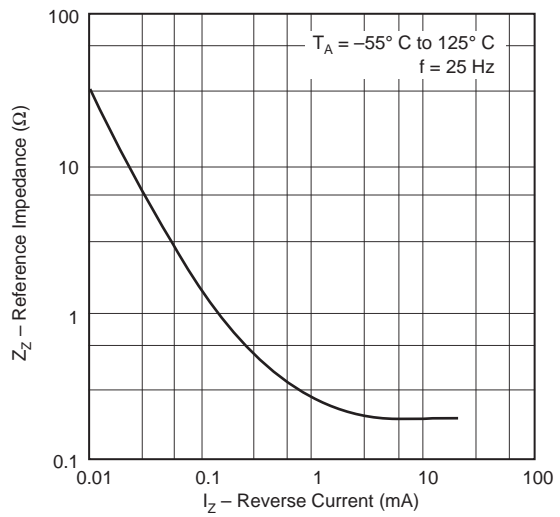

Figure 14

Typical Applications

1.235V Reference

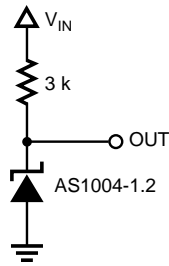

Figure 15

2.5V Reference

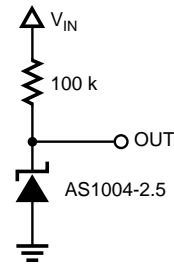

Figure 16

Low Noise Reference

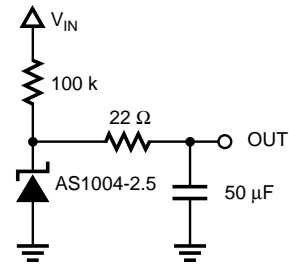

Figure 17

Variable Output Regulator

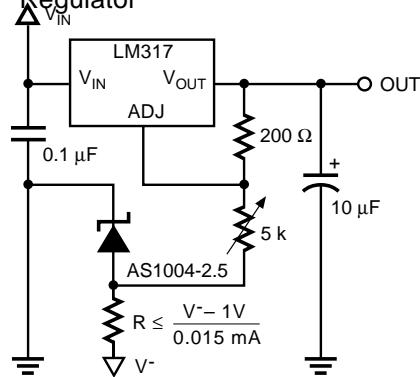

Figure 18

High Stability 5V Regulator

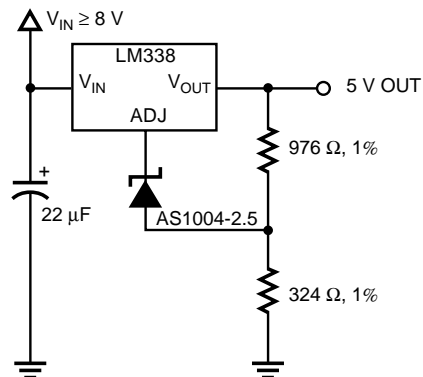

Figure 19

Lead Acid Low Battery Detector

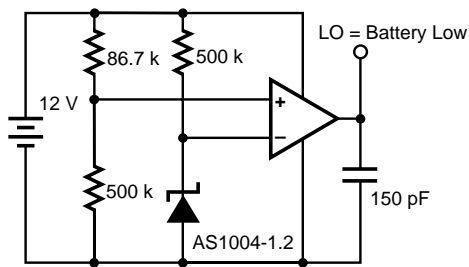

Figure 20

Micropower 10V Reference

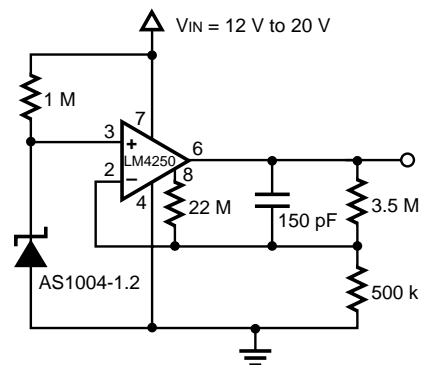

Figure 21

Notes



LittleDiode supplies new, hard to find or obsolete electronic components and semiconductors all over the world.

With over two million different components listed you are sure to find the part you need.

Feel free to visit us today at our online store:

LittleDiode.com

Looking forward to providing you with the best possible service.