

Features

- Programmable to three different over-temperature thresholds
- 2.5 V temperature compensated bandgap reference trimmed to 1%
- Open collector output goes low on over-temp condition
- $\pm 3^{\circ}\text{C}$ temperature accuracy
- Reference shunt current serves to program over-temp threshold
- Available with 5°C or 10°C of temperature hysteresis
- Available in a wide range of over-temp thresholds to fit most temperature monitoring applications
- Now available in the SOT-223 for improved substrate temperature sensing

Description

The AS273 is a series of programmable over-temperature detectors. Each is internally composed of a precision 2.5 V shunt reference, a proportional-to-absolute temperature thermal sensor, a comparator with controlled hysteresis, and an open collector output that indicates an over-temp condition. The threshold for the over-temp signal can be set to any of three values on a given part by controlling the magnitude of the reference shunt current.

The AS273 has an excellent absolute temperature accuracy of $\pm 3^{\circ}\text{C}$ for each of the three over-temp thresholds. The low power dissipation minimizes any temperature sensing errors due to self-heating. There is either 5°C or 10°C of temperature hysteresis to prevent bouncing when an over-temp condition is removed.

The packaging options available with the AS273 make it appealing to a wide variety of temperature-sensing applications. The TO-92 package can be mechanically clamped to a heat sink to monitor the temperature of power devices. The 8L-SOIC and SOT-223 surface mount packages allow for temperature sensing in high component density applications.

Pin Configuration — Top view

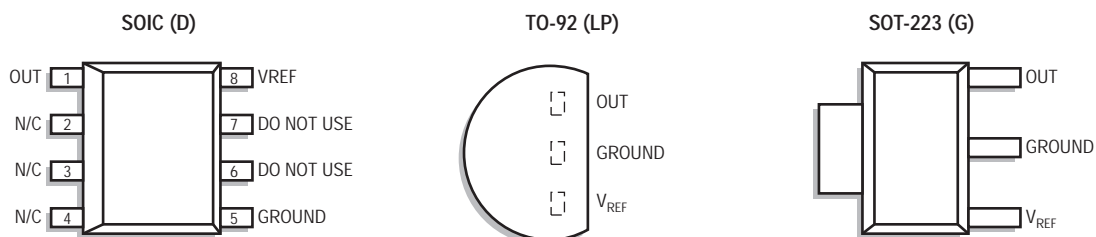

Ordering Information

Circuit Type: AS273 Over-Temperature Detector

Temperature Option: D (Refer to Table A)

Table A – Temperature Options

Code	T _{OT1}	T _{OT2}	T _{OT3}
D	40	45	50
F	75	80	85
G	90	95	100
H	105	110	115

AS273 D 1 D A

Packaging Option:
 A = Ammo Pack
 B = Bulk
 T = Tube
 13 = Tape and Reel (13" Reel Dia)

Package Style:
 D = SOIC
 G = SOT-223
 LP = TO-92

Hysteresis Option:
 1 = 10°C
 5 = 5°C

Functional Block Diagram

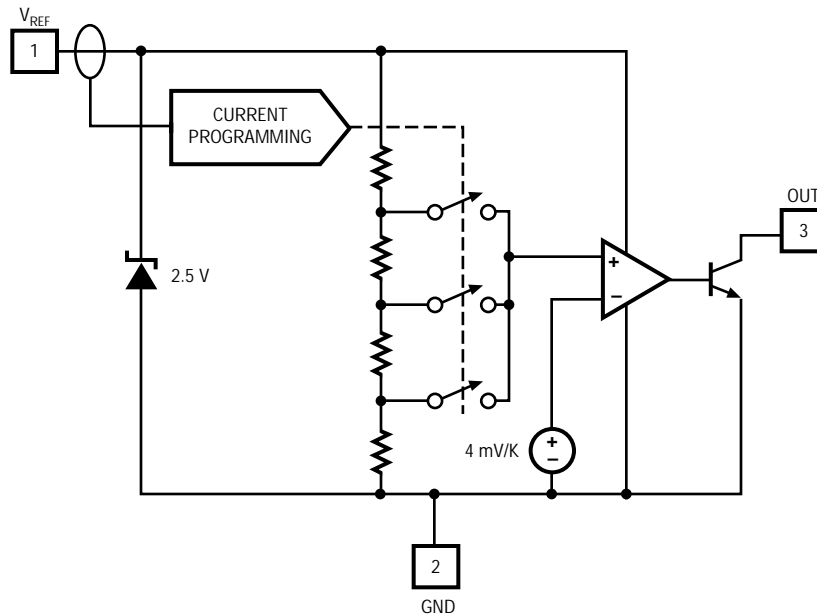

Pin Function Description

Pin Number	Function	Description
1	V _{REF}	2.5 V shunt reference; current into V _{REF} pin also programs over-temperature trip point to one of three T _{OT} values
2	GND	Circuit ground and silicon substrate
3	OUT	Open collector output. Output low when die temperature exceeds programmed trip point

Absolute Maximum Ratings

Parameter	Symbol	Rating	Unit
Reference Current	V_{REF}	± 10	mA
Output Current	I_{OUT}	± 10	mA
Output Voltage	V_{OUT}	18	V
Continuous Power Dissipation at 25°C			
TO-92	P_D	775	mW
8-SOIC	P_D	750	mW
SOT-223	P_D	1000	mW
Junction Temperature	T_J	150	°C
Storage Temperature	T_{STG}	-65 to 150	°C
Lead Temp, Soldering 10 Seconds	T_L	300	°C

Stresses greater than those listed under ABSOLUTE MAXIMUM RATINGS may cause permanent damage to the device. This is a stress rating only and functional operation of the device at these or any other conditions above those indicated in the operational sections of this specification is not implied. Exposure to absolute maximum rating conditions for extended periods may affect reliability.

Typical Thermal Resistances

Package	θ_{JA}	θ_{JC}	Typical Derating
SOT-223	115°C/W	8°C/W	8.7 mW/°C
TO-92	160°C/W	80°C/W	6.3 mW/°C
8L SOIC	175°C/W	45°C/W	5.7 mW/°C

Electrical Characteristics

Electrical Characteristics are guaranteed over the full junction temperature range (0 to 125°C). Ambient temperature must be derated based upon power dissipation and package thermal characteristics.

Parameter	Symbol	Test Condition	Min.	Typ.	Max.	Unit
Reference						
Reference Voltage	V_{REF}	$I_{REF} = 2 \text{ mA}$, $T_J = 25^\circ\text{C}$	2.500	2.525	2.550	V
Load Regulation	V_{ld}	$0.65 \text{ mA} \leq I_{REF} \leq 5.5 \text{ mA}$		5	10	mV
Average Temperature Coefficient	$\Delta V_{REG}/\Delta T$	$0.65 \text{ mA} \leq I_{REF} \leq 5.5 \text{ mA}$		75		ppm/°C
Output						
Saturation Voltage	V_{OL}	$I_{OUT} = 4 \text{ mA}$; $T_J > T_{OT}$		200	400	mV
Breakdown Voltage	BV	$I_{OUT} = 100 \mu\text{A}$; $T_J < T_{OT}$	18	30		V
Leakage Current	I_{OH}	$V_{OUT} = 18 \text{ V}$; $T_J < T_{OT}$		1	1000	nA
Over-Temp Sensing						
Temperature Accuracy	$T_{OT(1)}$	$0.7 \text{ mA} \leq I_{REF} \leq 1.3 \text{ mA}$	-3		+3	°C
	$T_{OT(2)}$	$1.55 \text{ mA} \leq I_{REF} \leq 2.6 \text{ mA}$	-3		+3	°C
	$T_{OT(3)}$	$3.0 \text{ mA} \leq I_{REF} \leq 5.0 \text{ mA}$	-3		+3	°C
Hysteresis	H_{OT}	Percentage Error in Nominal Hysteresis	-30		+30	%

Test Circuit

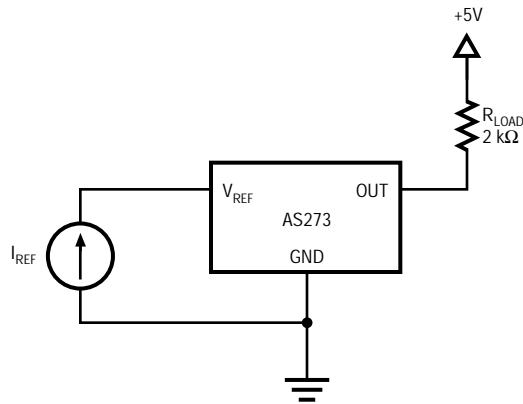

Figure 1. Test Circuit for Output Hysteresis Curve

Typical Performance Curves

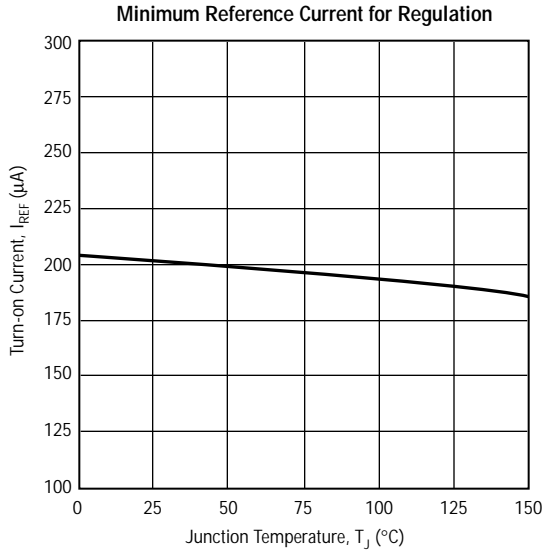

Figure 2

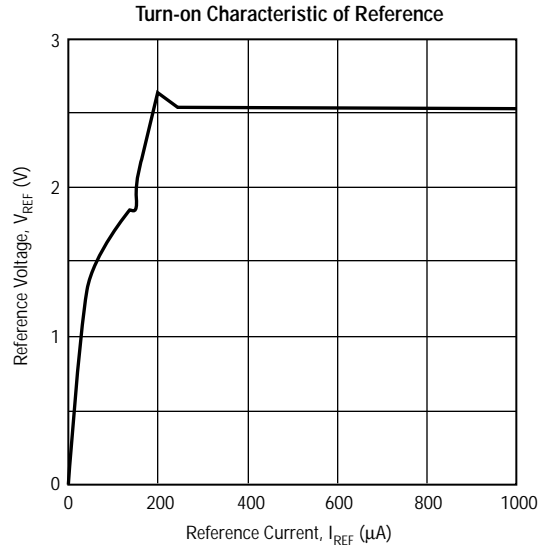

Figure 3

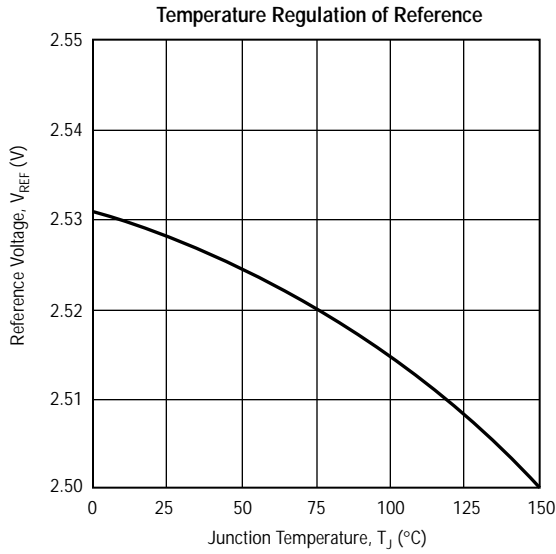

Figure 4

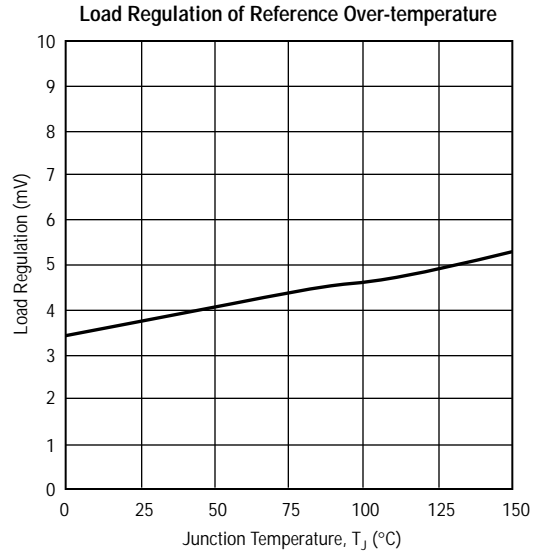

Figure 5

Typical Performance Curves

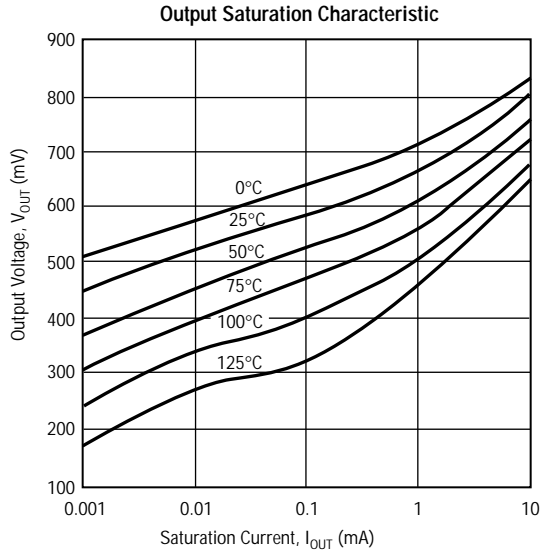

Figure 6

Typical Over-temperature Threshold Distribution – Option G

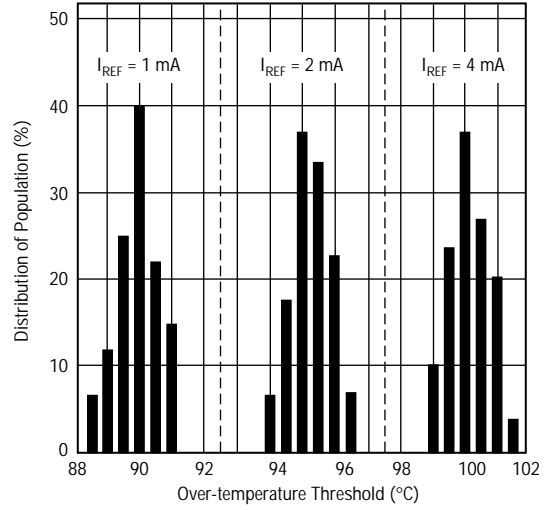

Figure 7

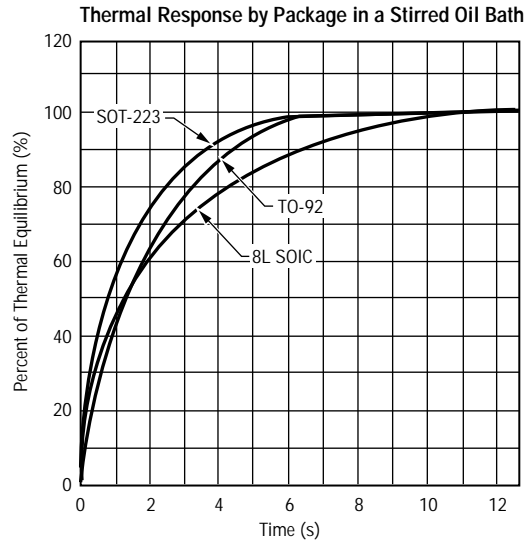

Figure 8

Theory of Operation

The AS273 is an over-temperature detector that gives an over-temp signal when the device junction temperature exceeds a programmed over-temp threshold. Over-temp threshold programming is accomplished by controlling the magnitude of the reference shunt current.

Over-temperature Condition

Internal to the AS273 is a temperature sensor which creates a voltage proportional to the absolute temperature (PTAT) of the die. This PTAT voltage is compared with a fraction of the

reference voltage corresponding to the over-temperature threshold. When the PTAT voltage exceeds the reference voltage, the comparator is tripped and an over-temp signal is given to the output. The output consists of an open collector transistor that pulls low on an over-temp condition. Built into the comparator is temperature hysteresis, which keeps the over-temp signal until the junction temperature has fallen 5°C (or 10°C) below the over-temp threshold. Figure 9 shows the output of the AS273 (with 10°C of hysteresis) over a range of junction temperature.

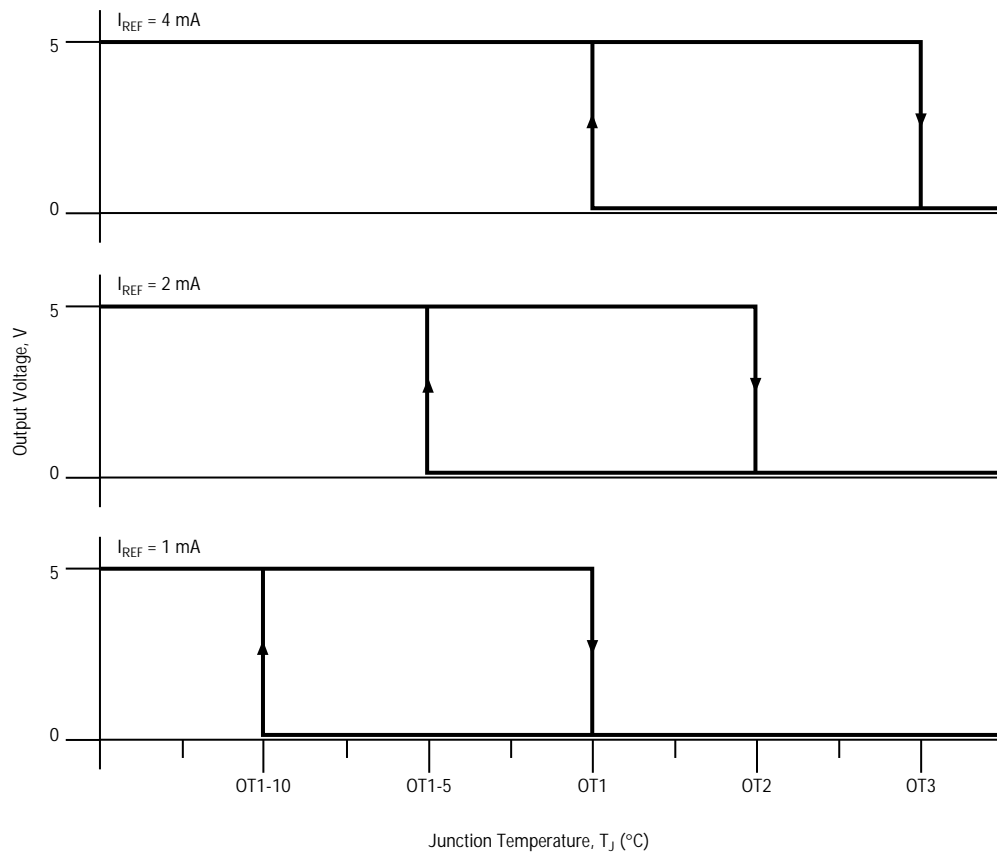

Figure 9. Temperature Characteristic of Output with 10°C of Hysteresis

Current Programming

There are three different over-temp thresholds for each AS273. The detector senses the amount of current being shunted through the 2.5 V reference of pin 1 and programs an over-temp thresh-

old based on the magnitude of that current. Figure 10 illustrates the ranges of reference shunt current, I_{REF} , associated with each of the three over-temp thresholds, OT1, OT2 and OT3.

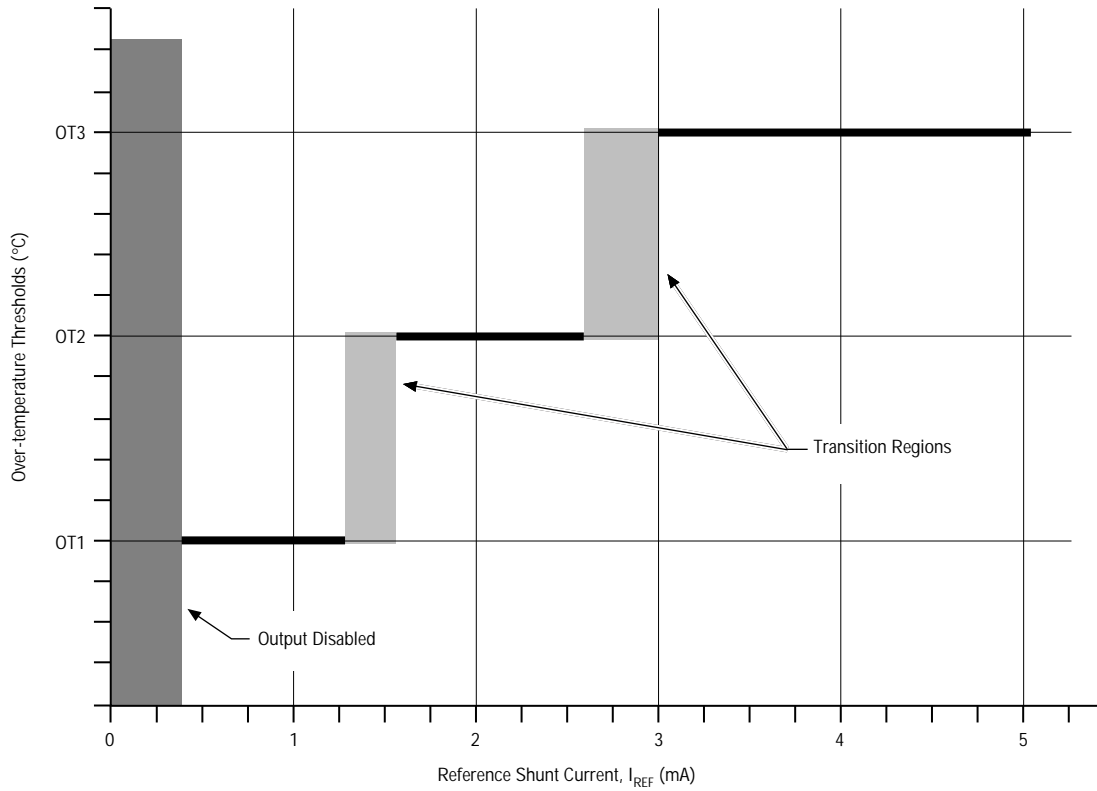

Figure 10. Reference Shunt Current Programming Ranges of Over-temperature Thresholds

Typical Detector Applications

Over-Temperature Detector

The AS273 senses the ambient temperature and turns on its open collector output to indicate an over-temp condition. Each AS273 can be programmed to any one of its three over-temp thresholds by forcing a different range of current into the reference pin.

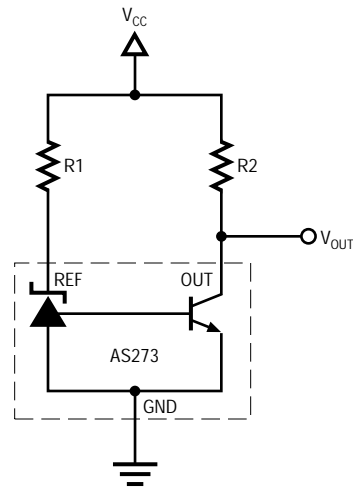

Figure 11.

Dual Speed Fan Control

The diagram of Figure 12 shows an easy way to implement smart fan control. When the temperature is below the over-temp trip point set by R1, the detector's open collector output is off. Therefore, the fan speed is controlled by the ratio between R2 and R3. When the temperature exceeds the over-temp set point, the open collector is turned on, and fan motor runs at its full speed.

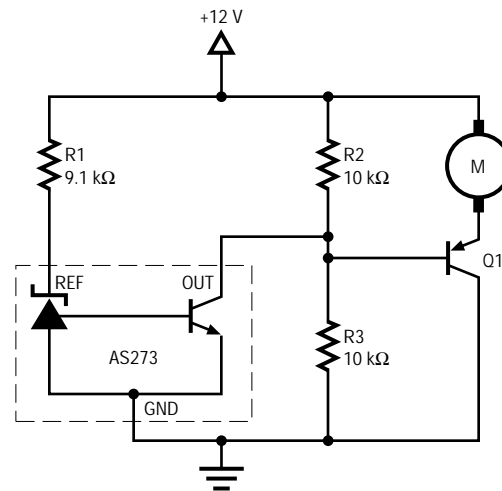

Figure 12.

Over-Temperature Protection with Latch (Low Current)

The diagram of Figure 13 illustrates how a power supply can be shut down with a simple two-transistor latch. When the programmed over-temp is reached, the open collector output of the AS273 enables the latch and pulls V_{CC} below the under-voltage threshold of the AS3842, shutting off the AS3842. The latch can be disabled only with a power reset.

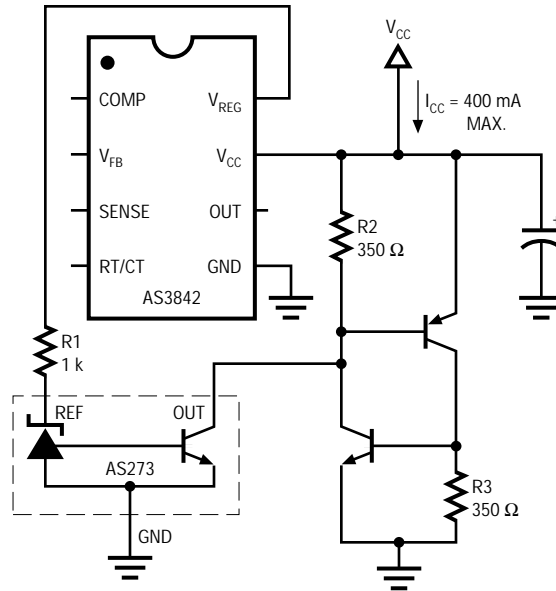

Figure 13.

Over-Temperature Protection with Hysteresis

In this over-temperature circuit, the hysteresis of the AS273 is used to automatically restart the power supply after the temperature drops below the hysteresis temperature window. R1 supplies the current to power the AS273 after the AS3842 and the power supply are shut down. R2 and the external zener set the over-temperature trip point.

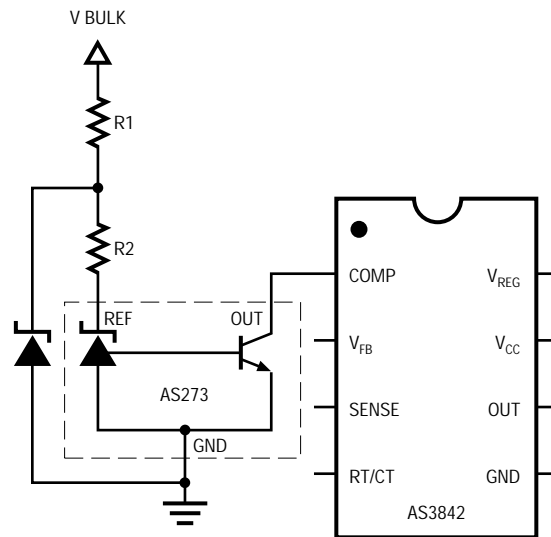

Figure 14.

Adjustable Hysteresis Temperature Detector

The hysteresis of the AS273 can be increased by reprogramming the device to a lower temperature set point upon over-temp. A higher temperature is set by R1. When the temperature exceeds the high-temp set point, the open collector output is turned on and allows R2 to rob current from the reference pin and resets the AS273 to the low-temp set point. As a result, the hysteresis escalates by the difference between the high-temp and the low-temp set points.

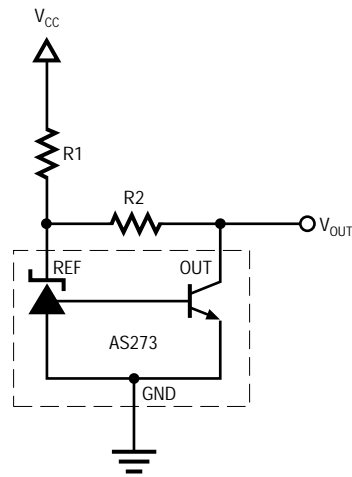
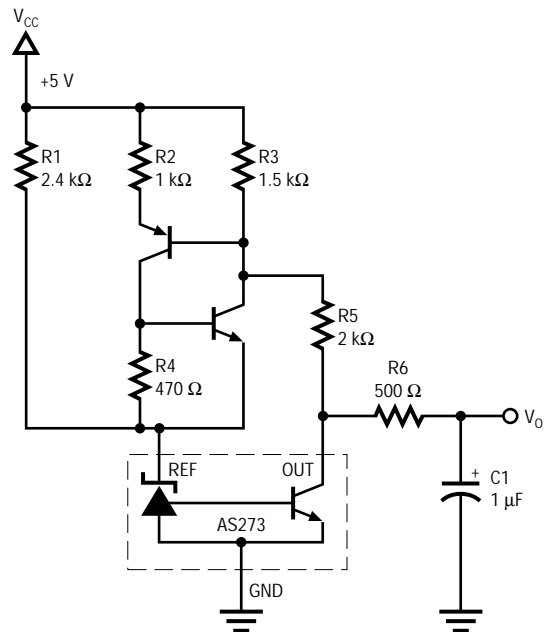

Figure 15.

Three-State Temperature Sensor

In the Three-State Temperature Sensor shown in Figure 16, a low-temp trip point is selected by R1 and a high-temp trip point is selected by the two-transistor latch. When the temperature is below the low-temp set point, V_{OUT} is in the high state ($V_{OUT} = 5.0\text{ V}$). When the temperature exceeds the low-temp set point, the two-transistor latch is set and V_{OUT} is pulled low ($V_{OUT} = 2.5\text{ V}$). The latch also supplies extra current to the reference pin to reset the IC to sense a higher temperature. Once the high-temp is reached, the output will turn “on” ($V_{OUT} = 0.2\text{ V}$). This circuit is highly useful in applications where a stand-by, a warning and a shut-down state are required.



Stand-by State:	$T < T1, T2$	$V_O = 5.0\text{ V}$
Warning State:	$T1 < T < T2$	$V_O = 2.5\text{ V}$
Shut-down State:	$T1, T2 < T$	$V_O = 0.2\text{ V}$

Figure 16.

Notes



LittleDiode supplies new, hard to find or obsolete electronic components and semiconductors all over the world.

With over two million different components listed you are sure to find the part you need.

Feel free to visit us today at our online store:

LittleDiode.com

Looking forward to providing you with the best possible service.