

## Features

- Low Voltage and Standard Voltage Operation
  - 2.7 ( $V_{CC} = 2.7V$  to 5.5V)
  - 1.8 ( $V_{CC} = 1.8V$  to 5.5V)
- Internally Organized 2048 x 8 (16K)
- 2-Wire Serial Interface
- Schmitt Trigger, Filtered Inputs for Noise Suppression
- Bidirectional Data Transfer Protocol
- 100 kHz (1.8V, 2.5V, 2.7V) and 400 kHz (5V) Compatibility
- Write Protect Pin for Hardware Data Protection
- Cascadable Feature Allows for Extended Densities
- 16-Byte Page Write Mode
- Partial Page Writes Are Allowed
- Self-Timed Write Cycle (10 ms max)
- High Reliability
  - Endurance: 1 Million Write Cycles
  - Data Retention: 100 Years
- Automotive Grade, Extended Temperature and Lead-free/Halogen-free Devices Available
- 8-lead PDIP and 8-lead JEDEC SOIC Packages

## Description

The AT24C164 provides 16,384 bits of serial electrically erasable and programmable read only memory (EEPROM) organized as 2048 words of 8 bits each. The device's cascadable feature allows up to eight devices to share a common 2-wire bus. The device is optimized for use in many industrial and commercial applications where low power and low voltage operation are essential. The AT24C164 is available in space saving 8-lead PDIP and 8-lead JEDEC SOIC packages and is accessed via a 2-wire serial interface. In addition, this device is available in 2.7V (2.7V to 5.5V) and 1.8V (1.8V to 5.5V) versions.

## Pin Configurations

| Pin Name | Function           |
|----------|--------------------|
| A0 - A2  | Address Inputs     |
| SDA      | Serial Data        |
| SCL      | Serial Clock Input |
| WP       | Write Protect      |

8-lead PDIP

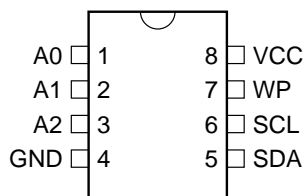

8-lead SOIC

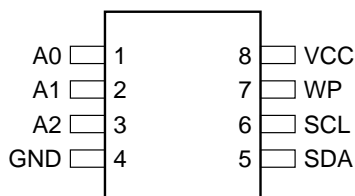

## 2-Wire Serial EEPROM

16K (2048 x 8)

AT24C164



## Absolute Maximum Ratings\*

|   |                   |
|---|-------------------|
| Operating Temperature.....                        | -55° C to +125° C |
| Storage Temperature.....                          | -65° C to +150° C |
| Voltage on Any Pin<br>with Respect to Ground..... | -1.0V to +7.0V    |
| Maximum Operating Voltage.....                    | 6.25V             |
| DC Output Current.....                            | 5.0 mA            |

\*NOTICE: Stresses beyond those listed under “Absolute Maximum Ratings” may cause permanent damage to the device. This is a stress rating only and functional operation of the device at these or any other conditions beyond those indicated in the operational sections of this specification is not implied. Exposure to absolute maximum rating conditions for extended periods may affect device reliability.

## Block Diagram

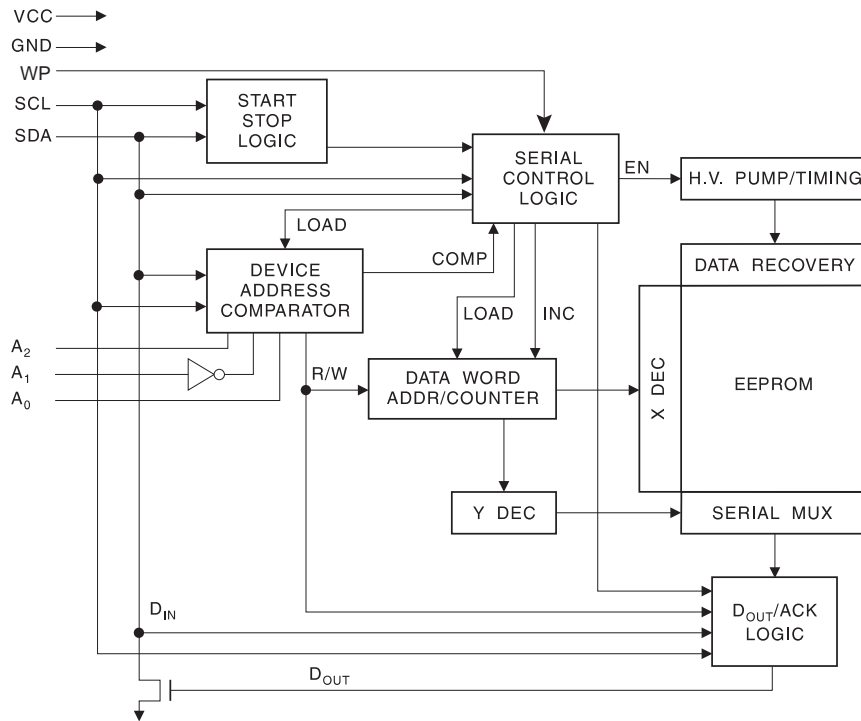

## Pin Description

**SERIAL CLOCK (SCL):** The SCL input is used to positive edge clock data into each EEPROM device and negative edge clock data out of each device.

**SERIAL DATA (SDA):** The SDA pin is bidirectional for serial data transfer. This pin is open-drain driven and may be wire-ORed with any number of other open-drain or open collector devices.

**DEVICE SELECT (A2, A1, A0):** The A2, A1 and A0 pins are device address inputs that may be hardwired or actively driven to  $V_{DD}$  or  $V_{SS}$ . These inputs allow the selection for one of eight possible devices sharing a common bus. The AT24C164 can be made compatible with the AT24C16 by tying A2, A1 and A0 to  $V_{SS}$ . Device addressing is discussed in detail in the device addressing section.

**WRITE PROTECT (WP):** The write protect input, when tied low to GND, allows normal write operations. When WP is tied to  $V_{CC}$ , all write operations are inhibited.

## Memory Organization

The AT24C164 is internally organized with 256 pages of 8 bytes each. Random word addressing requires an 11 bit data word address.

## Pin Capacitance<sup>(1)</sup>

Applicable over recommended operating range from  $T_A = 25^\circ\text{C}$ ,  $f = 1.0\text{ MHz}$ ,  $V_{CC} = +1.8\text{V}$ .

| Symbol    | Test Condition                                    | Max | Units | Conditions            |
|-----------|---|-----|-------|-----------------------|
| $C_{I/O}$ | Input/Output Capacitance (SDA)                    | 8   | pF    | $V_{I/O} = 0\text{V}$ |
| $C_{IN}$  | Input Capacitance ( $A_0, A_1, A_2, \text{SCL}$ ) | 6   | pF    | $V_{IN} = 0\text{V}$  |

Note: 1. This parameter is characterized and is not 100% tested.

## DC Characteristics

Applicable over recommended operating range from:  $T_{AI} = -40^\circ\text{C}$  to  $+85^\circ\text{C}$ ,  $V_{CC} = +1.8\text{V}$  to  $+5.5\text{V}$ ,  $T_{AC} = 0^\circ\text{C}$  to  $+70^\circ\text{C}$ ,  $V_{CC} = +1.8\text{V}$  to  $+5.5\text{V}$  (unless otherwise noted).

| Symbol    | Parameter                               | Test Condition                 | Min                 | Typ  | Max                 | Units         |
|-----------|---|--------------------------------|---------------------|------|---------------------|---------------|
| $V_{CC1}$ | Supply Voltage                          |                                | 1.8                 |      | 5.5                 | V             |
| $V_{CC2}$ | Supply Voltage                          |                                | 2.5                 |      | 5.5                 | V             |
| $V_{CC3}$ | Supply Voltage                          |                                | 2.7                 |      | 5.5                 | V             |
| $V_{CC4}$ | Supply Voltage                          |                                | 4.5                 |      | 5.5                 | V             |
| $I_{CC}$  | Standby Current $V_{CC} = 5.0\text{V}$  | READ at 100 kHz                |                     | 0.4  | 1.0                 | mA            |
| $I_{CC}$  | Standby Current $V_{CC} = 5.0\text{V}$  | WRITE at 100 kHz               |                     | 2.0  | 3.0                 | mA            |
| $I_{SB1}$ | Standby Current $V_{CC} = 1.8\text{V}$  | $V_{IN} = V_{CC}$ or $V_{SS}$  |                     | 0.6  | 3.0                 | $\mu\text{A}$ |
| $I_{SB2}$ | Standby Current $V_{CC} = 2.5\text{V}$  | $V_{IN} = V_{CC}$ or $V_{SS}$  |                     | 1.4  | 4.0                 | $\mu\text{A}$ |
| $I_{SB3}$ | Standby Current $V_{CC} = 2.7\text{V}$  | $V_{IN} = V_{CC}$ or $V_{SS}$  |                     | 1.6  | 4.0                 | $\mu\text{A}$ |
| $I_{SB4}$ | Standby Current $V_{CC} = 5.0\text{V}$  | $V_{IN} = V_{CC}$ or $V_{SS}$  |                     | 8.0  | 18.0                | $\mu\text{A}$ |
| $I_{LI}$  | Input Leakage Current                   | $V_{IN} = V_{CC}$ or $V_{SS}$  |                     | 0.10 | 3.0                 | $\mu\text{A}$ |
| $I_{LO}$  | Output Leakage Current                  | $V_{OUT} = V_{CC}$ or $V_{SS}$ |                     | 0.05 | 3.0                 | $\mu\text{A}$ |
| $V_{IL}$  | Input Low Level <sup>(1)</sup>          |                                | -0.6                |      | $V_{CC} \times 0.3$ | V             |
| $V_{IH}$  | Input High Level <sup>(1)</sup>         |                                | $V_{CC} \times 0.7$ |      | $V_{CC} + 0.5$      | V             |
| $V_{OL2}$ | Output Low Level $V_{CC} = 3.0\text{V}$ | $I_{OL} = 2.1\text{ mA}$       |                     |      | 0.4                 | V             |
| $V_{OL1}$ | Output Low Level $V_{CC} = 1.8\text{V}$ | $I_{OL} = 0.15\text{ mA}$      |                     |      | 0.2                 | V             |

Note: 1.  $V_{IL}$  min and  $V_{IH}$  max are reference only and are not tested.

## AC Characteristics

Applicable over recommended operating range from  $T_A = -40^\circ\text{C}$  to  $+85^\circ\text{C}$ ,  $V_{CC} = +1.8\text{V}$  to  $+5.5\text{V}$ ,  $CL = 1$  TTL Gate and  $100\text{ pF}$  (unless otherwise noted).

| Symbol                   | Parameter  | 2.7-, 2.5-, 1.8-volt |     | 5.0-volt |     | Units         |
|--------------------------|--|----------------------|-----|----------|-----|---------------|
|                          |  | Min                  | Max | Min      | Max |               |
| $f_{SCL}$                | Clock Frequency, SCL   |                      | 100 |          | 400 | kHz           |
| $t_{LOW}$                | Clock Pulse Width Low  | 4.7                  |     | 1.2      |     | $\mu\text{s}$ |
| $t_{HIGH}$               | Clock Pulse Width High   | 4.0                  |     | 0.6      |     | $\mu\text{s}$ |
| $t_I$                    | Noise Suppression Time <sup>(1)</sup>  |                      | 100 |          | 50  | ns            |
| $t_{AA}$                 | Clock Low to Data Out Valid  | 0.1                  | 4.5 | 0.1      | 0.9 | $\mu\text{s}$ |
| $t_{BUF}$                | Time the bus must be free before a new transmission can start <sup>(1)</sup> | 4.7                  |     | 1.2      |     | $\mu\text{s}$ |
| $t_{HD,STA}$             | Start Hold Time  | 4.0                  |     | 0.6      |     | $\mu\text{s}$ |
| $t_{SU,STA}$             | Start Set-up Time  | 4.7                  |     | 0.6      |     | $\mu\text{s}$ |
| $t_{HD,DAT}$             | Data In Hold Time  | 0                    |     | 0        |     | $\mu\text{s}$ |
| $t_{SU,DAT}$             | Data In Set-up Time  | 200                  |     | 100      |     | ns            |
| $t_R$                    | Inputs Rise Time <sup>(1)</sup>  |                      | 1.0 |          | 0.3 | $\mu\text{s}$ |
| $t_F$                    | Inputs Fall Time <sup>(1)</sup>  |                      | 300 |          | 300 | ns            |
| $t_{SU,STO}$             | Stop Set-up Time   | 4.7                  |     | 0.6      |     | $\mu\text{s}$ |
| $t_{DH}$                 | Data Out Hold Time   | 100                  |     | 50       |     | ns            |
| $t_{WR}$                 | Write Cycle Time   |                      | 10  |          | 10  | ms            |
| Endurance <sup>(1)</sup> | 5.0V, 25° C, Page Mode   | 1M                   |     | 1M       |     | Write cycles  |

Note: 1. This parameter is characterized and is not 100% tested.

## Device Operation

**CLOCK and DATA TRANSITIONS:** The SDA pin is normally pulled high with an external device. Data on the SDA pin may change only during SCL low time periods (refer to Data Validity timing diagram). Data changes during SCL high periods will indicate a start or stop condition as defined below.

**START CONDITION:** A high-to-low transition of SDA with SCL high is a start condition which must precede any other command (refer to Start and Stop Definition timing diagram).

**STOP CONDITION:** A low-to-high transition of SDA with SCL high is a stop condition. After a read sequence, the stop command will place the EEPROM in a standby power mode (refer to Start and Stop Definition timing diagram).

**ACKNOWLEDGE:** All addresses and data words are serially transmitted to and from the EEPROM in 8-bit words. The EEPROM sends a zero to acknowledge that it has received each word. This happens during the ninth clock cycle.

**STANDBY MODE:** The AT24C164 features a low power standby mode which is enabled: a) upon power-up and b) after the receipt of the STOP bit and the completion of any internal operations.

**MEMORY RESET:** After an interruption in protocol, power loss or system reset, the AT24C164 can be reset by following these steps:

- (a) Clock up to 9 cycles, (b) look for SDA high in each cycle while SCL is high and then
- (c) create a start condition as SDA is high.

### Bus Timing

SCL: Serial Clock, SDA: Serial Data I/O

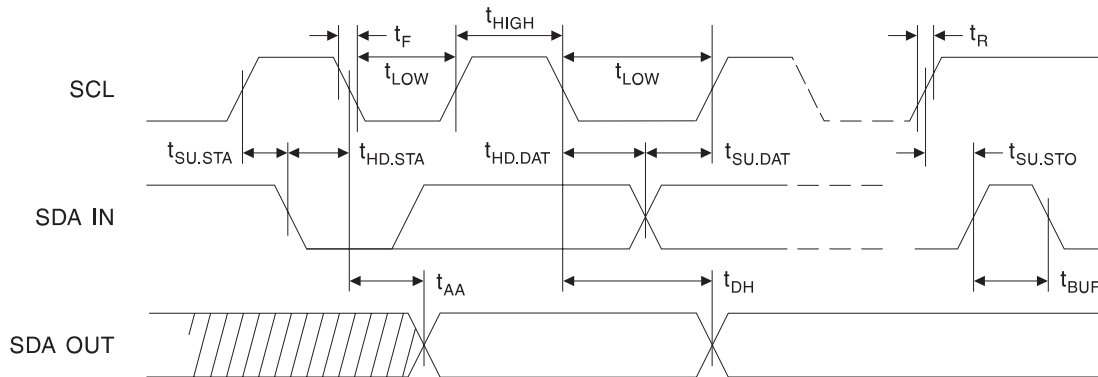

### Write Cycle Timing

SCL: Serial Clock, SDA: Serial Data I/O

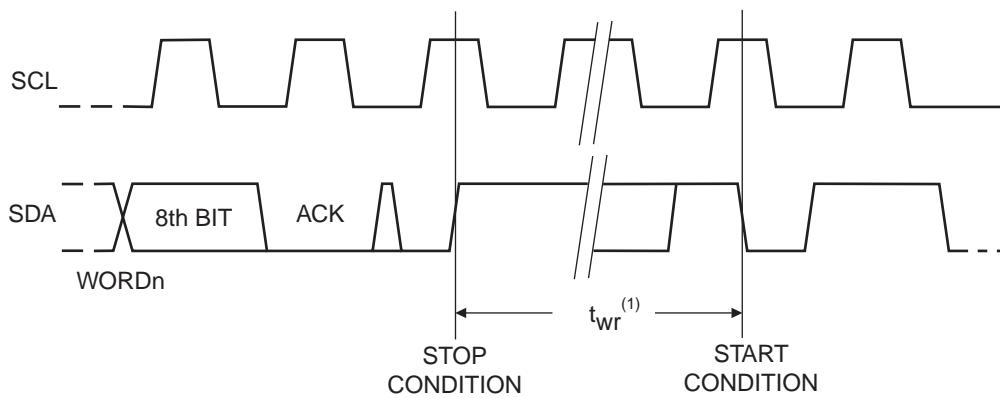

Note: 1. The write cycle time  $t_{wr}$  is the time from a valid stop condition of a write sequence to the end of the internal clear/write cycle.

## Data Validity

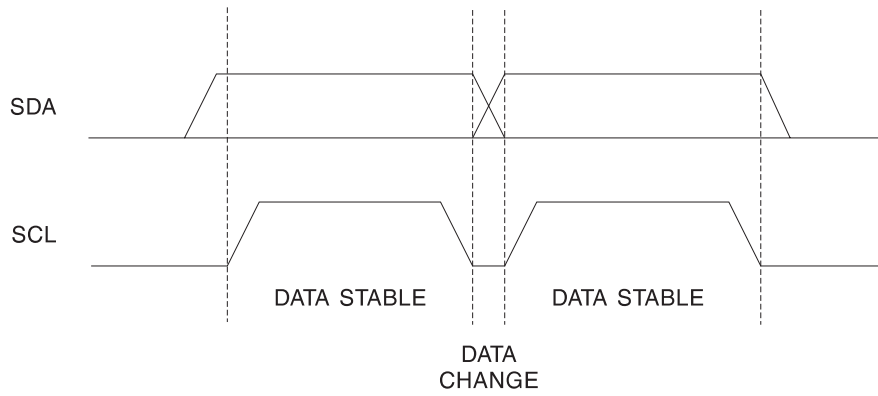

## Start and Stop Definition

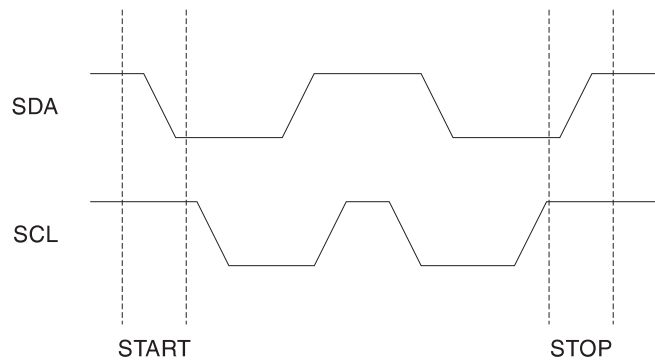

## Output Acknowledge

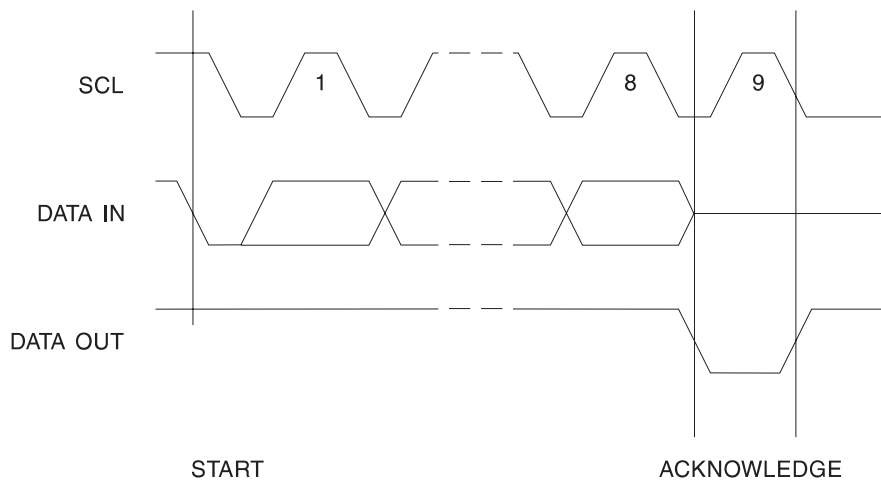

## Device Addressing

The AT24C164 requires an 8-bit device address word following a start condition to enable the chip for read or write operations (refer to Figure 1). The most significant bit must be a one followed by the A2, A1 and A0 device select bits (the A1 bit must be the compliment of the A1 input pin signal). The next 3 bits are used for memory block addressing and select one of the eight 256 x 8 memory blocks. These bits should be considered the three most significant bits of the data word address. The eighth bit of the device address is the read/write select bit. A read operation is selected if this bit is high or a write operation is selected if this bit is low.

Upon a compare of the device address, the EEPROM will output a zero. If a compare is not made, the chip will return to a standby state.

## Write Operations

**BYTE WRITE:** A write operation requires an 8-bit data word address following the device address word and acknowledgment. Upon receipt of this address, the EEPROM will again respond with a zero and then clock in the first 8-bit data word. Following receipt of the 8-bit data word, the EEPROM will output a zero and the addressing device, such as a microcontroller, must terminate the write sequence with a stop condition. At this time the EEPROM enters an internally-timed write cycle,  $t_{WR}$ , to the nonvolatile memory. All inputs are disabled during this write cycle and the EEPROM will not respond until the write is complete (refer to Figure 2).

**PAGE WRITE:** The AT24C164 is capable of a 16-byte page write. A page write is initiated the same as a byte write, but the microcontroller does not send a stop condition after the first data word is clocked in. Instead, after the EEPROM acknowledges receipt of the first data word, the microcontroller can transmit up to fifteen more data words. The EEPROM will respond with a zero after each data word received. The microcontroller must terminate the page write sequence with a stop condition (refer to Figure 3).

The data word address lower 4 bits are internally incremented following the receipt of each data word. The higher data word address bits are not incremented retaining the memory page row location. When the word address, internally generated, reaches the page boundary, the following byte is placed at the beginning of the same page. If more than sixteen data words are transmitted to the EEPROM, the data word address will “roll over” and previous data will be overwritten.

**ACKNOWLEDGE POLLING:** Once the internally-timed write cycle has started and the EEPROM inputs are disabled, acknowledge polling can be initiated. This involves sending a start condition followed by the device address word. The read/write bit is representative of the operation desired. Only if the internal write cycle has completed will the EEPROM respond with a zero allowing the read or write sequence to continue.

## Read Operations

Read operations are initiated the same way as write operations with the exception that the read/write select bit in the device address word is set to one. There are three read operations: current address read, random address read and sequential read.

**CURRENT ADDRESS READ:** The internal data word address counter maintains the last address accessed during the last read or write operation, incremented by one. This address stays valid between operations as long as the chip power is maintained. The address “roll over” during read is from the last byte of the last memory page to the first byte of the first page. The address “roll over” during write is from the last byte of the current page to first byte of the same page.

Once the device address with the read/write select bit set to one is clocked in and acknowledged by the EEPROM, the current address data word is serially clocked out. The microcontroller does not respond with an input zero but does generate a following stop condition (refer to Figure 4).

**RANDOM READ:** A random read requires a “dummy” byte write sequence to load in the data word address. Once the device address word and data word address are clocked in and acknowledged by the EEPROM, the microcontroller must generate another start condition. The microcontroller now initiates a current address read by sending a device address with the read/write select bit high. The EEPROM acknowledges the device address and serially clocks out the data word. The microcontroller does not respond with a zero but does generate a following stop condition (refer to Figure 5).

**SEQUENTIAL READ:** Sequential reads are initiated by either a current address read or a random address read. After the microcontroller receives a data word, it responds with an acknowledge. As long as the EEPROM receives an acknowledge, it will continue to increment the data word address and serially clock out sequential data words. When the memory address limit is reached, the data word address will “roll over” and the sequential read will continue. The sequential read operation is terminated when the microcontroller does not respond with a zero but does generate a following stop condition (refer to Figure 6).

Figure 1. Device Address

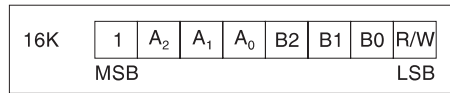

Figure 2. Byte Write

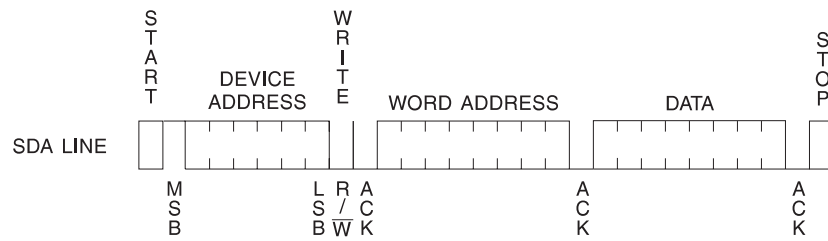
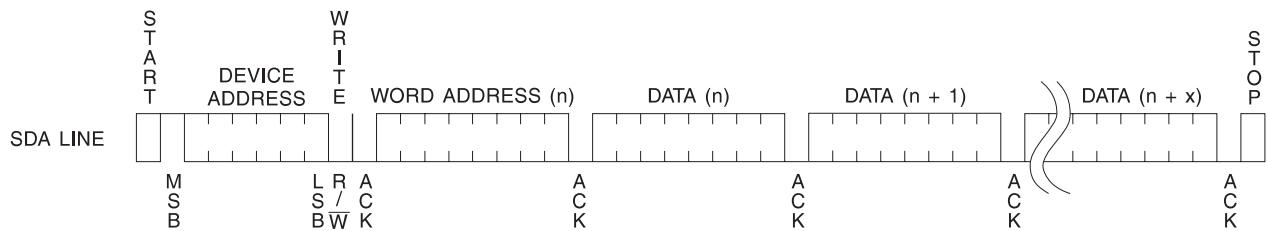
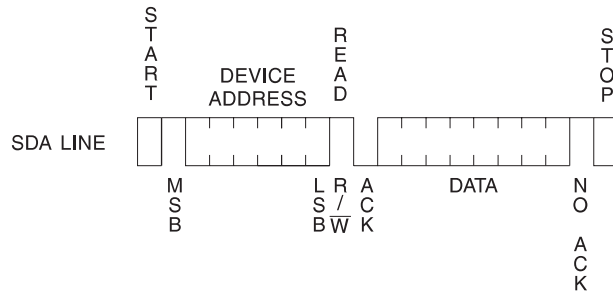

Figure 3. Page Write



**Figure 4. Current Address Read**



**Figure 5. Random Read**

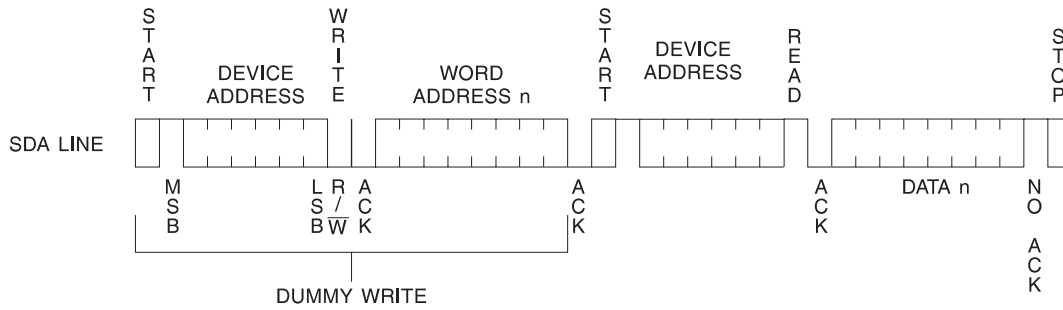

**Figure 6. Sequential Read**

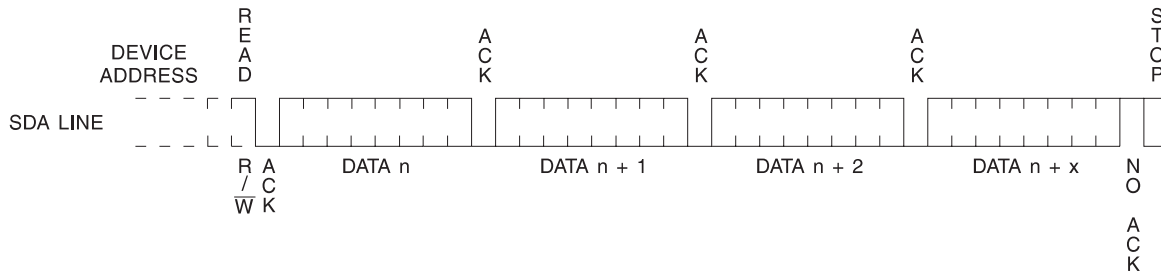

**Ordering Information**

| Ordering Code                          | Package    | Operation Range   |
|--|------------|---|
| AT24C164-10PI-2.7<br>AT24C164-10SI-2.7 | 8P3<br>8S1 | Industrial Temperature<br>(-40° C to 85° C)                           |
| AT24C164-10PI-1.8<br>AT24C164-10SI-1.8 | 8P3<br>8S1 | Industrial Temperature<br>(-40° C to 85° C)                           |
| AT24C164-10SU-2.7<br>AT24C164-10SU-1.8 | 8S1<br>8S1 | Lead-free/Halogen-free<br>Industrial Temperature<br>(-40° C to 85° C) |

Note: For 2.7V devices used in the 4.5V to 5.5V range, please refer to performance values in the AC and DC Characteristics tables.

| Package Type |   |
|--------------|---|
| <b>8P3</b>   | 8-lead, 0.300" Wide, Plastic Dual Inline Package (PDIP)                   |
| <b>8S1</b>   | 8-lead, 0.150" Wide, Plastic Gull Wing Small Outline Package (JEDEC SOIC) |
| Options      |   |
| <b>-2.7</b>  | Low-Voltage (2.7V to 5.5V)  |
| <b>-1.8</b>  | Low-Voltage (1.8V to 5.5V)  |

# Packaging Information

## 8P3 – PDIP

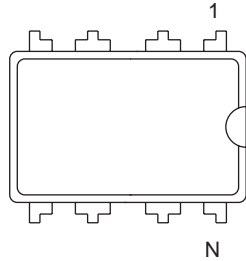

Top View

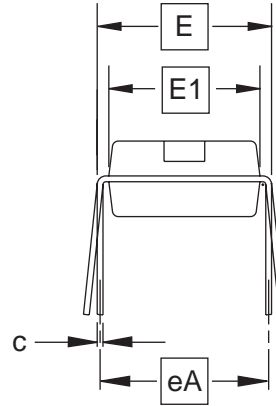

End View

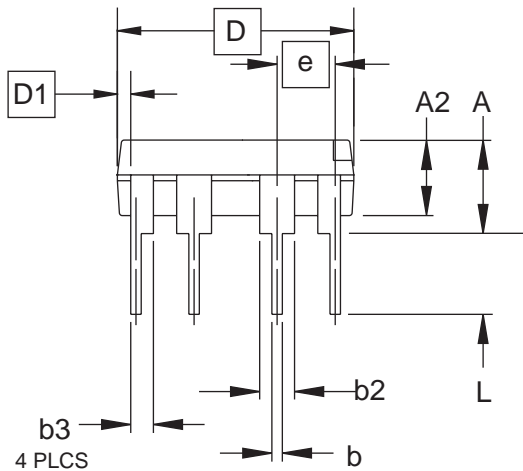

Side View

**COMMON DIMENSIONS**  
(Unit of Measure = inches)

| SYMBOL | MIN       | NOM   | MAX   | NOTE |
|--------|-----------|-------|-------|------|
| A      |           |       | 0.210 | 2    |
| A2     | 0.115     | 0.130 | 0.195 |      |
| b      | 0.014     | 0.018 | 0.022 | 5    |
| b2     | 0.045     | 0.060 | 0.070 | 6    |
| b3     | 0.030     | 0.039 | 0.045 | 6    |
| c      | 0.008     | 0.010 | 0.014 |      |
| D      | 0.355     | 0.365 | 0.400 | 3    |
| D1     | 0.005     |       |       | 3    |
| E      | 0.300     | 0.310 | 0.325 | 4    |
| E1     | 0.240     | 0.250 | 0.280 | 3    |
| e      | 0.100 BSC |       |       |      |
| eA     | 0.300 BSC |       |       | 4    |
| L      | 0.115     | 0.130 | 0.150 | 2    |

- Notes:
1. This drawing is for general information only; refer to JEDEC Drawing MS-001, Variation BA for additional information.
  2. Dimensions A and L are measured with the package seated in JEDEC seating plane Gauge GS-3.
  3. D, D1 and E1 dimensions do not include mold Flash or protrusions. Mold Flash or protrusions shall not exceed 0.010 inch.
  4. E and eA measured with the leads constrained to be perpendicular to datum.
  5. Pointed or rounded lead tips are preferred to ease insertion.
  6. b2 and b3 maximum dimensions do not include Dambar protrusions. Dambar protrusions shall not exceed 0.010 (0.25 mm).

01/09/02



2325 Orchard Parkway  
San Jose, CA 95131

**TITLE**

**8P3**, 8-lead, 0.300" Wide Body, Plastic Dual  
In-line Package (PDIP)

**DRAWING NO.**

8P3

**REV.**

B

8S1 – JEDEC SOIC

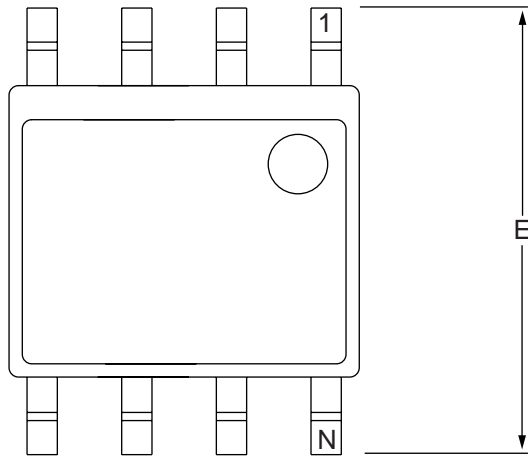

Top View

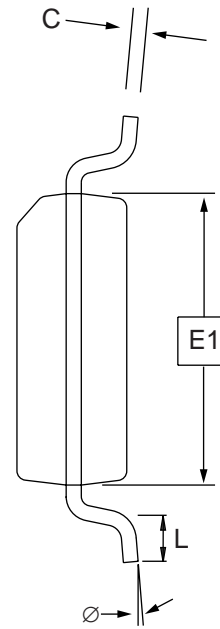

End View

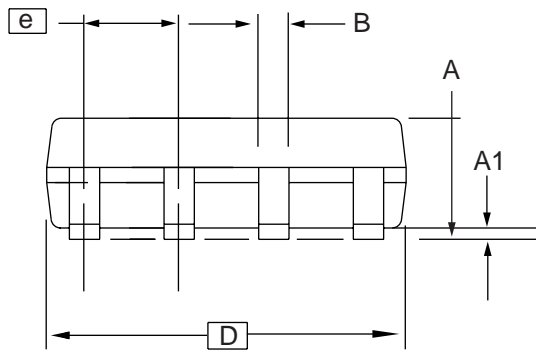

Side View

COMMON DIMENSIONS  
(Unit of Measure = mm)

| SYMBOL        | MIN      | NOM | MAX  | NOTE |
|---------------|----------|-----|------|------|
| A             | 1.35     | –   | 1.75 |      |
| A1            | 0.10     | –   | 0.25 |      |
| b             | 0.31     | –   | 0.51 |      |
| C             | 0.17     | –   | 0.25 |      |
| D             | 4.80     | –   | 5.00 |      |
| E1            | 3.81     | –   | 3.99 |      |
| E             | 5.79     | –   | 6.20 |      |
| e             | 1.27 BSC |     |      |      |
| L             | 0.40     | –   | 1.27 |      |
| $\varnothing$ | 0°       | –   | 8°   |      |

Note: These drawings are for general information only. Refer to JEDEC Drawing MS-012, Variation AA for proper dimensions, tolerances, datums, etc.

10/7/03



1150 E. Cheyenne Mtn. Blvd.  
Colorado Springs, CO 80906

**TITLE**  
8S1, 8-lead (0.150" Wide Body), Plastic Gull Wing  
Small Outline (JEDEC SOIC)

**DRAWING NO.**  
8S1

**REV.**  
B





## Atmel Corporation

2325 Orchard Parkway  
San Jose, CA 95131, USA  
Tel: 1(408) 441-0311  
Fax: 1(408) 487-2600

## Regional Headquarters

### Europe

Atmel Sarl  
Route des Arsenalux 41  
Case Postale 80  
CH-1705 Fribourg  
Switzerland  
Tel: (41) 26-426-5555  
Fax: (41) 26-426-5500

### Asia

Room 1219  
Chinachem Golden Plaza  
77 Mody Road Tsimshatsui  
East Kowloon  
Hong Kong  
Tel: (852) 2721-9778  
Fax: (852) 2722-1369

### Japan

9F, Tonetsu Shinkawa Bldg.  
1-24-8 Shinkawa  
Chuo-ku, Tokyo 104-0033  
Japan  
Tel: (81) 3-3523-3551  
Fax: (81) 3-3523-7581

## Atmel Operations

### Memory

2325 Orchard Parkway  
San Jose, CA 95131, USA  
Tel: 1(408) 441-0311  
Fax: 1(408) 436-4314

### Microcontrollers

2325 Orchard Parkway  
San Jose, CA 95131, USA  
Tel: 1(408) 441-0311  
Fax: 1(408) 436-4314

La Chantrerie  
BP 70602  
44306 Nantes Cedex 3, France  
Tel: (33) 2-40-18-18-18  
Fax: (33) 2-40-18-19-60

### ASIC/ASSP/Smart Cards

Zone Industrielle  
13106 Rousset Cedex, France  
Tel: (33) 4-42-53-60-00  
Fax: (33) 4-42-53-60-01

1150 East Cheyenne Mtn. Blvd.  
Colorado Springs, CO 80906, USA  
Tel: 1(719) 576-3300  
Fax: 1(719) 540-1759

Scottish Enterprise Technology Park  
Maxwell Building  
East Kilbride G75 0QR, Scotland  
Tel: (44) 1355-803-000  
Fax: (44) 1355-242-743

### RF/Automotive

Theresienstrasse 2  
Postfach 3535  
74025 Heilbronn, Germany  
Tel: (49) 71-31-67-0  
Fax: (49) 71-31-67-2340

1150 East Cheyenne Mtn. Blvd.  
Colorado Springs, CO 80906, USA  
Tel: 1(719) 576-3300  
Fax: 1(719) 540-1759

### Biometrics/Imaging/Hi-Rel MPU/ High Speed Converters/RF Datacom

Avenue de Rochepleine  
BP 123  
38521 Saint-Egreve Cedex, France  
Tel: (33) 4-76-58-30-00  
Fax: (33) 4-76-58-34-80

---

## Literature Requests

[www.atmel.com/literature](http://www.atmel.com/literature)

**Disclaimer:** Atmel Corporation makes no warranty for the use of its products, other than those expressly contained in the Company's standard warranty which is detailed in Atmel's Terms and Conditions located on the Company's web site. The Company assumes no responsibility for any errors which may appear in this document, reserves the right to change devices or specifications detailed herein at any time without notice, and does not make any commitment to update the information contained herein. No licenses to patents or other intellectual property of Atmel are granted by the Company in connection with the sale of Atmel products, expressly or by implication. Atmel's products are not authorized for use as critical components in life support devices or systems.

© Atmel Corporation 2004. All rights reserved. Atmel® and combinations thereof, are the registered trademarks of Atmel Corporation or its subsidiaries. Other terms and product names may be the trademarks of others.



Printed on recycled paper.



LittleDiode supplies new, hard to find or obsolete electronic components and semiconductors all over the world.

With over two million different components listed you are sure to find the part you need.

Feel free to visit us today at our online store:

[LittleDiode.com](http://LittleDiode.com)

Looking forward to providing you with the best possible service.