

## Features

- Serial Peripheral Interface (SPI) Compatible
- Supports SPI Modes 0 (0,0) and 3 (1,1)
- Low Voltage and Standard Voltage Operation
  - 5.0 ( $V_{CC} = 4.5V$  to  $5.5V$ )
  - 2.7 ( $V_{CC} = 2.7V$  to  $5.5V$ )
  - 1.8 ( $V_{CC} = 1.8V$  to  $3.6V$ )
- 2.1 MHz Clock Rate
- 32-Byte Page Mode
- Block Write Protection
  - Protect 1/4, 1/2, or Entire Array
- Write Protect ( $\overline{WP}$ ) Pin and Write Disable Instructions for Both Hardware and Software Data Protection
- Self-Timed Write Cycle (5 ms Typical)
- High Reliability
  - Endurance: 1 Million Write Cycles
  - Data Retention: 100 Years
  - ESD Protection: >4000V
- Automotive Grade and Extended Temperature Devices Available
- 8-Pin PDIP, JEDEC SOIC, and 14-Pin and 20-Pin TSSOP Packages

## Description

The AT25080/160/320/640 provides 8192/16384/32768/65536 bits of serial electrically erasable programmable read only memory (EEPROM) organized as 1024/2048/4096/8192 words of 8 bits each. The device is optimized for use in many industrial and commercial applications where low power and low voltage operation

(continued)

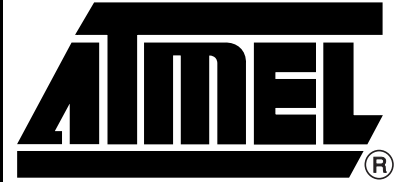

## SPI Serial EEPROMs

8K (1024 x 8)

16K (2048 x 8)

32K (4096 x 8)

64K (8192 x 8)

**AT25080**

**AT25160**

**AT25320**

**AT25640**

## Pin Configuration

Pin Name	Function
$\overline{CS}$	Chip Select
SCK	Serial Data Clock
SI	Serial Data Input
SO	Serial Data Output
GND	Ground
$V_{CC}$	Power Supply
$\overline{WP}$	Write Protect
$\overline{HOLD}$	Suspends Serial Input
NC	No Connect
DC	Don't Connect

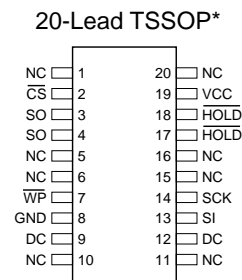
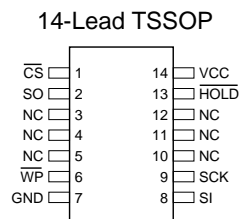
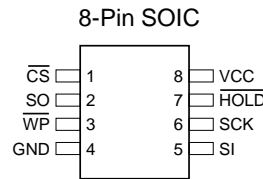
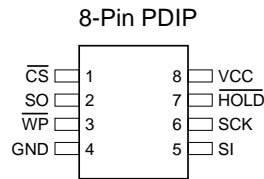

\*Pins 3, 4 and 17, 18 are internally connected for 14-lead TSSOP socket compatibility.



are essential. The AT25080/160/320/640 is available in space saving 8-pin PDIP, JEDEC SOIC, and 14-pin and 20-pin TSSOP packages.

The AT25080/160/320/640 is enabled through the Chip Select pin ( $\overline{CS}$ ) and accessed via a 3-wire interface consisting of Serial Data Input (SI), Serial Data Output (SO), and Serial Clock (SCK). All programming cycles are completely self-timed, and no separate ERASE cycle is required before WRITE.

BLOCK WRITE protection is enabled by programming the status register with one of four blocks of write protection. Separate program enable and program disable instructions are provided for additional data protection. Hardware data protection is provided via the  $\overline{WP}$  pin to protect against inadvertent write attempts to the status register. The  $\overline{HOLD}$  pin may be used to suspend any serial communication without resetting the serial sequence.

### Absolute Maximum Ratings\*

Operating Temperature .....	-55°C to +125°C
Storage Temperature .....	-65°C to +150°C
Voltage on Any Pin with Respect to Ground .....	-1.0V to +7.0V
Maximum Operating Voltage.....	6.25V
DC Output Current.....	5.0 mA

\*NOTICE: Stresses beyond those listed under “Absolute Maximum Ratings” may cause permanent damage to the device. This is a stress rating only and functional operation of the device at these or any other conditions beyond those indicated in the operational sections of this specification is not implied. Exposure to absolute maximum rating conditions for extended periods may affect device reliability.

### Block Diagram

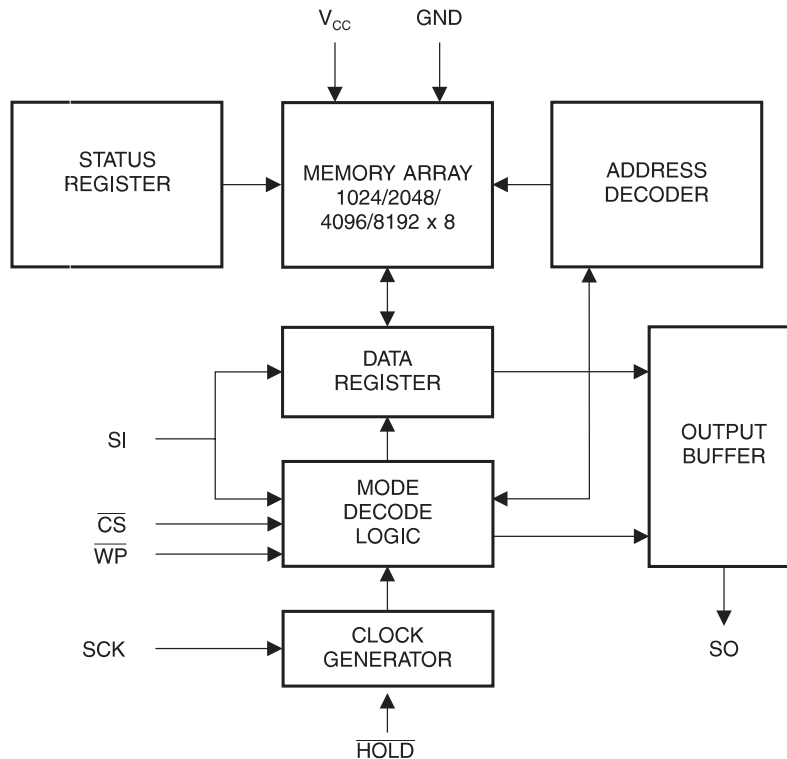

## Pin Capacitance<sup>(1)</sup>

Applicable over recommended operating range from  $T_A = 25^\circ\text{C}$ ,  $f = 1.0\text{ MHz}$ ,  $V_{CC} = +5.0\text{V}$  (unless otherwise noted).

	Test Conditions	Max	Units	Conditions
$C_{OUT}$	Output Capacitance (SO)	8	pF	$V_{OUT} = 0\text{V}$
$C_{IN}$	Input Capacitance ( $\overline{CS}$ , SCK, SI, $\overline{WP}$ , $\overline{HOLD}$ )	6	pF	$V_{IN} = 0\text{V}$

Note: 1. This parameter is characterized and is not 100% tested.

## DC Characteristics

Applicable over recommended operating range from:  $T_{AI} = -40^\circ\text{C}$  to  $+85^\circ\text{C}$ ,  $V_{CC} = +1.8\text{V}$  to  $+5.5\text{V}$ ,  $T_{AC} = 0^\circ\text{C}$  to  $+70^\circ\text{C}$ ,  $V_{CC} = +1.8\text{V}$  to  $+5.5\text{V}$  (unless otherwise noted).

Symbol	Parameter	Test Condition	Min	Typ	Max	Units
$V_{CC1}$	Supply Voltage		1.8		3.6	V
$V_{CC2}$	Supply Voltage		2.7		5.5	V
$V_{CC3}$	Supply Voltage		4.5		5.5	V
$I_{CC1}$	Supply Current	$V_{CC} = 5.0\text{V}$ at 1 MHz, SO = Open			3.0	mA
$I_{CC2}$	Supply Current	$V_{CC} = 5.0\text{V}$ at 2 MHz, SO = Open			5.0	mA
$I_{SB1}$	Standby Current	$V_{CC} = 1.8\text{V}$ , $\overline{CS} = V_{CC}$			0.1	$\mu\text{A}$
$I_{SB2}$	Standby Current	$V_{CC} = 2.7\text{V}$ , $\overline{CS} = V_{CC}$		0.2	0.5	$\mu\text{A}$
$I_{SB3}$	Standby Current	$V_{CC} = 5.0\text{V}$ , $\overline{CS} = V_{CC}$		0.5	2.0	$\mu\text{A}$
$I_{IL}$	Input Leakage	$V_{IN} = 0\text{V}$ to $V_{CC}$	-3.0		3.0	$\mu\text{A}$
$I_{OL}$	Output Leakage	$V_{IN} = 0\text{V}$ to $V_{CC}$ , $T_{AC} = 0^\circ\text{C}$ to $70^\circ\text{C}$	-3.0		3.0	$\mu\text{A}$
$V_{IL}^{(1)}$	Input Low Voltage		-0.6		$V_{CC} \times 0.3$	V
$V_{IH}^{(1)}$	Input High Voltage		$V_{CC} \times 0.7$		$V_{CC} + 0.5$	V
$V_{OL1}$	Output Low Voltage	$4.5\text{V} \leq V_{CC} \leq 5.5\text{V}$		$I_{OL} = 3.0\text{ mA}$	0.4	V
$V_{OH1}$	Output High Voltage			$I_{OH} = -1.6\text{ mA}$	$V_{CC} - 0.8$	V
$V_{OL2}$	Output Low Voltage	$1.8\text{V} \leq V_{CC} \leq 3.6\text{V}$		$I_{OL} = 0.15\text{ mA}$	0.2	V
$V_{OH2}$	Output High Voltage			$I_{OH} = -100\ \mu\text{A}$	$V_{CC} - 0.2$	V

Note: 1.  $V_{IL}$  min and  $V_{IH}$  max are reference only and are not tested.

## AC Characteristics

Applicable over recommended operating range from  $T_A = -40^{\circ}\text{C}$  to  $+85^{\circ}\text{C}$ ,  $V_{CC} = \text{As Specified}$ ,  
 $CL = 1$  TTL Gate and  $100\text{ pF}$  (unless otherwise noted).

Symbol	Parameter	Voltage	Min	Max	Units
$f_{\text{SCK}}$	SCK Clock Frequency	4.5 - 5.5 2.7 - 5.5 1.8 - 3.6	0 0 0	2.1 2.1 0.5	MHz
$t_{\text{RI}}$	Input Rise Time	4.5 - 5.5 2.7 - 5.5 1.8 - 3.6		2 2 2	$\mu\text{s}$
$t_{\text{FI}}$	Input Fall Time	4.5 - 5.5 2.7 - 5.5 1.8 - 3.6		2 2 2	$\mu\text{s}$
$t_{\text{WH}}$	SCK High Time	4.5 - 5.5 2.7 - 5.5 1.8 - 3.6	200 200 800		ns
$t_{\text{WL}}$	SCK Low Time	4.5 - 5.5 2.7 - 5.5 1.8 - 3.6	200 200 800		ns
$t_{\text{CS}}$	$\overline{\text{CS}}$ High Time	4.5 - 5.5 2.7 - 5.5 1.8 - 3.6	250 250 1000		ns
$t_{\text{CSS}}$	$\overline{\text{CS}}$ Setup Time	4.5 - 5.5 2.7 - 5.5 1.8 - 3.6	250 250 1000		ns
$t_{\text{CSH}}$	$\overline{\text{CS}}$ Hold Time	4.5 - 5.5 2.7 - 5.5 1.8 - 3.6	250 250 1000		ns
$t_{\text{SU}}$	Data In Setup Time	4.5 - 5.5 2.7 - 5.5 1.8 - 3.6	50 50 100		ns
$t_{\text{H}}$	Data In Hold Time	4.5 - 5.5 2.7 - 5.5 1.8 - 3.6	50 50 100		ns
$t_{\text{HD}}$	$\overline{\text{Hold}}$ Setup Time	4.5 - 5.5 2.7 - 5.5 1.8 - 3.6	100 100 400		
$t_{\text{CD}}$	$\overline{\text{Hold}}$ Hold Time	4.5 - 5.5 2.7 - 5.5 1.8 - 3.6	200 200 400		ns
$t_{\text{V}}$	Output Valid	4.5 - 5.5 2.7 - 5.5 1.8 - 3.6	0 0 0	200 200 800	ns
$t_{\text{HO}}$	Output Hold Time	4.5 - 5.5 2.7 - 5.5 1.8 - 3.6	0 0 0		ns

**AC Characteristics (Continued)**

Applicable over recommended operating range from  $T_A = -40^{\circ}\text{C}$  to  $+85^{\circ}\text{C}$ ,  $V_{CC} = \text{As Specified}$ ,  $CL = 1$  TTL Gate and  $100\text{ pF}$  (unless otherwise noted).

Symbol	Parameter	Voltage	Min	Max	Units
$t_{LZ}$	Hold to Output Low Z	4.5 - 5.5	0	100	ns
		2.7 - 5.5	0	100	
		1.8 - 3.6	0	100	
$t_{HZ}$	Hold to Output High Z	4.5 - 5.5		100	ns
		2.7 - 5.5		100	
		1.8 - 3.6		100	
$t_{DIS}$	Output Disable Time	4.5 - 5.5		250	ns
		2.7 - 5.5		250	
		1.8 - 3.6		1000	
$t_{WC}$	Write Cycle Time	4.5 - 5.5		5	ms
		2.7 - 5.5		10	
		1.8 - 3.6		20	
Endurance <sup>(1)</sup>	5.0V, 25°C, Page Mode		1M		Write Cycles

Note: 1. This parameter is characterized and is not 100% tested.

## Serial Interface Description

**MASTER:** The device that generates the serial clock.

**SLAVE:** Because the Serial Clock pin (SCK) is always an input, the AT25080/160/320/640 always operates as a slave.

**TRANSMITTER/RECEIVER:** The AT25080/160/320/640 has separate pins designated for data transmission (SO) and reception (SI).

**MSB:** The Most Significant Bit (MSB) is the first bit transmitted and received.

**SERIAL OP-CODE:** After the device is selected with  $\overline{CS}$  going low, the first byte will be received. This byte contains the op-code that defines the operations to be performed.

**INVALID OP-CODE:** If an invalid op-code is received, no data will be shifted into the AT25080/160/320/640, and the serial output pin (SO) will remain in a high impedance state until the falling edge of  $\overline{CS}$  is detected again. This will reinitialize the serial communication.

**CHIP SELECT:** The AT25080/160/320/640 is selected when the  $\overline{CS}$  pin is low. When the device is not selected, data will not be accepted via the SI pin, and the serial output pin (SO) will remain in a high impedance state.

**HOLD:** The  $\overline{HOLD}$  pin is used in conjunction with the  $\overline{CS}$  pin to select the AT25080/160/320/640. When the device is selected and a serial sequence is underway,  $\overline{HOLD}$  can be used to pause the serial communication with the master device without resetting the serial sequence. To pause, the  $\overline{HOLD}$  pin must be brought low while the SCK pin is low. To resume serial communication, the  $\overline{HOLD}$  pin is brought high while the SCK pin is low (SCK may still toggle during  $\overline{HOLD}$ ). Inputs to the SI pin will be ignored while the SO pin is in the high impedance state.

**WRITE PROTECT:** The write protect pin ( $\overline{WP}$ ) will allow normal read/write operations when held high. When the WP pin is brought low and WPEN bit is "1", all write operations

to the status register are inhibited.  $\overline{WP}$  going low while  $\overline{CS}$  is still low will interrupt a write to the status register. If the internal write cycle has already been initiated,  $\overline{WP}$  going low will have no effect on any write operation to the status register. The  $\overline{WP}$  pin function is blocked when the WPEN bit in the status register is "0". This will allow the user to install the AT25080/160/320/640 in a system with the  $\overline{WP}$  pin tied to ground and still be able to write to the status register. All  $\overline{WP}$  pin functions are enabled when the WPEN bit is set to "1".

## SPI Serial Interface

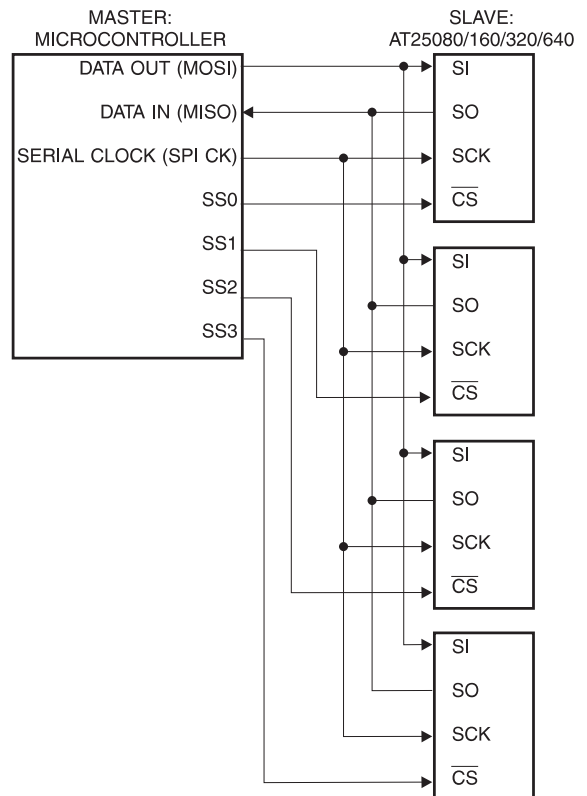

## Functional Description

The AT25080/160/320/640 is designed to interface directly with the synchronous serial peripheral interface (SPI) of the 6805 and 68HC11 series of microcontrollers.

The AT25080/160/320/640 utilizes an 8 bit instruction register. The list of instructions and their operation codes are contained in Table 1. All instructions, addresses, and data are transferred with the MSB first and start with a high-to-low CS transition.

**Table 1.** Instruction Set for the AT25080/160/320/640

Instruction Name	Instruction Format	Operation
WREN	0000 X110	Set Write Enable Latch
WRDI	0000 X100	Reset Write Enable Latch
RDSR	0000 X101	Read Status Register
WRSR	0000 X001	Write Status Register
READ	0000 X011	Read Data from Memory Array
WRITE	0000 X010	Write Data to Memory Array

**WRITE ENABLE (WREN):** The device will power up in the write disable state when  $V_{CC}$  is applied. All programming instructions must therefore be preceded by a Write Enable instruction.

**WRITE DISABLE (WRDI):** To protect the device against inadvertent writes, the Write Disable instruction disables all programming modes. The WRDI instruction is independent of the status of the WP pin.

**READ STATUS REGISTER (RDSR):** The Read Status Register instruction provides access to the status register. The READY/BUSY and Write Enable status of the device can be determined by the RDSR instruction. Similarly, the Block Write Protection bits indicate the extent of protection employed. These bits are set by using the WRSR instruction.

**Table 2.** Status Register Format

Bit 7	Bit 6	Bit 5	Bit 4	Bit 3	Bit 2	Bit 1	Bit 0
WPEN	X	X	X	BP1	BP0	WEN	$\overline{RDY}$

**Table 3.** Read Status Register Bit Definition

Bit	Definition
Bit 0 ( $\overline{RDY}$ )	Bit 0 = 0 ( $\overline{RDY}$ ) indicates the device is READY. Bit 0 = 1 indicates the write cycle is in progress.
Bit 1 (WEN)	Bit 1 = 0 indicates the device is not WRITE ENABLED. Bit 1 = 1 indicates the device is WRITE ENABLED.
Bit 2 (BP0)	See Table 3.
Bit 3 (BP1)	See Table 3.
Bits 4-6 are 0s when device is not in an internal write cycle.	
Bit 7 (WPEN)	See Table 4.
Bits 0-7 are 1s during an internal write cycle.	

**WRITE STATUS REGISTER (WRSR):** The WRSR instruction allows the user to select one of four levels of protection. The AT25080/160/320/640 is divided into four array segments. One quarter (1/4), one half (1/2), or all of the memory segments can be protected. Any of the data within any selected segment will therefore be READ only. The block write protection levels and corresponding status register control bits are shown in Table 4.

The three bits, BP0, BP1, and WPEN are nonvolatile cells that have the same properties and functions as the regular memory cells (e.g. WREN,  $t_{WC}$ , RDSR).

**Table 4.** Block Write Protect Bits

Level	Status Register Bits		Array Addresses Protected			
	BP1	BP0	AT25080	AT25160	AT25320	AT25640
0	0	0	None	None	None	None
1(1/4)	0	1	0300 -03FF	0600 -07FF	0C00 -0FFF	1800 -1FFF
2(1/2)	1	0	0200 -03FF	0400 -07FF	0800 -0FFF	1000 -1FFF
3(All)	1	1	0000 -03FF	0000 -07FF	0000 -0FFF	0000 -1FFF

The WRSR instruction also allows the user to enable or disable the write protect ( $\overline{WP}$ ) pin through the use of the Write Protect Enable (WPEN) bit. Hardware write protection is enabled when the  $\overline{WP}$  pin is low and the WPEN bit is "1". Hardware write protection is disabled when either the  $\overline{WP}$  pin is high or the WPEN bit is "0". When the device is hardware write protected, writes to the Status Register, including the Block Protect bits and the WPEN bit, and the block-protected sections in the memory array are disabled.

Writes are only allowed to sections of the memory which are not block-protected.

**NOTE:** When the WPEN bit is hardware write protected, it cannot be changed back to “0”, as long as the  $\overline{WP}$  pin is held low.

**Table 5.** WPEN Operation

WPEN	$\overline{WP}$	WEN	Protected Blocks	Unprotected Blocks	Status Register
0	X	0	Protected	Protected	Protected
0	X	1	Protected	Writable	Writable
1	Low	0	Protected	Protected	Protected
1	Low	1	Protected	Writable	Protected
X	High	0	Protected	Protected	Protected
X	High	1	Protected	Writable	Writable

**READ SEQUENCE (READ):** Reading the AT25080/160/320/640 via the SO (Serial Output) pin requires the following sequence. After the  $\overline{CS}$  line is pulled low to select a device, the READ op-code is transmitted via the SI line followed by the byte address to be read (A15-A0, Refer to Table 6). Upon completion, any data on the SI line will be ignored. The data (D7-D0) at the specified address is then shifted out onto the SO line. If only one byte is to be read, the  $\overline{CS}$  line should be driven high after the data comes out. The READ sequence can be continued since the byte address is automatically incremented and data will continue to be shifted out. When the highest address is reached, the address counter will roll over to the lowest address allowing the entire memory to be read in one continuous READ cycle.

**WRITE SEQUENCE (WRITE):** In order to program the AT25080/160/320/640, two separate instructions must be executed. First, the device **must be write enabled** via the Write Enable (WREN) Instruction. Then a Write (WRITE) Instruction may be executed. Also, the address of the

memory location(s) to be programmed must be outside the protected address field location selected by the Block Write Protection Level. During an internal write cycle, all commands will be ignored except the RDSR instruction.

A Write Instruction requires the following sequence. After the  $\overline{CS}$  line is pulled low to select the device, the WRITE op-code is transmitted via the SI line followed by the byte address (A15-A0) and the data (D7-D0) to be programmed (Refer to Table 6). Programming will start after the  $\overline{CS}$  pin is brought high. (The LOW to High transition of the  $\overline{CS}$  pin must occur during the SCK low time immediately after clocking in the D0 (LSB) data bit.

The READY/BUSY status of the device can be determined by initiating a READ STATUS REGISTER (RDSR) Instruction. If Bit 0 = 1, the WRITE cycle is still in progress. If Bit 0 = 0, the WRITE cycle has ended. Only the READ STATUS REGISTER instruction is enabled during the WRITE programming cycle.

The AT25080/160/320/640 is capable of a 32-byte PAGE WRITE operation. After each byte of data is received, the five low order address bits are internally incremented by one; the high order bits of the address will remain constant. If more than 32-bytes of data are transmitted, the address counter will roll over and the previously written data will be overwritten. The AT25080/160/320/640 is automatically returned to the write disable state at the completion of a WRITE cycle.

**NOTE:** If the device is not Write enabled (WREN), the device will ignore the Write instruction and will return to the standby state, when  $\overline{CS}$  is brought high. A new  $\overline{CS}$  falling edge is required to re-initiate the serial communication.

**Table 6.** Address Key

Address	AT25080	AT25160	AT25320	AT25640
$A_N$	$A_9 - A_0$	$A_{10} - A_0$	$A_{11} - A_0$	$A_{12} - A_0$
Don't Care Bits	$A_{15} - A_{10}$	$A_{15} - A_{11}$	$A_{15} - A_{12}$	$A_{15} - A_{13}$

## Timing Diagrams

### Synchronous Data Timing (for Mode 0)

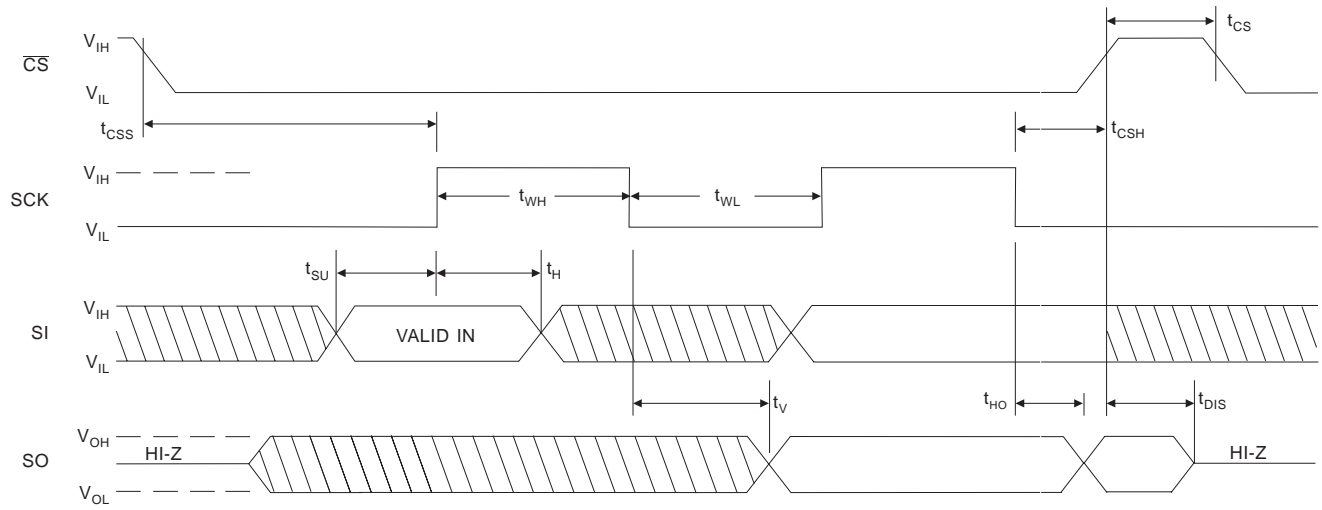

### WREN Timing

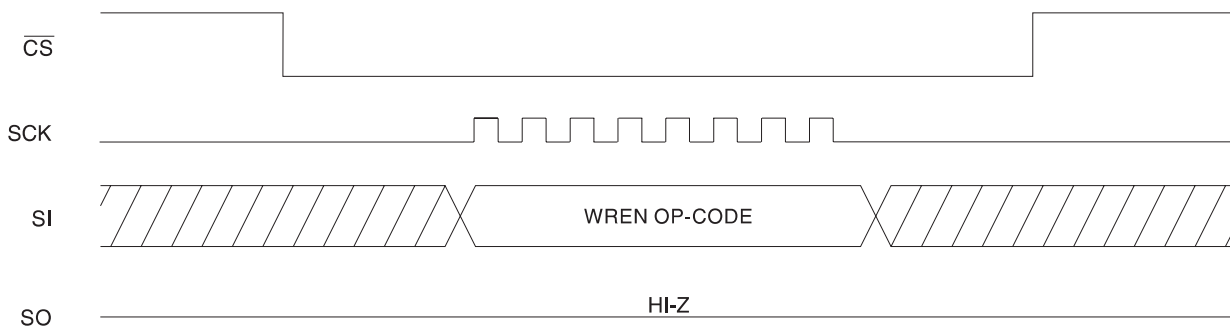

### WRDI Timing

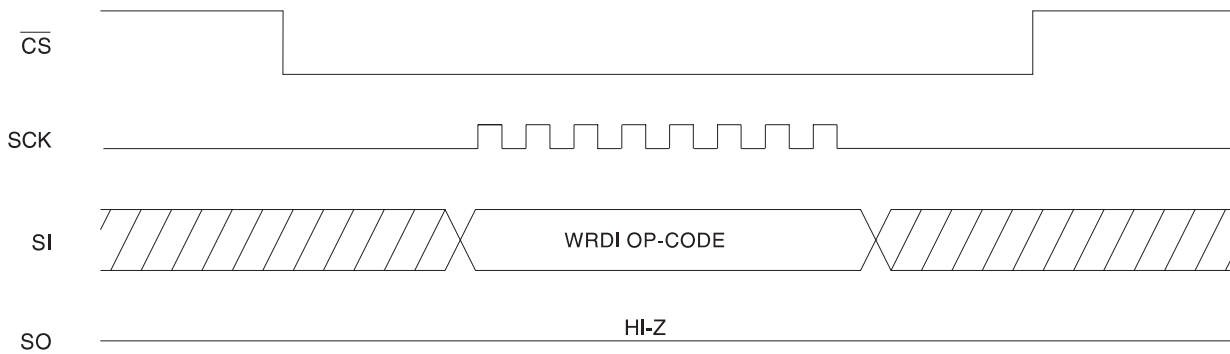

### RDST Timing

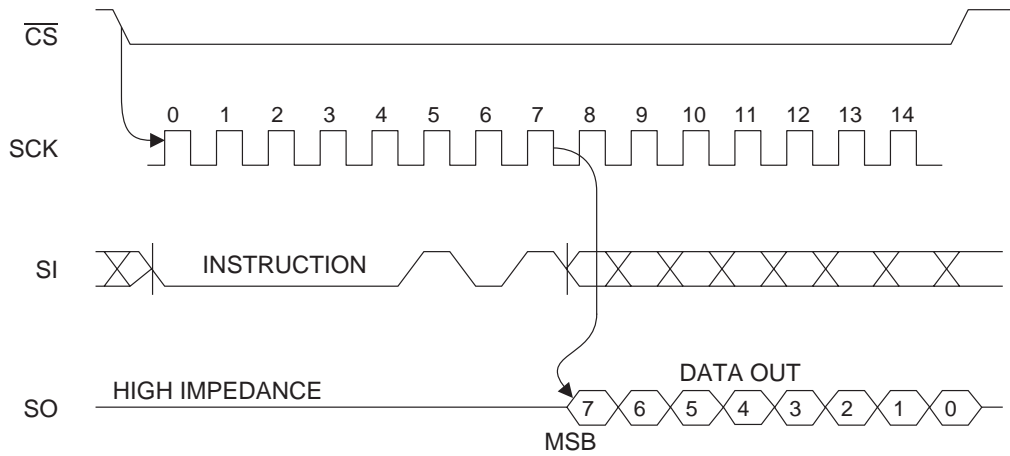

### WRSR Timing

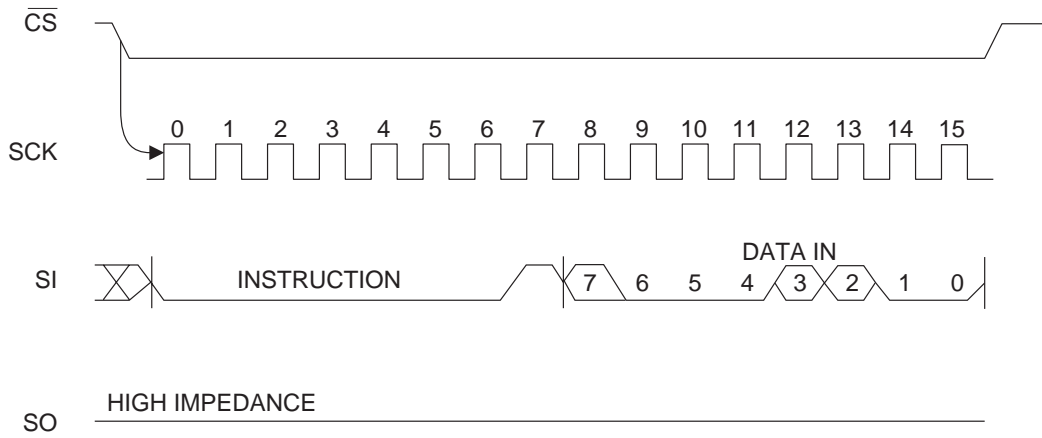

### READ Timing

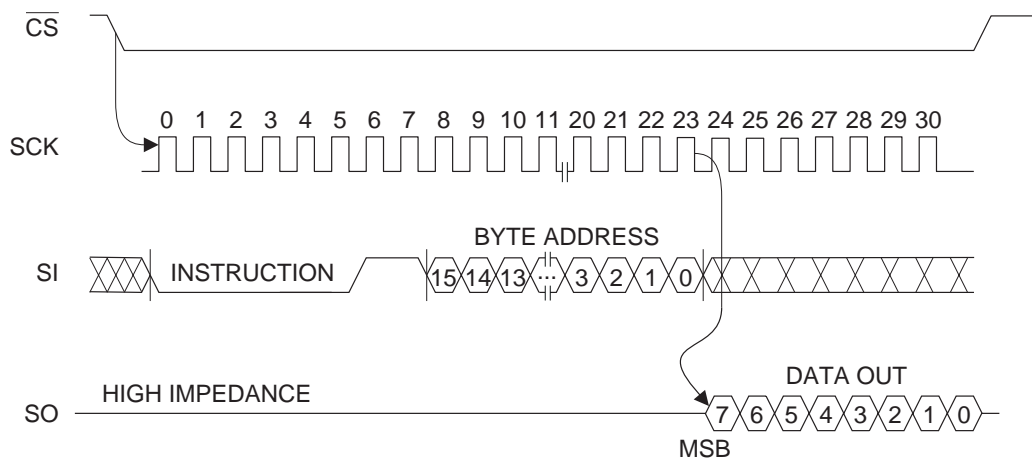

**WRITE Timing**

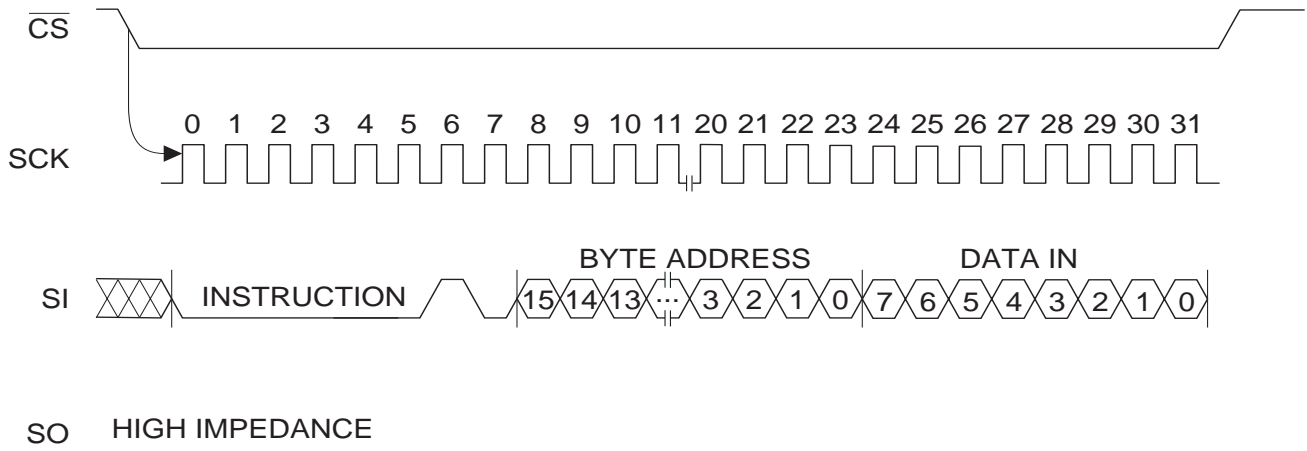

**HOLD Timing**

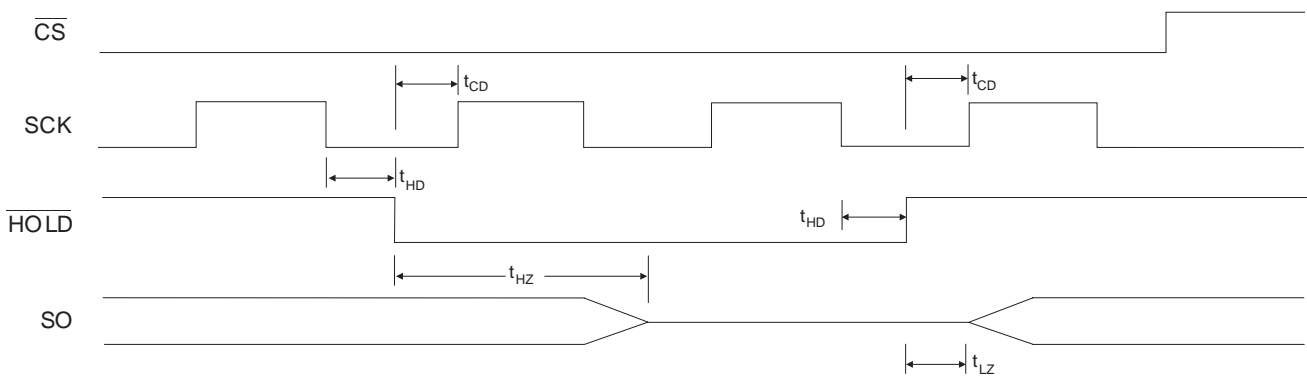



## AT25080 Ordering Information

$t_{WC}$ (max) (ms)	$I_{CC}$ (max) ( $\mu$ A)	$I_{SB}$ (max) ( $\mu$ A)	$f_{MAX}$ (kHz)	Ordering Code	Package	Operation Range
5	5000	2.0	2100	AT25080-10PC AT25080N-10SC AT25080T1-10TC	8P3 8S1 14T	Commercial (0°C to 70°C)
10	3000	0.5	2100	AT25080-10PC-2.7 AT25080N-10SC-2.7 AT25080T1-10TC-2.7	8P3 8S1 14T	Commercial (0°C to 70°C)
20	3000	0.2	500	AT25080-10PC-1.8 AT25080N-10SC-1.8 AT25080T1-10TC-1.8	8P3 8S1 14T	Commercial (0°C to 70°C)
5	5000	2.0	2100	AT25080-10PI AT25080N-10SI AT25080T1-10TI	8P3 8S1 14T	Industrial (-40°C to 85°C)
10	3000	0.5	2100	AT25080-10PI-2.7 AT25080N-10SI-2.7 AT25080T1-10TI-2.7	8P3 8S1 14T	Industrial (-40°C to 85°C)
20	3000	0.2	500	AT25080-10PI-1.8 AT25080N-10SI-1.8 AT25080T1-10TI-1.8	8P3 8S1 14T	Industrial (-40°C to 85°C)

Package Type	
<b>8P3</b>	8-Lead, 0.300" Wide, Plastic Dual Inline Package (PDIP)
<b>8S1</b>	8-Lead, 0.150" Wide, Plastic Gull Wing Small Outline (JEDEC SOIC)
<b>14T</b>	14-Lead, 0.170" Wide, Thin Shrink Small Outline Package (TSSOP)
Options	
<b>Blank</b>	Standard Device (4.5V to 5.5V)
<b>-2.7</b>	Low Voltage (2.7V to 5.5V)
<b>-1.8</b>	Low Voltage (1.8V to 3.6V)

**AT25160 Ordering Information**

$t_{WC}$ (max) (ms)	$I_{CC}$ (max) ( $\mu A$ )	$I_{SB}$ (max) ( $\mu A$ )	$f_{MAX}$ (kHz)	Ordering Code	Package	Operation Range
5	5000	2.0	2100	AT25160-10PC AT25160N-10SC AT25160T1-10TC	8P3 8S1 14T	Commercial (0°C to 70°C)
10	3000	0.5	2100	AT25160-10PC-2.7 AT25160N-10SC-2.7 AT25160T1-10TC-2.7	8P3 8S1 14T	Commercial (0°C to 70°C)
20	3000	0.2	500	AT25160-10PC-1.8 AT25160N-10SC-1.8 AT25160T1-10TC-1.8	8P3 8S1 14T	Commercial (0°C to 70°C)
5	5000	2.0	2100	AT25160-10PI AT25160N-10SI AT25160T1-10TI	8P3 8S1 14T	Industrial (-40°C to 85°C)
10	3000	0.5	2100	AT25160-10PI-2.7 AT25160N-10SI-2.7 AT25160T1-10TI-2.7	8P3 8S1 14T	Industrial (-40°C to 85°C)
20	3000	0.2	500	AT25160-10PI-1.8 AT25160N-10SI-1.8 AT25160T1-10TI-1.8	8P3 8S1 14T	Industrial (-40°C to 85°C)

Package Type	
<b>8P3</b>	8-Lead, 0.300" Wide, Plastic Dual Inline Package (PDIP)
<b>8S1</b>	8-Lead, 0.150" Wide, Plastic Gull Wing Small Outline (JEDEC SOIC)
<b>14T</b>	14-Lead, 0.170" Wide, Thin Shrink Small Outline Package (TSSOP)
Options	
<b>Blank</b>	Standard Device (4.5V to 5.5V)
<b>-2.7</b>	Low Voltage (2.7V to 5.5V)
<b>-1.8</b>	Low Voltage (1.8V to 3.6V)





## AT25320 Ordering Information

$t_{WC}$ (max) (ms)	$I_{CC}$ (max) ( $\mu A$ )	$I_{SB}$ (max) ( $\mu A$ )	$f_{MAX}$ (kHz)	Ordering Code	Package	Operation Range
5	5000	2.0	2100	AT25320-10PC AT25320N-10SC AT25320T1-10TC AT25320T2-10TC	8P3 8S1 14T 20T	Commercial (0°C to 70°C)
10	3000	0.5	2100	AT25320-10PC-2.7 AT25320N-10SC-2.7 AT25320T1-10TC-2.7 AT25320T2-10TC-2.7	8P3 8S1 14T 20T	Commercial (0°C to 70°C)
20	3000	0.2	500	AT25320-10PC-1.8 AT25320N-10SC-1.8 AT25320T1-10TC-1.8 AT25320T2-10TC-1.8	8P3 8S1 14T 20T	Commercial (0°C to 70°C)
5	5000	2.0	2100	AT25320-10PI AT25320N-10SI AT25320T1-10TI AT25320T2-10TI	8P3 8S1 14T 20T	Industrial (-40°C to 85°C)
10	3000	0.5	2100	AT25320-10PI-2.7 AT25320N-10SI-2.7 AT25320T1-10TI-2.7 AT25320T2-10TI-2.7	8P3 8S 14T 20T	Industrial (-40°C to 85°C)
20	3000	0.2	500	AT25320-10PI-1.8 AT25320N-10SI-1.8 AT25320T1-10TI-1.8 AT25320T2-10TI-1.8	8P3 8S1 14T 20T	Industrial (-40°C to 85°C)

Package Type	
<b>8P3</b>	8-Lead, 0.300" Wide, Plastic Dual Inline Package (PDIP)
<b>8S1</b>	8-Lead, 0.150" Wide, Plastic Gull Wing Small Outline (JEDEC SOIC)
<b>14T</b>	14-Lead, 0.170" Wide, Thin Shrink Small Outline Package (TSSOP)
<b>20T</b>	20-Lead, 0.170" Wide, Thin Shrink Small Outline Package (TSSOP)
Options	
<b>Blank</b>	Standard Device (4.5V to 5.5V)
<b>-2.7</b>	Low Voltage (2.7V to 5.5V)
<b>-1.8</b>	Low Voltage (1.8V to 3.6V)

**AT25640 Ordering Information**

<b>t<sub>wc</sub> (max)</b> <b>(ms)</b>	<b>I<sub>cc</sub> (max)</b> <b>(μA)</b>	<b>I<sub>sb</sub> (max)</b> <b>(μA)</b>	<b>f<sub>max</sub></b> <b>(kHz)</b>	<b>Ordering Code</b>	<b>Package</b>	<b>Operation Range</b>
5	5000	2.0	2100	AT25640-10PC AT25640N-10SC AT25640T1-10TC AT25640T2-10TC	8P3 8S1 14T 20T	Commercial (0°C to 70°C)
10	3000	0.5	2100	AT25640-10PC-2.7 AT25640N-10SC-2.7 AT25640T1-10TC-2.7 AT25640T2-10TC-2.7	8P3 8S1 14T 20T	Commercial (0°C to 70°C)
20	3000	0.2	500	AT25640-10PC-1.8 AT25640N-10SC-1.8 AT25640T1-10TC-1.8 AT25640T2-10TC-1.8	8P3 8S1 14T 20T	Commercial (0°C to 70°C)
5	5000	2.0	2100	AT25640-10PI AT25640N-10SI AT25640T1-10TI AT25640T2-10TI	8P3 8S1 14T 20T	Industrial (-40°C to 85°C)
10	3000	0.5	2100	AT25640-10PI-2.7 AT25640N-10SI-2.7 AT25640T1-10TI-2.7 AT25640T2-10TI-2.7	8P3 8S1 14T 20T	Industrial (-40°C to 85°C)
20	3000	0.2	500	AT25640-10PI-1.8 AT25640N-10SI-1.8 AT25640T1-10TI-1.8 AT25640T2-10TI-1.8	8P3 8S1 14T 20T	Industrial (-40°C to 85°C)

<b>Package Type</b>	
<b>8P3</b>	8-Lead, 0.300" Wide, Plastic Dual Inline Package (PDIP)
<b>8S1</b>	8-Lead, 0.150" Wide, Plastic Gull Wing Small Outline (JEDEC SOIC)
<b>14T</b>	14-Lead, 0.170" Wide, Thin Shrink Small Outline Package (TSSOP)
<b>20T</b>	20-Lead, 0.170" Wide, Thin Shrink Small Outline Package (TSSOP)
<b>Options</b>	
<b>Blank</b>	Standard Device (4.5V to 5.5V)
<b>-2.7</b>	Low Voltage (2.7V to 5.5V)
<b>-1.8</b>	Low Voltage (1.8V to 3.6V)



## Packaging Information

**8P3**, 8-Lead, 0.300" Wide,  
Plastic Dual Inline Package (PDIP)  
Dimensions in Inches and (Millimeters)  
JEDEC STANDARD MS-001 BA

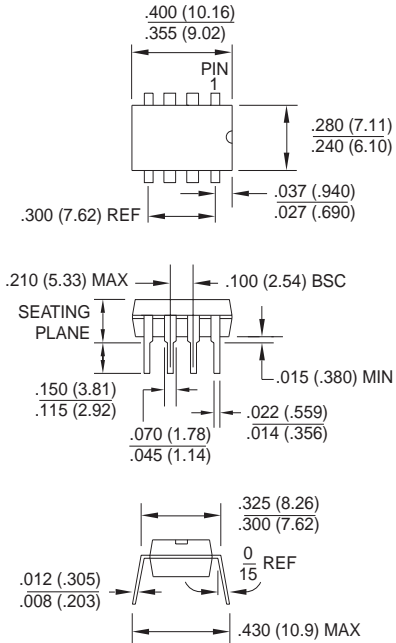

**8S1**, 8-Lead, 0.150" Wide,  
Plastic Gull Wing Small Outline (JEDEC SOIC)  
Dimensions in Inches and (Millimeters)

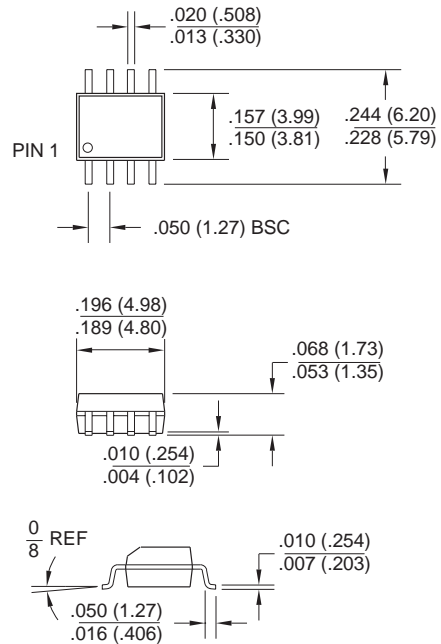

**14T**, 14-Lead, 0.170" Wide,  
Thin Super Small Outline Package (TSSOP)  
Dimensions in Inches and (Millimeters)

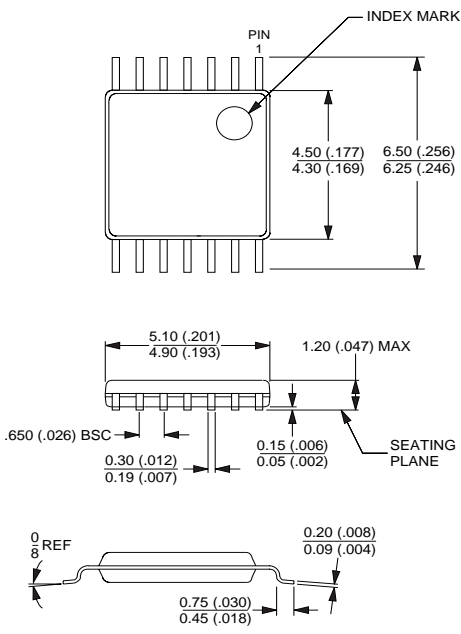

**20T**, 20-Lead, 0.170" Wide,  
Thin Super Small Outline Package (TSSOP)  
Dimensions in Inches and (Millimeters)

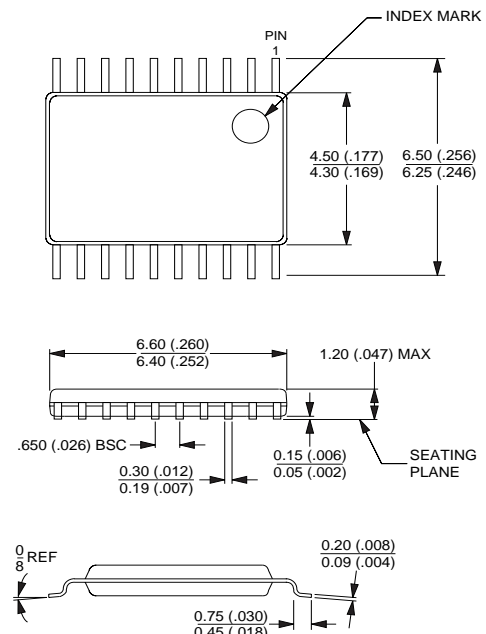

This datasheet has been downloaded from:

[www.DatasheetCatalog.com](http://www.DatasheetCatalog.com)

Datasheets for electronic components.



LittleDiode supplies new, hard to find or obsolete electronic components and semiconductors all over the world.

With over two million different components listed you are sure to find the part you need.

Feel free to visit us today at our online store:

**[LittleDiode.com](http://LittleDiode.com)**

Looking forward to providing you with the best possible service.