

Features

- Fast Read Access Time - 90 ns
- Dual Voltage Range Operation
 - Low Voltage Power Supply Range, 3.0V to 3.6V
 - or Standard 5V \pm 10% Supply Range
- Compatible with JEDEC Standard AT27C020
- Low Power CMOS Operation
 - 20 μ A max. (less than 1 μ A typical) Standby for $V_{CC} = 3.6V$
 - 29 mW max. Active at 5 MHz for $V_{CC} = 3.6V$
- JEDEC Standard Packages
 - 32-Lead PLCC
 - 32-Lead TSOP (8 X 20 mm)
 - 32-Lead VSOP (8 x 14 mm)
- High Reliability CMOS Technology
 - 2,000V ESD Protection
 - 200 mA Latchup Immunity
- Rapid™ Programming Algorithm - 100 μ s/byte (typical)
- Two-Line Control
- CMOS and TTL Compatible Inputs and Outputs
 - JEDEC Standard for LVTTTL
- Integrated Product Identification Code
- Commercial and Industrial Temperature Ranges

Description

The AT27LV020A is a high performance, low power, low voltage 2,097,152 bit one-time programmable read only memory (OTP EPROM) organized as 256K by 8 bits. It requires only one supply in the range of 3.0 to 3.6V in normal read mode operation, making it ideal for fast, portable systems using battery power.

Pin Configurations

Pin Name	Function
A0 - A17	Addresses
O0 - O7	Outputs
\overline{CE}	Chip Enable
\overline{OE}	Output Enable
\overline{PGM}	Program Strobe

PLCC, Top View

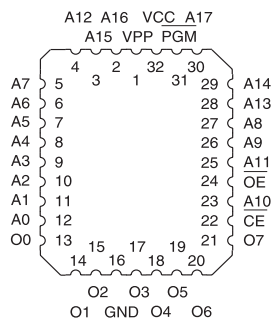

TSOP, VSOP Top View

Type 1

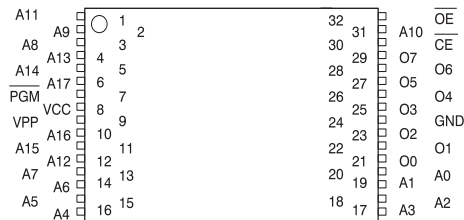

**2 Megabit
(256K x 8)
Low Voltage
OTP EPROM**

AT27LV020A





Atmel's innovative design techniques provide fast speeds that rival 5V parts while keeping the low power consumption of a 3V supply. At $V_{CC} = 3.0V$, any byte can be accessed in less than 90 ns. With a typical power dissipation of only 18 mW at 5 MHz and $V_{CC} = 3.3V$, the AT27LV020A consumes less than one fifth the power of a standard 5V EPROM. Standby mode supply current is typically less than 1 μA at 3.3V.

The AT27LV020A is available in industry standard JEDEC approved one-time programmable (OTP) plastic PLCC, TSOP and VSOP packages. All devices feature two-line control (\overline{CE} , \overline{OE}) to give designers the flexibility to prevent bus contention.

The AT27LV020A operating with V_{CC} at 3.0V produces TTL level outputs that are compatible with standard TTL logic devices operating at $V_{CC} = 5.0V$. The device is also capable of standard 5-volt operation making it ideally suited for dual supply range systems or card products that are pluggable in both 3-volt and 5-volt hosts.

Atmel's AT27LV020A has additional features to ensure high quality and efficient production use. The Rapid™ Programming Algorithm reduces the time required to program the part and guarantees reliable programming. Programming time is typically only 100 μs /byte. The Integrated Product Identification Code electronically identifies the device and manufacturer. This feature is used by industry standard programming equipment to select the proper programming algorithms and voltages. The AT27LV020A programs exactly the same way as a standard 5V AT27C020 and uses the same programming equipment.

System Considerations

Switching between active and standby conditions via the Chip Enable pin may produce transient voltage excursions. Unless accommodated by the system design, these transients may exceed data sheet limits, resulting in device non-conformance. At a minimum, a 0.1 μF high frequency, low inherent inductance, ceramic capacitor should be utilized for each device. This capacitor should be connected between the V_{CC} and Ground terminals of the device, as close to the device as possible. Additionally, to stabilize the supply voltage level on printed circuit boards with large EPROM arrays, a 4.7 μF bulk electrolytic capacitor should be utilized, again connected between the V_{CC} and Ground terminals. This capacitor should be positioned as close as possible to the point where the power supply is connected to the array.

Block Diagram

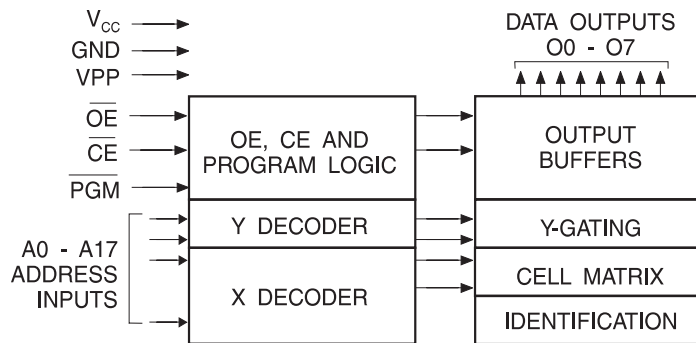

Absolute Maximum Ratings*

Temperature Under Bias	-40°C to +85°C
Storage Temperature	-65°C to +125°C
Voltage on Any Pin with Respect to Ground	-2.0V to +7.0V ⁽¹⁾
Voltage on A9 with Respect to Ground	-2.0V to +14.0V ⁽¹⁾
V _{PP} Supply Voltage with Respect to Ground	-2.0V to +14.0V ⁽¹⁾

*NOTICE: Stresses beyond those listed under “Absolute Maximum Ratings” may cause permanent damage to the device. This is a stress rating only and functional operation of the device at these or any other conditions beyond those indicated in the operational sections of this specification is not implied. Exposure to absolute maximum rating conditions for extended periods may affect device reliability.

Note: 1. Minimum voltage is -0.6V dc which may undershoot to -2.0V for pulses of less than 20 ns. Maximum output pin voltage is V_{CC} + 0.75V dc which may be exceeded if certain precautions are observed (consult application notes) and which may overshoot to +7.0 volts for pulses of less than 20 ns.

Operating Modes

Mode \ Pin	CE	OE	PGM	Ai	V _{PP}	V _{CC}	Outputs
Read ⁽²⁾	V _{IL}	V _{IL}	X ⁽¹⁾	Ai	X	V _{CC} ⁽²⁾	D _{OUT}
Output Disable ⁽²⁾	X	V _{IH}	X	X	X	V _{CC} ⁽²⁾	High Z
Standby ⁽²⁾	V _{IH}	X	X	X	X	V _{CC} ⁽²⁾	High Z
Rapid Program ⁽³⁾	V _{IL}	V _{IH}	V _{IL}	Ai	V _{PP}	V _{CC} ⁽³⁾	D _{IN}
PGM Verify ⁽³⁾	V _{IL}	V _{IL}	V _{IH}	Ai	V _{PP}	V _{CC} ⁽³⁾	D _{OUT}
PGM Inhibit ⁽³⁾	V _{IH}	X	X	X	V _{PP}	V _{CC} ⁽³⁾	High Z
Product Identification ^(3, 5)	V _{IL}	V _{IL}	X	A9 = V _H ⁽⁴⁾ A0 = V _{IH} or V _{IL} A1 - A17 = V _{IL}	X	V _{CC} ⁽³⁾	Identification Code

- Notes:
- X can be V_{IL} or V_{IH}.
 - Read, output disable, and standby modes require, 3.0V ≤ V_{CC} ≤ 3.6V, or 4.5V ≤ V_{CC} ≤ 5.5V.
 - Refer to Programming Characteristics. Programming modes require V_{CC} = 6.5V.
 - V_H = 12.0 ± 0.5V.
 - Two identifier bytes may be selected. All Ai inputs are held low (V_{IL}), except A9 which is set to V_H and A0 which is toggled low (V_{IL}) to select the Manufacturer's Identification byte and high (V_{IH}) to select the Device Code byte.



DC and AC Operating Conditions for Read Operation

		AT27LV020A		
		-90	-12	-15
Operating Temperature (Case)	Com.	0°C - 70°C	0°C - 70°C	0°C - 70°C
	Ind.	-40°C - 85°C	-40°C - 85°C	-40°C - 85°C
V _{CC} Power Supply		3.0V to 3.6V	3.0V to 3.6V	3.0V to 3.6V
		5V ± 10%	5V ± 10%	5V ± 10%

DC and Operating Characteristics for Read Operation

Symbol	Parameter	Condition	Min	Max	Units
V_{CC} = 3.0V to 3.6V					
I _{LI}	Input Load Current	V _{IN} = 0V to V _{CC}		±1	μA
I _{LO}	Output Leakage Current	V _{OUT} = 0V to V _{CC}		±5	μA
I _{PP1} ⁽²⁾	Read/Standby Current	V _{PP} = V _{CC}		10	μA
I _{SB}	V _{CC} ⁽¹⁾ Standby Current	I _{SB1} (CMOS), $\overline{CE} = V_{CC} \pm 0.3V$		20	μA
		I _{SB2} (TTL), $\overline{CE} = 2.0$ to V _{CC} + 0.5V		100	μA
I _{CC}	V _{CC} Active Current	f = 5 MHz, I _{OUT} = 0 mA, $\overline{CE} = V_{IL}$		8	mA
V _{IL}	Input Low Voltage		-0.6	0.8	V
V _{IH}	Input High Voltage		2.0	V _{CC} + 0.5	V
V _{OL}	Output Low Voltage	I _{OL} = 2.0 mA		0.4	V
V _{OH}	Output High Voltage	I _{OH} = -2.0 mA	2.4		V
V_{CC} = 4.5V to 5.5V					
I _{LI}	Input Load Current	V _{IN} = 0V to V _{CC}		±1	μA
I _{LO}	Output Leakage Current	V _{OUT} = 0V to V _{CC}		±5	μA
I _{PP1} ⁽²⁾	Read/Standby Current	V _{PP} = V _{CC}		10	μA
I _{SB}	V _{CC} ⁽¹⁾ Standby Current	I _{SB1} (CMOS), $\overline{CE} = V_{CC} \pm 0.3V$		100	μA
		I _{SB2} (TTL), $\overline{CE} = 2.0$ to V _{CC} + 0.5V		1	mA
I _{CC}	V _{CC} Active Current	f = 5 MHz, I _{OUT} = 0 mA, $\overline{CE} = V_{IL}$		25	mA
V _{IL}	Input Low Voltage		-0.6	0.8	V
V _{IH}	Input High Voltage		2.0	V _{CC} + 0.5	V
V _{OL}	Output Low Voltage	I _{OL} = 2.1 mA		0.4	V
V _{OH}	Output High Voltage	I _{OH} = -400 μA	2.4		V

AC Characteristics for Read Operation ($V_{CC} = 3.0V$ to $3.6V$ and $4.5V$ to $5.5V$)

Symbol	Parameter	Condition	AT27LV020A						Units
			-90		-12		-15		
			Min	Max	Min	Max	Min	Max	
$t_{ACC}^{(3)}$	Address to Output Delay	$\overline{CE} = \overline{OE} = V_{IL}$		90		120		150	ns
$t_{CE}^{(2)}$	\overline{CE} to Output Delay	$\overline{OE} = V_{IL}$		90		120		150	ns
$t_{OE}^{(2,3)}$	\overline{OE} to Output Delay	$\overline{CE} = V_{IL}$		50		50		60	ns
$t_{DF}^{(4,5)}$	\overline{OE} or \overline{CE} High to Output Float, whichever occurred first			40		40		50	ns
t_{OH}	Output Hold from Address, \overline{CE} or \overline{OE} , whichever occurred first		0		0		0		ns

AC Waveforms for Read Operation (1)

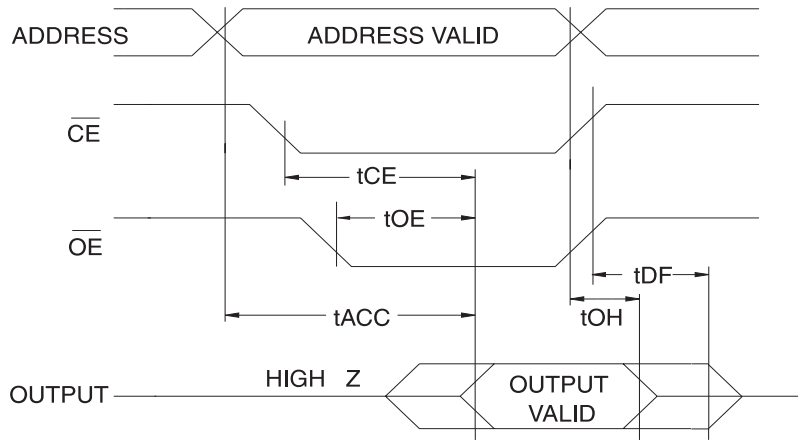

- Notes:
1. Timing measurement references are 0.8V and 2.0V. Input AC drive levels are 0.45V and 2.4V, unless otherwise specified.
 2. \overline{OE} may be delayed up to $t_{CE} - t_{OE}$ after the falling edge of CE without impact on t_{CE} .
 3. \overline{OE} may be delayed up to $t_{ACC} - t_{OE}$ after the address is valid without impact on t_{ACC} .
 4. This parameter is only sampled and is not 100% tested.
 5. Output float is defined as the point when data is no longer driven.

Input Test Waveform and Measurement Level

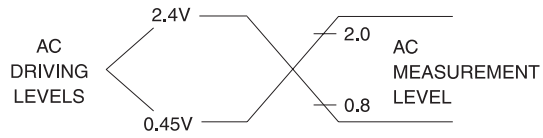

$t_R, t_F < 20 \text{ ns}$ (1% to 90%)

Output Test Load

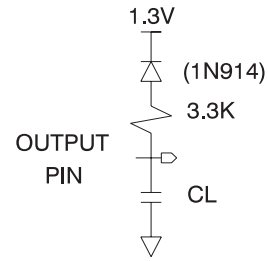

Note: $CL = 1 \text{ pF}$ including jig clearance.

Pin Capacitance ($f = 1 \text{ MHz}$, $T = 25^\circ\text{C}$)⁽¹⁾

	Typ	Max	Units	Conditions
C_{IN}	4	8	pF	$V_{IN} = 0V$
C_{OUT}	8	12	pF	$V_{OUT} = 0V$

Note: 1. Typical values for nominal supply voltage. This parameter is only sampled and is not 100% tested.

Programming Waveforms (1)

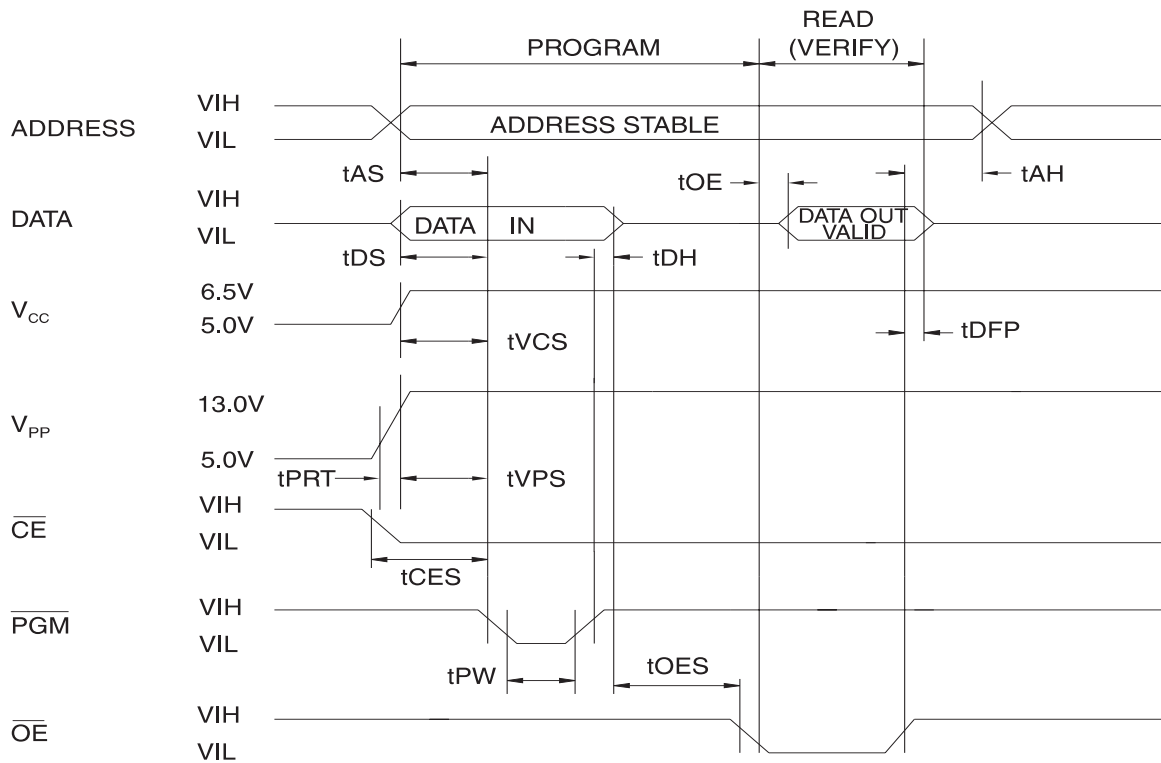

- Notes:
1. The Input Timing Reference is 0.8V for V_{IL} and 2.0V for V_{IH} .
 2. t_{OE} and t_{DFP} are characteristics of the device but must be accommodated by the programmer.
 3. When programming the AT27LV020A a 0.1 μ F capacitor is required across V_{PP} and ground to suppress spurious voltage transients.

DC Programming Characteristics

$T_A = 25 \pm 5^\circ\text{C}$, $V_{CC} = 6.5 \pm 0.25\text{V}$, $V_{PP} = 13.0 \pm 0.25\text{V}$

Symbol	Parameter	Test Conditions	Limits		Units
			Min	Max	
I_{LI}	Input Load Current	$V_{IN} = V_{IL}, V_{IH}$		± 10	μA
V_{IL}	Input Low Level		-0.6	0.8	V
V_{IH}	Input High Level		2.0	$V_{CC} + 0.5$	V
V_{OL}	Output Low Voltage	$I_{OL} = 2.1 \text{ mA}$		0.4	V
V_{OH}	Output High Voltage	$I_{OH} = -400 \mu\text{A}$	2.4		V
I_{CC2}	V_{CC} Supply Current (Program and Verify)			40	mA
I_{PP2}	V_{PP} Supply Current	$\overline{CE} = \overline{PGM} = V_{IL}$		20	mA
V_{ID}	A9 Product Identification Voltage		11.5	12.5	V



AC Programming Characteristics

$T_A = 25 \pm 5^\circ\text{C}$, $V_{CC} = 6.5 \pm 0.25\text{V}$, $V_{PP} = 13.0 \pm 0.25\text{V}$

Symbol	Parameter	Test Conditions* (1)	Limits		Units
			Min	Max	
t_{AS}	Address Setup Time		2		μs
t_{CES}	\overline{CE} Setup Time		2		μs
t_{OES}	\overline{OE} Setup Time		2		μs
t_{DS}	Data Setup Time		2		μs
t_{AH}	Address Hold Time		0		μs
t_{DH}	Data Hold Time		2		μs
t_{DFP}	\overline{OE} High to Output Float Delay		0	130	ns
t_{VPS}	V_{PP} Setup Time		2		μs
t_{VCS}	V_{CC} Setup Time		2		μs
t_{PW}	\overline{PGM} Program Pulse Width		95	105	μs
t_{OE}	Data Valid from \overline{OE}			150	ns
t_{PRT}	V_{PP} Pulse Rise Time During Programming		50		ns

*AC Conditions of Test:

Input Rise and Fall Times (10% to 90%).....20 ns
 Input Pulse Levels.....0.45V to 2.4V
 Input Timing Reference Level.....0.8V to 2.0V
 Output Timing Reference Level.....0.8V to 2.0V

- Notes:
- V_{CC} must be applied simultaneously or before V_{PP} and removed simultaneously or after V_{PP}
 - This parameter is only sampled and is not 100% tested. Output Float is defined as the point where data is no longer driven —see timing diagram.
 - Program Pulse width tolerance is $100 \mu\text{sec} \pm 5\%$.

Atmel's 27LV020A Integrated Product Identification Code (1)

Codes	Pins								Hex Data	
	A0	O7	O6	O5	O4	O3	O2	O1		O0
Manufacturer	0	0	0	0	1	1	1	1	0	1E
Device Type	1	1	0	0	0	0	1	1	0	86

Note: 1. The AT27LV020A has the same Product Identification Code as the AT27C020. Both are programming compatible.

Rapid Programming Algorithm

A $100 \mu\text{s}$ \overline{PGM} pulse width is used to program. The address is set to the first location. V_{CC} is raised to 6.5V and V_{PP} is raised to 13.0V. Each address is first programmed with one $100 \mu\text{s}$ \overline{PGM} pulse without verification. Then a verification/reprogramming loop is executed for each address. In the event a byte fails to pass verification, up to 10 successive $100 \mu\text{s}$ pulses are applied with a verification after each pulse. If the byte fails to verify after 10 pulses have been applied, the part is considered failed. After the byte verifies properly, the next address is selected until all have been checked. V_{PP} is then lowered to 5.0V and V_{CC} to 5.0V. All bytes are read again and compared with the original data to determine if the device passes or fails.

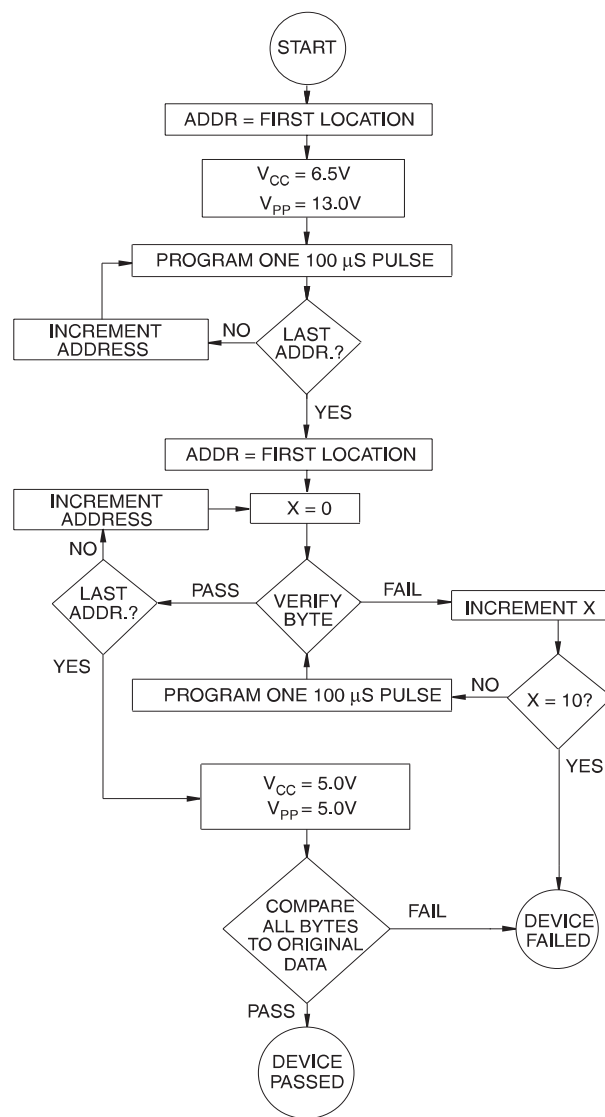

Ordering Information

t _{ACC} (ns)	I _{CC} (mA) V _{CC} = 3.6V		Ordering Code	Package	Operation Range
	Active	Standby			
90	8	0.02	AT27LV020A-90JC	32J	Commercial (0°C to 70°C)
			AT27LV020A-90TC	32T	
			AT27LV020A-90VC	32V	
	8	0.02	AT27LV020A-90JI	32J	Industrial (-40°C to 85°C)
			AT27LV020A-90TI	32T	
			AT27LV020A-90VI	32V	
120	8	0.02	AT27LV020A-12JC	32J	Commercial (0°C to 70°C)
			AT27LV020A-12TC	32T	
			AT27LV020A-12VC	32V	
	8	0.02	AT27LV020A-12JI	32J	Industrial (-40°C to 85°C)
			AT27LV020A-12TI	32T	
			AT27LV020A-12VI	32V	
150	8	0.02	AT27LV020A-15JC	32J	Commercial (0°C to 70°C)
			AT27LV020A-15TC	32T	
			AT27LV020A-15VC	32V	
	8	0.02	AT27LV020A-15JI	32J	Industrial (-40°C to 85°C)
			AT27LV020A-15TI	32T	
			AT27LV020A-15VI	32V	

Package Type	
32J	32 Lead, Plastic J-Leaded Chip Carrier (PLCC)
32T	32 Lead, Plastic Thin Small Outline Package (TSOP) 8 x 20 mm
32V	32 Lead, Plastic Thin Small Outline Package (VSOP) 8 x 14 mm

This datasheet has been downloaded from:

www.DatasheetCatalog.com

Datasheets for electronic components.



LittleDiode supplies new, hard to find or obsolete electronic components and semiconductors all over the world.

With over two million different components listed you are sure to find the part you need.

Feel free to visit us today at our online store:

LittleDiode.com

Looking forward to providing you with the best possible service.