

## Features

- Ideal Rewriteable Attribute Memory
- Simple Write Operation
  - Self-Timed Byte Writes
  - On-chip Address and Data Latch for SRAM-like Write Operation
  - Fast Write Cycle Time - 1 ms
  - 5-Volt-Only Nonvolatile Writes
- End of Write Detection
  - RDY/BUSY Output
  - DATA Polling
- High Reliability
  - Endurance: 100,000 Write Cycles
  - Data Retention: 10 Years Minimum
- Single 5-Volt Supply for Read and Write
- Very Low Power
  - 30 mA Active Current
  - 100  $\mu$ A Standby Current

## Description

The AT28C16-T is the ideal nonvolatile attribute memory: it is a low power, 5-volt-only byte writeable nonvolatile memory (E<sup>2</sup>PROM). Standby current is typically less than 100  $\mu$ A. The AT28C16-T is written like a Static RAM, eliminating complex programming algorithms. The fast write cycle times of 1 ms, allow quick card reconfiguration in-system. Data retention is specified as 10 years minimum, precluding the necessity for batteries. Three access times have been specified to allow for varying layers of buffering between the memory and the PCMCIA interface.

The AT28C16-T is accessed like a Static RAM for read and write operations. During a byte write, the address and data are latched internally. Following the initiation of a write cycle, the device will go to a busy state and automatically write the latched data using an internal control timer. The device provides two methods for detecting the end of a write cycle; the RDY/BUSY output and DATA POLLING of I/O<sub>7</sub>.

**16K (2K x 8)  
PCMCIA  
Nonvolatile  
Attribute  
Memory**

## Pin Configurations

Pin Name	Function
A0 - A10	Addresses
$\overline{\text{CE}}$	Chip Enable
$\overline{\text{OE}}$	Output Enable
$\overline{\text{WE}}$	Write Enable
I/O0 - I/O7	Data Inputs/Outputs
RDY/ $\overline{\text{BSY}}$	Ready/Busy Output
NC	No Connect

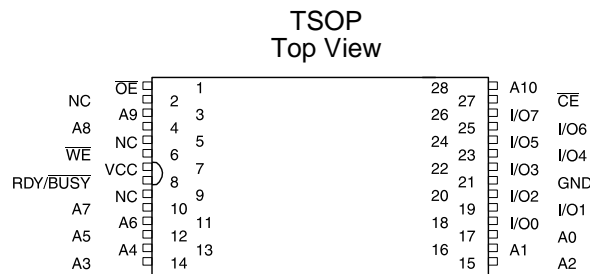

## Block Diagram

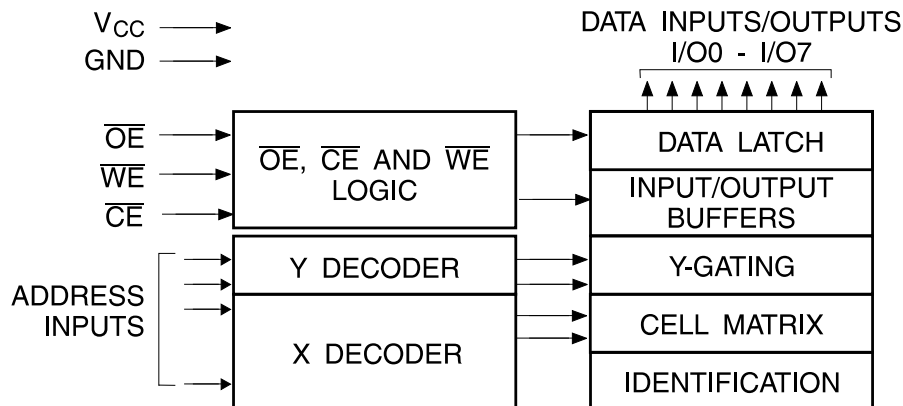

## Absolute Maximum Ratings\*

Temperature Under Bias.....	-55°C to +125°C
Storage Temperature.....	-65°C to +125°C
All Input Voltages (including NC Pins) with Respect to Ground .....	-0.6V to +6.25V
All Output Voltages with Respect to Ground .....	-0.6V to $V_{CC} + 0.6V$
Voltage on $\overline{OE}$ and A9 with Respect to Ground .....	-0.6V to +13.5V

\*NOTICE: Stresses beyond those listed under "Absolute Maximum Ratings" may cause permanent damage to the device. This is a stress rating only and functional operation of the device at these or any other conditions beyond those indicated in the operational sections of this specification is not implied. Exposure to absolute maximum rating conditions for extended periods may affect device reliability.

## Device Operation

**READ:** The AT28C16-T is accessed like a Static RAM. When  $\overline{CE}$  and  $\overline{OE}$  are low and  $\overline{WE}$  is high, the data stored at the memory location determined by the address pins is asserted on the outputs. The outputs are put in a high impedance state whenever  $\overline{CE}$  or  $\overline{OE}$  is high. This dual-line control gives designers increased flexibility in preventing bus contention.

**BYTE WRITE:** Writing data into the AT28C16-T is similar to writing into a Static RAM. A low pulse on  $\overline{WE}$  or  $\overline{CE}$  input with  $\overline{OE}$  high and  $\overline{CE}$  or  $\overline{WE}$  low (respectively) initiates a byte write. The address is latched on the falling edge of  $\overline{WE}$  or  $\overline{CE}$  (whichever occurs last) and the data is latched on the rising edge of  $\overline{WE}$  or  $\overline{CE}$  (whichever occurs first). Once a byte write is started it will automatically time itself to completion. For the AT28C16-T the write cycle time is 1 ms maximum. Once a programming operation has been initiated and for the duration of t<sub>wc</sub>, a read operation will effectively be a polling operation.

**READY/BUSY:** Pin 1 is an open drain READY/BUSY output that indicates the current status of the self-timed internal write cycle. READY/BUSY is actively pulled low during the write cycle and is released at the completion of the write. The open drain output allows OR-tying of several devices to a common interrupt input.

**DATA POLLING:** The AT28C16-T also provides  $\overline{DATA}$  polling to signal the completion of a write cycle. During a write cycle, an attempted read of the the data being written results in the complement of that data for I/O<sub>7</sub> (the other outputs are indeterminate). When the write cycle is finished, true data appears on all outputs.

**WRITE PROTECTION:** Inadvertent writes to the device are protected against in the following ways: (a)  $V_{CC}$  sense— if  $V_{CC}$  is below 3.8V (typical) the write function is inhibited; (b)  $V_{CC}$  power on delay— once  $V_{CC}$  has reached 3.8V the device will automatically time out 5 ms (typical) before allowing a byte write; (c) Write Inhibit— holding any one of  $\overline{OE}$  low,  $\overline{CE}$  high or  $\overline{WE}$  high inhibits byte write cycles.

**CHIP CLEAR:** The contents of the entire memory of the AT28C16-T may be set to the high state by the Chip Clear operation. By setting  $\overline{CE}$  low and  $\overline{OE}$  to 12V, the chip is cleared when a 10ms low pulse is applied to  $\overline{WE}$ .

**DEVICE IDENTIFICATION:** An extra 32-bytes of E<sup>2</sup>PROM memory are available to the user for device identification. By raising A<sub>9</sub> to 12V (± 0.5V) and using address locations 7E0H to 7FFH the additional bytes may be written to or read from in the same manner as the regular memory array.



## DC and AC Operating Range

AT28C16-15T		
Operating Temperature (Case)	Com.	0°C - 70°C
	Ind.	-40°C - 85°C
VCC Power Supply		5V ± 10%

## Operating Modes

Mode	$\overline{CE}$	$\overline{OE}$	$\overline{WE}$	I/O
Read	V <sub>IL</sub>	V <sub>IL</sub>	V <sub>IH</sub>	D <sub>OUT</sub>
Write (2)	V <sub>IL</sub>	V <sub>IH</sub>	V <sub>IL</sub>	D <sub>IN</sub>
Standby/Write Inhibit	V <sub>IH</sub>	X <sup>(1)</sup>	X	High Z
Write Inhibit	X	X	V <sub>IH</sub>	
Write Inhibit	X	V <sub>IL</sub>	X	
Output Disable	X	V <sub>IH</sub>	X	High Z
Chip Erase	V <sub>IL</sub>	V <sub>H</sub> <sup>(3)</sup>	V <sub>IL</sub>	High Z

Notes: 1. X can be V<sub>IL</sub> or V<sub>IH</sub>.

2. Refer to AC Programming Waveforms.

3. V<sub>H</sub> = 12.0V ± 0.5V.

## DC Characteristics

Symbol	Parameter	Condition	Min	Max	Units
I <sub>LI</sub>	Input Load Current	V <sub>IN</sub> = 0V to V <sub>CC</sub> + 1V		10	μA
I <sub>LO</sub>	Output Leakage Current	V <sub>I/O</sub> = 0V to V <sub>CC</sub>		10	μA
I <sub>SB1</sub>	VCC Standby Current CMOS	$\overline{CE} = V_{CC} - 0.3V$ to V <sub>CC</sub> + 1.0V		100	μA
I <sub>SB2</sub>	VCC Standby Current TTL	$\overline{CE} = 2.0V$ to V <sub>CC</sub> + 1.0V	Com.	2	mA
			Ind.	3	mA
I <sub>CC</sub>	VCC Active Current	f = 5 MHz; I <sub>OUT</sub> = 0 mA	Com.	30	mA
			Ind.	45	mA
V <sub>IL</sub>	Input Low Voltage			0.8	V
V <sub>IH</sub>	Input High Voltage		2.0		V
V <sub>OL</sub>	Output Low Voltage	I <sub>OL</sub> = 2.1 mA		.4	V
V <sub>OH</sub>	Output High Voltage	I <sub>OH</sub> = -400 μA	2.4		V

## AC Read Characteristics

PCMCIA Symbol	Atmel Symbol	Parameter	AT28C16-15T		Units
			Min	Max	
$t_C$ (R)	$t_{RC}$	Read Cycle Time	150		ns
$t_A$ (A)	$t_{ACC}$	Address Access Time		150	ns
$t_A$ (CE)	$t_{CE}^{(1)}$	$\overline{CE}$ Access Time		150	ns
$t_A$ (OE)	$t_{OE}^{(2)}$	$\overline{OE}$ Access Time	0	75	ns
$t_{EN}$ (CE)	$t_{LZ}^{(4)}$	Output Enable Time From $\overline{CE}$	0		ns
$t_{EN}$ (OE)	$t_{OLZ}^{(4)}$	Output Enable Time From $\overline{OE}$	0		ns
$t_V$ (A)	$t_{OH}$	Output Hold Time	0		ns
$t_{DIS}$ (CE)	$t_{DF}^{(3,4)}$	Output Disable Time From $\overline{CE}$	0	50	ns
$t_{DIS}$ (OE)	$t_{DF}^{(3,4)}$	Output Disable Time From $\overline{OE}$	0	50	ns

## AC Read Waveforms (1, 2, 3, 4)

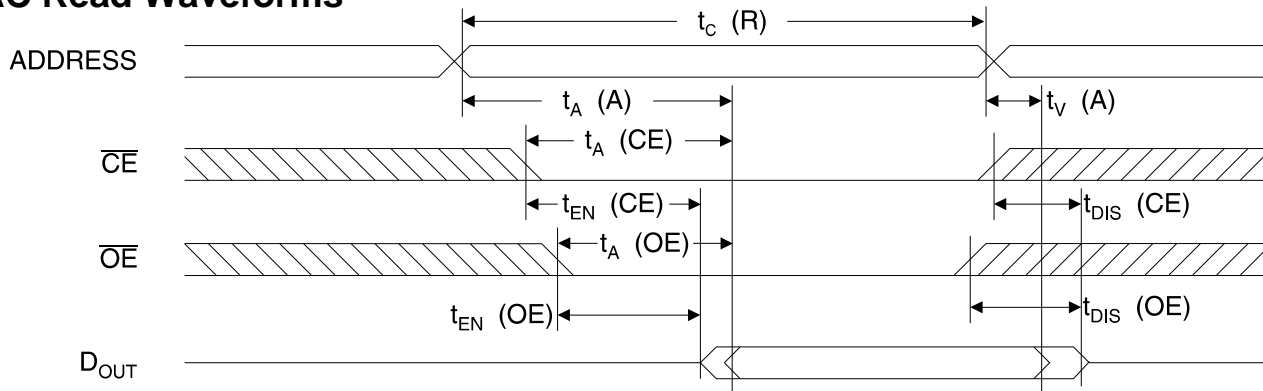

- Notes:
- $\overline{CE}$  may be delayed up to  $t_{ACC} - t_{CE}$  after the address transition without impact on  $t_{ACC}$ .
  - $\overline{OE}$  may be delayed up to  $t_{CE} - t_{OE}$  after the falling edge of  $\overline{CE}$  without impact on  $t_{CE}$  or by  $t_{ACC} - t_{OE}$  after an address change without impact on  $t_{ACC}$ .

- $t_{DF}$  is specified from  $\overline{OE}$  or  $\overline{CE}$  whichever occurs first ( $C_L = 5$  pF).
- This parameter is characterized and is not 100% tested.

## Input Test Waveforms and Measurement Level

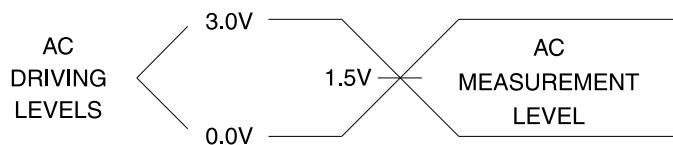

$t_R, t_F < 5$  ns

## Pin Capacitance ( $f = 1$ MHz, $T = 25^\circ\text{C}$ ) <sup>(1)</sup>

	Typ	Max	Units	Conditions
$C_{IN}$	4	6	pF	$V_{IN} = 0V$
$C_{OUT}$	8	12	pF	$V_{OUT} = 0V$

Note: 1. This parameter is characterized and is not 100% tested.

## Output Test Load

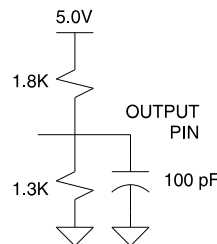

## AC Write Characteristics

PCMCIA Symbol	Atmel Symbol	Parameter	Min	Max	Units
$t_{SU} (A)$	$t_{AS}$	Address Setup Time	10		ns
$t_{SU} (OE-WE)$	$t_{OES}$	Output Disable Time To $\overline{WE}$	10		ns
$t_{SU} (CE-WE)$	$t_{CS}$	Chip Enable Time To $\overline{WE}$	0		ns
$t_W (WE)$	$t_{WP}$	Write Enable Pulse Width	100	1000	ns
$t_{SU} (D-WEH)$	$t_{DS}$	Data Setup To $\overline{WE}$ High	50		ns
$t_H (A)$	$t_{AH}$	Address Hold Time From $\overline{WE}$	50		ns
$t_H (D)$	$t_{DH}$	Data Hold Time From $\overline{WE}$ High	10		ns
$t_H (OE-WE)$	$t_{OEH}$	Output Enable Hold Time From $\overline{WE}$ High	10		ns
$t_H (CE-WE)$	$t_{CH}$	Chip Enable Hold Time From $\overline{WE}$ High	0		ns
$t_D (B)$	$t_{DB}$	Delay From $\overline{WE}$ High To $\overline{BUSY}$ Asserted		50	ns
$t_C (W)$	$t_{WC}$	Write Cycle Time		1	ms

## AC Write Waveforms

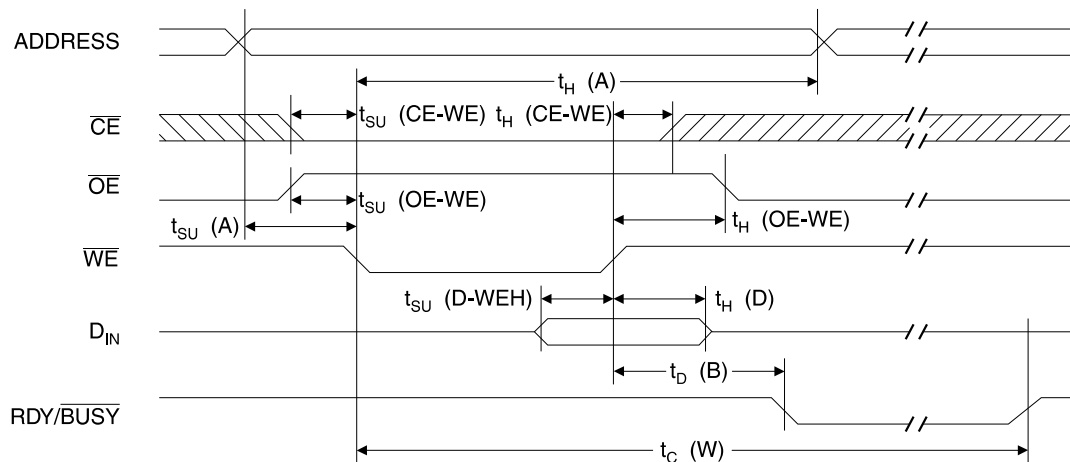

### Data Polling Waveforms

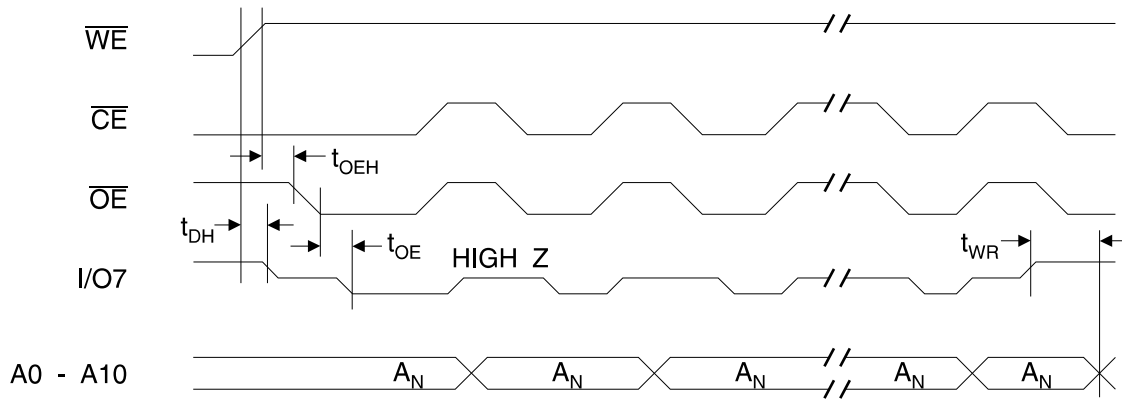

Note: 1. Data Polling AC Timing Characteristics are the same as the AC Read Characteristics.

### Chip Erase Waveforms

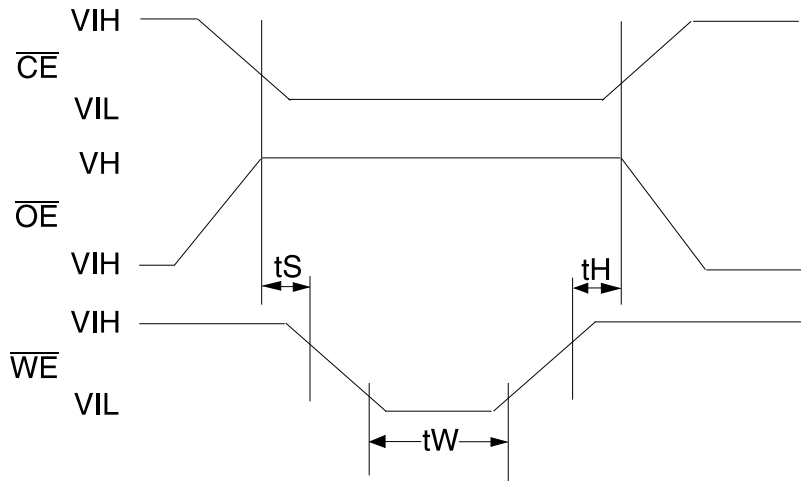

$t_S = t_H = 1 \mu\text{sec (min.)}$   
 $t_W = 10 \text{ msec (min.)}$   
 $V_H = 12.0 \pm 0.5V$



## Ordering Information <sup>(1)</sup>

t <sub>ACC</sub> (ns)	I <sub>CC</sub> (mA)		Ordering Code	Package	Operation Range
	Active	Standby			
150	30	0.1	AT28C16-15TC	28T	Commercial (0°C to 70°C)
	45	0.1	AT28C16-15TI	28T	Industrial (-40°C to 85°C)

- Notes: 1. See Valid Part Number table below.  
2. The 28C16 200 ns and 250 ns speed selections have been removed from valid selections table and are replaced by the faster 150 ns T<sub>AA</sub> offering.

## Valid Part Numbers

The following table lists standard Atmel products that can be ordered.

Device Numbers	Speed	Package and Temperature Combinations
AT28C16	15	TC, TI

Package Type	
28T	28 Lead, Plastic Thin Small Outline Package (TSOP)

This datasheet has been downloaded from:

[www.DatasheetCatalog.com](http://www.DatasheetCatalog.com)

Datasheets for electronic components.



LittleDiode supplies new, hard to find or obsolete electronic components and semiconductors all over the world.

With over two million different components listed you are sure to find the part you need.

Feel free to visit us today at our online store:

[LittleDiode.com](http://LittleDiode.com)

Looking forward to providing you with the best possible service.