

## Features

- Single 3.3V ± 10% Supply
- 3-Volt-Only Read and Write Operation
- Software-Protected Programming
- Low Power Dissipation
  - 15 mA Active Current
  - 20 µA CMOS Standby Current
- Fast Read Access Time – 200 ns
- Automatic Page Write Operation
  - Internal Address and Data Latches for 64-Bytes
  - Internal Control Timer
- Fast Write Cycle Times
  - Page Write Cycle Time: 10 ms Maximum
  - 1 to 64-Byte Page Write Operation
- DATA Polling for End of Write Detection
- High Reliability CMOS Technology
  - Endurance: 10,000 Cycles
  - Data Retention: 10 Years
- JEDEC Approved Byte-Wide Pinout
- Commercial and Industrial Temperature Ranges

## Description

The AT28LV64B is a high-performance electrically erasable programmable read only memory (EEPROM). Its 64K of memory is organized as 8,192 words by 8 bits. Manufactured with Atmel's advanced nonvolatile CMOS technology, the device offers access times to 200 ns with power dissipation of just 54 mW. When the device is deselected, the CMOS standby current is less than 20 µA.

The AT28LV64B is accessed like a static RAM for the read or write cycle without the need for external components. The device contains a 64-byte page register to allow

*(continued)*

## Pin Configurations

Pin Name	Function
A0 - A12	Addresses
$\overline{CE}$	Chip Enable
$\overline{OE}$	Output Enable
$\overline{WE}$	Write Enable
I/O0 - I/O7	Data Inputs/Outputs
NC	No Connect
DC	Don't Connect

PDIP, SOIC  
Top View

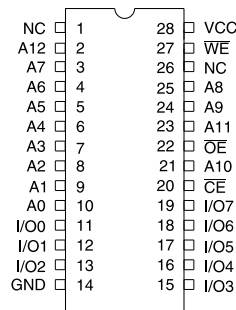

PLCC  
Top View

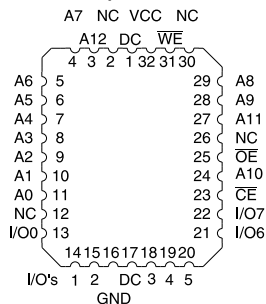

Note: PLCC package pins 1 and 17 are DON'T CONNECT.

TSOP  
Top View



**64K (8K x 8)  
Low Voltage  
CMOS  
E<sup>2</sup>PROM with  
Page Write and  
Software Data  
Protection**

## Description (Continued)

writing of up to 64-bytes simultaneously. During a write cycle, the addresses and 1 to 64-bytes of data are internally latched, freeing the address and data bus for other operations. Following the initiation of a write cycle, the device will automatically write the latched data using an internal control timer. The end of a write cycle can be detected by  $\overline{\text{DATA}}$  polling of I/O7. Once the end of a write cycle has been detected a new access for a read or write can begin.

Atmel's 28LV64B has additional features to ensure high quality and manufacturability. The device utilizes internal error correction for extended endurance and improved data retention characteristics. A software data protection mechanism guards against inadvertent writes. The device also includes an extra 64-bytes of E<sup>2</sup>PROM for device identification or tracking.

## Block Diagram

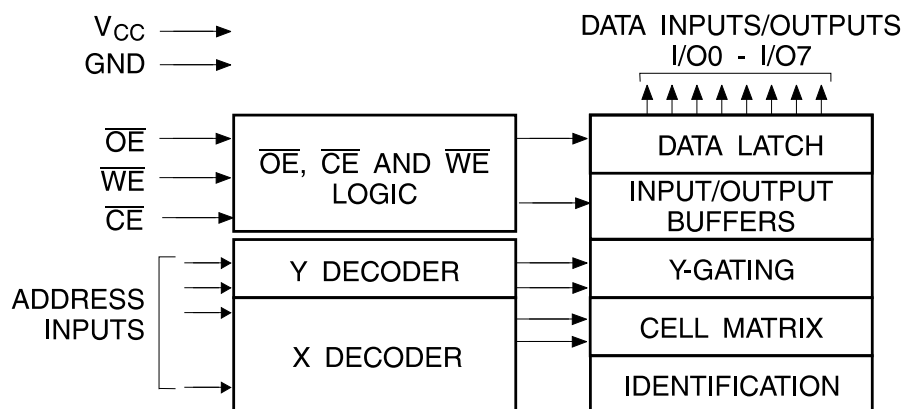

## Absolute Maximum Ratings\*

Temperature Under Bias.....	-55°C to +125°C
Storage Temperature.....	-65°C to +150°C
All Input Voltages (including NC Pins) with Respect to Ground .....	-0.6V to +6.25V
All Output Voltages with Respect to Ground .....	-0.6V to $V_{CC} + 0.6V$
Voltage on $\overline{\text{OE}}$ and A9 with Respect to Ground .....	-0.6V to +13.5V

\*NOTICE: Stresses beyond those listed under "Absolute Maximum Ratings" may cause permanent damage to the device. This is a stress rating only and functional operation of the device at these or any other conditions beyond those indicated in the operational sections of this specification is not implied. Exposure to absolute maximum rating conditions for extended periods may affect device reliability.

## Device Operation

**READ:** The AT28LV64B is accessed like a static RAM. When  $\overline{CE}$  and  $\overline{OE}$  are low and  $\overline{WE}$  is high, the data stored at the memory location determined by the address pins is asserted on the outputs. The outputs are put in the high impedance state when either  $\overline{CE}$  or  $\overline{OE}$  is high. This dual-line control gives designers flexibility in preventing bus contention in their systems.

**BYTE WRITE:** A low pulse on the  $\overline{WE}$  or  $\overline{CE}$  input with  $\overline{CE}$  or  $\overline{WE}$  low (respectively) and  $\overline{OE}$  high initiates a write cycle. The address is latched on the falling edge of  $\overline{CE}$  or  $\overline{WE}$ , whichever occurs last. The data is latched by the first rising edge of  $\overline{CE}$  or  $\overline{WE}$ . Once a byte write has been started, it will automatically time itself to completion. Once a programming operation has been initiated and for the duration of  $t_{wc}$ , a read operation will effectively be a polling operation.

**PAGE WRITE:** The page write operation of the AT28LV64B allows 1 to 64-bytes of data to be written into the device during a single internal programming period. A page write operation is initiated in the same manner as a byte write; the first byte written can then be followed by 1 to 63 additional bytes. Each successive byte must be written within 100  $\mu s$  ( $t_{BLC}$ ) of the previous byte. If the  $t_{BLC}$  limit is exceeded, the AT28LV64B will cease accepting data and commence the internal programming operation. All bytes during a page write operation must reside on the same page as defined by the state of the A6 to A12 inputs. For each  $\overline{WE}$  high to low transition during the page write operation, A6 to A12 must be the same.

The A0 to A5 inputs specify which bytes within the page are to be written. The bytes may be loaded in any order and may be altered within the same load period. Only bytes which are specified for writing will be written; unnecessary cycling of other bytes within the page does not occur.

**DATA POLLING:** The AT28LV64B features  $\overline{DATA}$  Polling to indicate the end of a write cycle. During a byte or page write cycle an attempted read of the last byte written will result in the complement of the written data to be presented on I/O7. Once the write cycle has been completed, true data is valid on all outputs, and the next write cycle may begin.  $\overline{DATA}$  Polling may begin at anytime during the write cycle.

**TOGGLE BIT:** In addition to  $\overline{DATA}$  Polling, the AT28LV64B provides another method for determining the end of a write cycle. During the write operation, successive attempts to read data from the device will result in I/O6 toggling between one and zero. Once the write has completed, I/O6 will stop toggling and valid data will be

read. Reading the toggle bit may begin at any time during the write cycle.

**DATA PROTECTION:** If precautions are not taken, inadvertent writes may occur during transitions of the host system power supply. Atmel has incorporated both hardware and software features that will protect the memory against inadvertent writes.

**HARDWARE PROTECTION:** Hardware features protect against inadvertent writes to the AT28LV64B in the following ways: (a)  $V_{CC}$  power-on delay—once  $V_{CC}$  has reached 1.8V (typical) the device will automatically time out 10 ms (typical) before allowing a write; (b) write inhibit—holding any one of  $\overline{OE}$  low,  $\overline{CE}$  high or  $\overline{WE}$  high inhibits write cycles; (c) noise filter—pulses of less than 15 ns (typical) on the  $\overline{WE}$  or  $\overline{CE}$  inputs will not initiate a write cycle.

**SOFTWARE DATA PROTECTION:** A software-controlled data protection feature has been implemented on the AT28LV64B. Software data protection (SDP) helps prevent inadvertent writes from corrupting the data in the device. SDP can prevent inadvertent writes during power-up and power-down as well as any other potential periods of system instability.

*The AT28LV64B can only be written using the software data protection feature. A series of three write commands to specific addresses with specific data must be presented to the device before writing in the byte or page mode. The same three write commands must begin each write operation. All software write commands must obey the page mode write timing specifications. The data in the 3-byte command sequence is not written to the device; the addresses in the command sequence can be utilized just like any other location in the device.*

Any attempt to write to the device without the 3-byte sequence will start the internal write timers. No data will be written to the device; however, for the duration of  $t_{wc}$ , read operations will effectively be polling operations.

**DEVICE IDENTIFICATION:** An extra 64-bytes of E<sup>2</sup>PROM memory are available to the user for device identification. By raising A9 to 12V  $\pm$  0.5V and using address locations 7FC0H to 7FFFH, the additional bytes may be written to or read from in the same manner as the regular memory array.

## DC and AC Operating Range

		AT28LV64B-20	AT28LV64B-25
Operating Temperature (Case)	Com.	0°C - 70°C	0°C - 70°C
	Ind.	-40°C - 85°C	-40°C - 85°C
V <sub>CC</sub> Power Supply		3.3V ± 10%	3.3V ± 10%

## Operating Modes

Mode	$\overline{CE}$	$\overline{OE}$	$\overline{WE}$	I/O
Read	V <sub>IL</sub>	V <sub>IL</sub>	V <sub>IH</sub>	DOUT
Write <sup>(2)</sup>	V <sub>IL</sub>	V <sub>IH</sub>	V <sub>IL</sub>	DIN
Standby/Write Inhibit	V <sub>IH</sub>	X <sup>(1)</sup>	X	High Z
Write Inhibit	X	X	V <sub>IH</sub>	
Write Inhibit	X	V <sub>IL</sub>	X	
Output Disable	X	V <sub>IH</sub>	X	High Z
Chip Erase	V <sub>IL</sub>	V <sub>H</sub> <sup>(3)</sup>	V <sub>IL</sub>	High Z

Notes: 1. X can be V<sub>IL</sub> or V<sub>IH</sub>.

2. Refer to AC Programming Waveforms.

3. V<sub>H</sub> = 12.0V ± 0.5V.

## DC Characteristics

Symbol	Parameter	Condition	Min	Max	Units
I <sub>LI</sub>	Input Load Current	V <sub>IN</sub> = 0V to V <sub>CC</sub> + 1V		10	μA
I <sub>LO</sub>	Output Leakage Current	V <sub>I/O</sub> = 0V to V <sub>CC</sub>		10	μA
I <sub>SB</sub>	V <sub>CC</sub> Standby Current CMOS	$\overline{CE} = V_{CC} - 0.3V$ to V <sub>CC</sub> + 1V	Com.	20	μA
			Ind.	50	μA
I <sub>CC</sub>	V <sub>CC</sub> Active Current	f = 5 MHz; I <sub>OUT</sub> = 0 mA		15	mA
V <sub>IL</sub>	Input Low Voltage			0.6	V
V <sub>IH</sub>	Input High Voltage		2.0		V
V <sub>OL</sub>	Output Low Voltage	I <sub>OL</sub> = 1.6 mA		0.45	V
V <sub>OH</sub>	Output High Voltage	I <sub>OH</sub> = -100 μA	2.0		V

## AC Read Characteristics

Symbol	Parameter	AT28LV64B-20		AT28LV64B-25		Units
		Min	Max	Min	Max	
$t_{ACC}$	Address to Output Delay		200		250	ns
$t_{CE}^{(1)}$	$\overline{CE}$ to Output Delay		200		250	ns
$t_{OE}^{(2)}$	$\overline{OE}$ to Output Delay	0	80	0	100	ns
$t_{DF}^{(3,4)}$	$\overline{CE}$ or $\overline{OE}$ to Output Float	0	55	0	60	ns
$t_{OH}$	Output Hold from $\overline{OE}$ , $\overline{CE}$ or Address, whichever occurred first	0		0		ns

## AC Read Waveforms (1, 2, 3, 4)

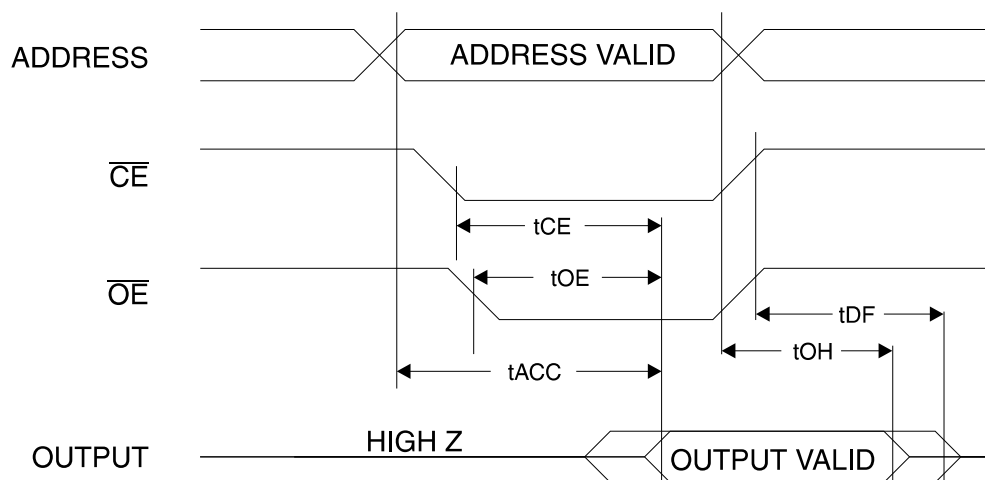

- Notes:
- $\overline{CE}$  may be delayed up to  $t_{ACC} - t_{CE}$  after the address transition without impact on  $t_{ACC}$ .
  - $\overline{OE}$  may be delayed up to  $t_{CE} - t_{OE}$  after the falling edge of  $\overline{CE}$  without impact on  $t_{CE}$  or by  $t_{ACC} - t_{OE}$  after an address change without impact on  $t_{ACC}$ .

- $t_{DF}$  is specified from  $\overline{OE}$  or  $\overline{CE}$ , whichever occurs first ( $C_L = 5 \text{ pF}$ ).
- This parameter is characterized and is not 100% tested.

## Input Test Waveforms and Measurement Level

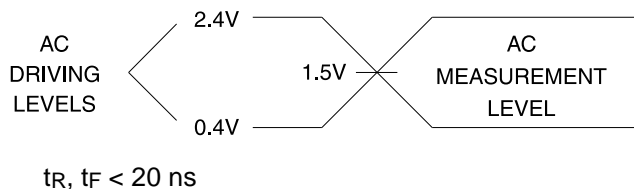

## Output Test Load

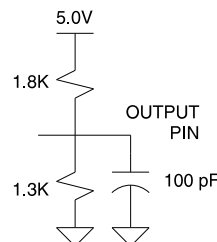

## Pin Capacitance ( $f = 1 \text{ MHz}$ , $T = 25^\circ\text{C}$ ) <sup>(1)</sup>

	Typ	Max	Units	Conditions
$C_{IN}$	4	6	pF	$V_{IN} = 0V$
$C_{OUT}$	8	12	pF	$V_{OUT} = 0V$

Note: 1. This parameter is characterized and is not 100% tested.

## AC Write Characteristics

Symbol	Parameter	Min	Max	Units
$t_{AS}, t_{OES}$	Address, $\overline{OE}$ Set-up Time	0		ns
$t_{AH}$	Address Hold Time	100		ns
$t_{CS}$	Chip Select Set-up Time	0		ns
$t_{CH}$	Chip Select Hold Time	0		ns
$t_{WP}$	Write Pulse Width ( $\overline{WE}$ or $\overline{CE}$ )	200		ns
$t_{DS}$	Data Set-up Time	100		ns
$t_{DH}, t_{OEH}$	Data, $\overline{OE}$ Hold Time	0		ns
$t_{DV}$	Time to Data Valid	NR <sup>(1)</sup>		
$t_{WPH}$	Write Pulse Width High	100		ns

Notes: 1. NR = No Restriction.

2. All byte write operations must be preceded by the SDP command sequence.

## AC Write Waveforms

### $\overline{WE}$ Controlled

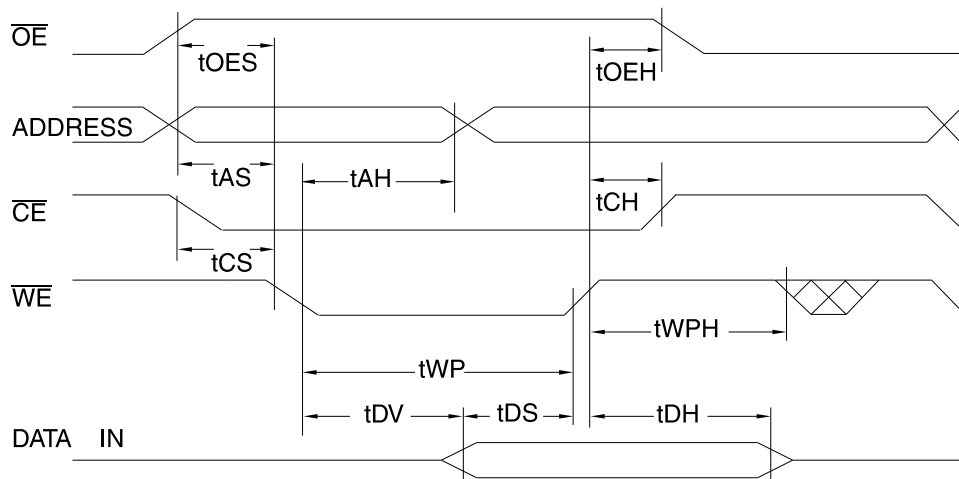

### $\overline{CE}$ Controlled

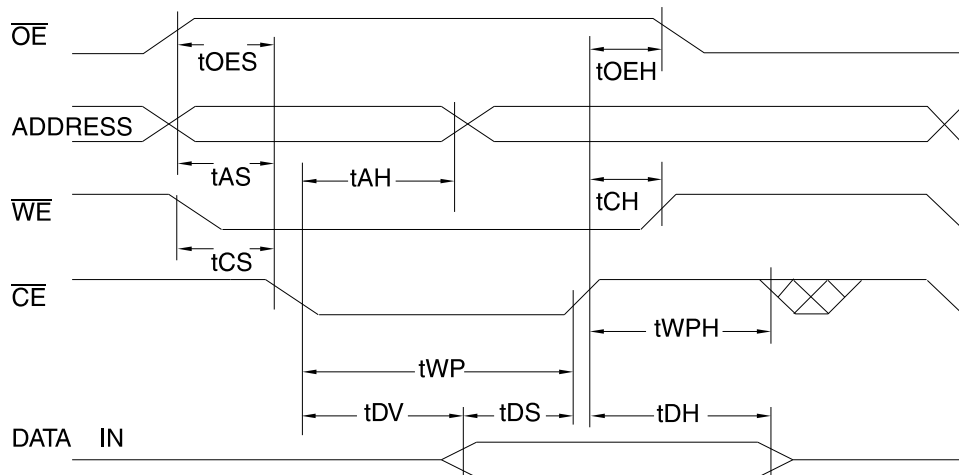

Page Mode Characteristics

Symbol	Parameter	Min	Max	Units
tWC	Write Cycle Time		10	ms
tAS	Address Set-up Time	0		ns
tAH	Address Hold Time	100		ns
tDS	Data Set-up Time	100		ns
tDH	Data Hold Time	0		ns
tWP	Write Pulse Width	200		ns
tBLC	Byte Load Cycle Time		100	μs
tWPH	Write Pulse Width High	100		ns

Write Algorithm <sup>(1)</sup>

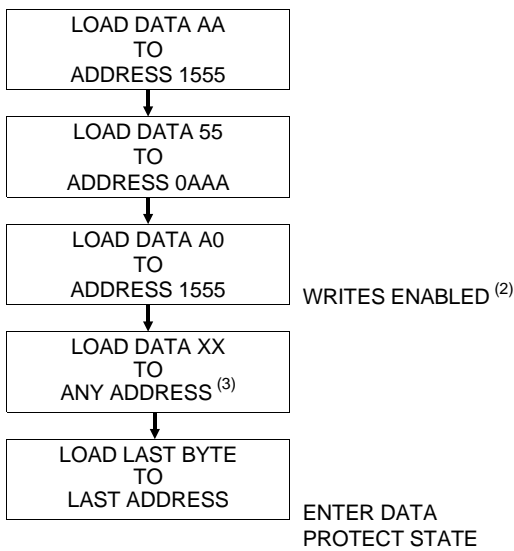

Notes for software program code:

1. Data Format: I/O7 - I/O0 (Hex); Address Format: A12 - A0 (Hex).
2. Data protect state will be re-activated at the end of the write cycle.
3. 1 to 64-bytes of data are loaded.

Software Data Protection Write Cycle Waveforms <sup>(1, 2, 3)</sup>

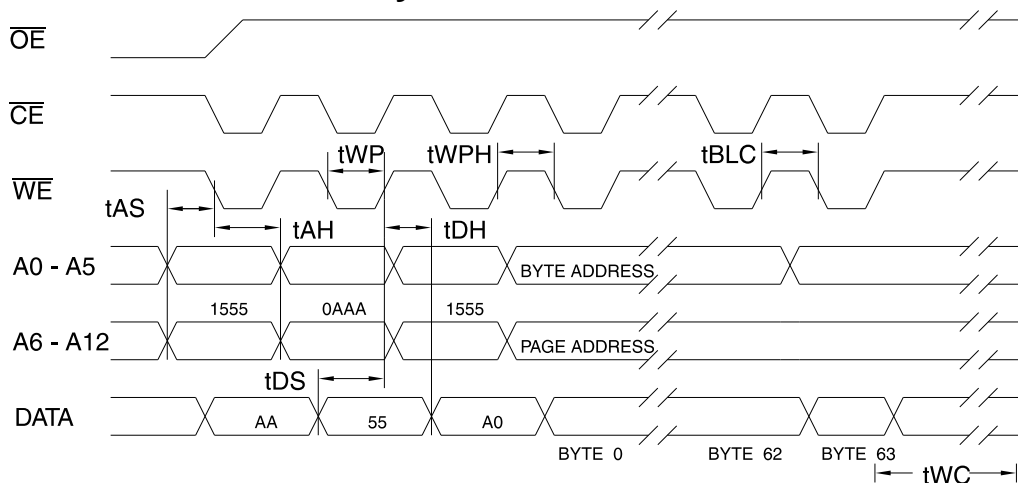

- Notes:
1. A0 - A12 must conform to the addressing sequence for the first three bytes as shown above.
  2. A6 through A12 must specify the same page address during each high to low transition of WE (or CE) after the software code has been entered.
  3. OE must be high only when WE and CE are both low.

## Data Polling Characteristics <sup>(1)</sup>

Symbol	Parameter	Min	Typ	Max	Units
t <sub>DH</sub>	Data Hold Time	0			ns
t <sub>OE<math>\bar{H}</math></sub>	$\overline{OE}$ Hold Time	0			ns
t <sub>OE</sub>	$\overline{OE}$ to Output Delay <sup>(2)</sup>				ns
t <sub>WR</sub>	Write Recovery Time	0			ns

Notes: 1. These parameters are characterized and not 100% tested.

2. See AC Read Characteristics.

## Data Polling Waveforms

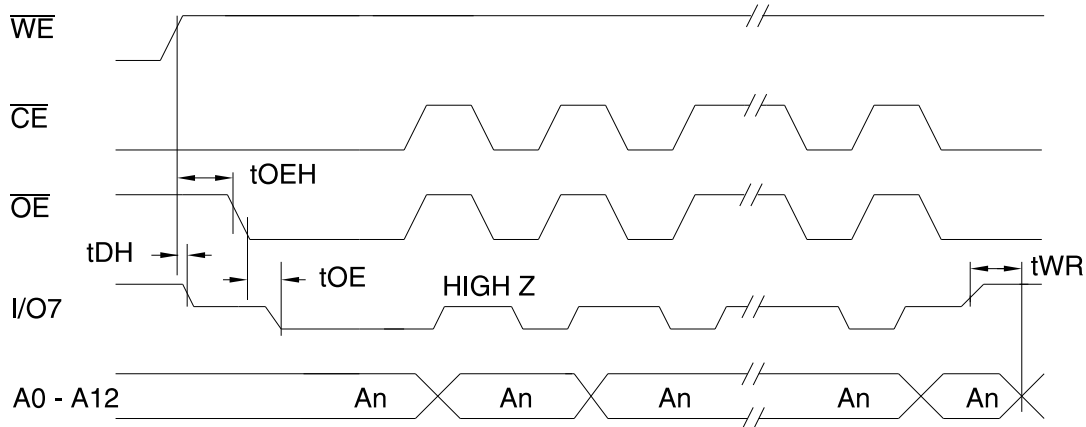

## Toggle Bit Characteristics <sup>(1)</sup>

Symbol	Parameter	Min	Typ	Max	Units
t <sub>DH</sub>	Data Hold Time	10			ns
t <sub>OE<math>\bar{H}</math></sub>	$\overline{OE}$ Hold Time	10			ns
t <sub>OE</sub>	$\overline{OE}$ to Output Delay <sup>(2)</sup>				ns
t <sub>OEHP</sub>	$\overline{OE}$ High Pulse	150			ns
t <sub>WR</sub>	Write Recovery Time	0			ns

Notes: 1. These parameters are characterized and not 100% tested.

2. See AC Read Characteristics.

## Toggle Bit Waveforms

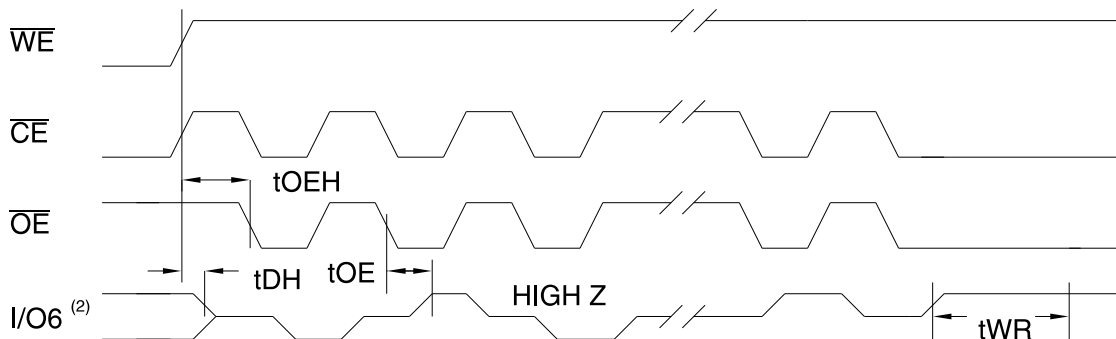

Notes: 1. Toggling either  $\overline{OE}$  or  $\overline{CE}$  or both  $\overline{OE}$  and  $\overline{CE}$  will operate toggle bit.

2. Beginning and ending state of I/O6 will vary.

3. Any address location may be used, but the address should not vary.

## Ordering Information <sup>(1)</sup>

t <sub>ACC</sub> (ns)	I <sub>CC</sub> (mA)		Ordering Code	Package	Operation Range
	Active	Standby			
200	15	0.05	AT28LV64B-20JC AT28LV64B-20PC AT28LV64B-20SC AT28LV64B-20TC	32J 28P6 28S 28T	Commercial (0°C to 70°C)
	15	0.05	AT28LV64B-20JI AT28LV64B-20PI AT28LV64B-20SI AT28LV64B-20TI	32J 28P6 28S 28T	Industrial (-40°C to 85°C)
250	15	0.05	AT28LV64B-25JC AT28LV64B-25PC AT28LV64B-25SC AT28LV64B-25TC	32J 28P6 28S 28T	Commercial (0°C to 70°C)
	15	0.05	AT28LV64B-25JI AT28LV64B-25PI AT28LV64B-25SI AT28LV64B-25TI	32J 28P6 28S 28T	Industrial (-40°C to 85°C)

Note: 1. See Valid Part Number table below.

## Valid Part Numbers

The following table lists standard Atmel products that can be ordered.

Device Numbers	Speed	Package and Temperature Combinations
AT28LV64B	20	JC, JI, PC, PI, SC, SI, TC, TI
AT28LV64B	25	JC, JI, PC, PI, SC, SI, TC, TI

Package Type	
<b>32J</b>	32 Lead, Plastic J-Leaded Chip Carrier (PLCC)
<b>28P6</b>	28 Lead, 0.600" Wide, Plastic Dual Inline Package (PDIP)
<b>28S</b>	28 Lead, 0.300" Wide, Plastic Gull Wing Small Outline (SOIC)
<b>28T</b>	28 Lead, Plastic Thin Small Outline Package (TSOP)

This datasheet has been downloaded from:

[www.DatasheetCatalog.com](http://www.DatasheetCatalog.com)

Datasheets for electronic components.



LittleDiode supplies new, hard to find or obsolete electronic components and semiconductors all over the world.

With over two million different components listed you are sure to find the part you need.

Feel free to visit us today at our online store:

[LittleDiode.com](http://LittleDiode.com)

Looking forward to providing you with the best possible service.