

Features

- Wireless Interface Following the IEEE 802.11b Standard
- Ethernet MAC Unit (EMU) Interfaces with 10/100-Mbit Ethernet Physical through a Standard MII Port
- Inter-networking Unit (INWARM) with Integrated ARM7TDMI® RISC Processor Provides the Bridging Functions between Ethernet and Wireless Interfaces
- WLAN MAC Unit with a Second ARM7TDMI RISC Processor and Integrated 128-byte Transmit and 128-byte Receive FIFOs, for Wireless MAC Layer Functions
- Glueless SRAM Interface for all MAC Operations, Supporting up to 16M Bytes of Common External Memory Shared between Both Processors
- Integrated 2 x 6K x 32-bit Internal SRAM Memory Banks, Used for Each Processor's Program Code and Data Space
- Glueless Flash Memory Interface, Supporting up to 16M Bytes of Nonvolatile Memory for Permanent Storage of Program Code
- Enciphering/Deciphering of Wireless Data On-the-fly Ensures Maximum Privacy of Data
- The Integrated Physical Attachment Interface (PAI), Fully Supports Direct Sequence Spread Spectrum and Frequency Hopping Spread Spectrum (2 Mbps) Physical-layer Interfaces
- The WLAN and Inter-networking Functions Can Be Changed and Updated Easily to New Requirements Since They are Implemented in Microcode
- 3.3V for Core and I/O
- 128-lead Plastic Quad Flat Pack (PQFP) or Thin Quad Flat Pack (TQFP) Package

Block Diagram

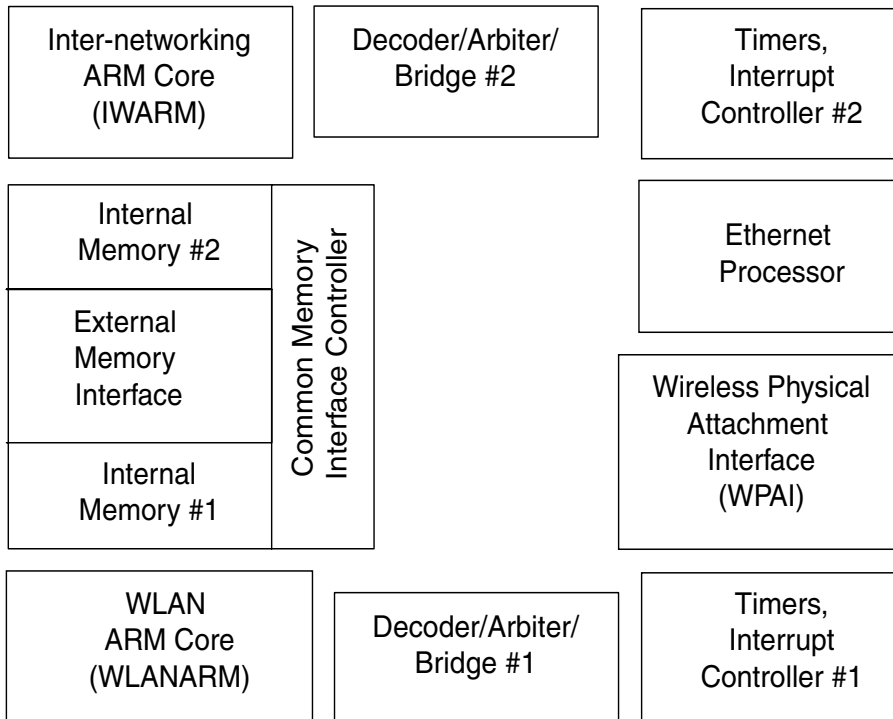

Ethernet to Wireless Bridge-on-a- Chip

AT76C510 VNET-B Summary

Rev. 1650DS-WLAN-01/03



Note: This is a summary datasheet. A complete document is available under NDA. For more information, please contact your local Atmel Sales office.

Overview

Wireless to Ethernet Bridge (VNET-B) is the Inter-networking device for interconnecting a Wireless LAN with other Wireless LANs (WLAN) and legacy LANs.

VNET-B based bridges act as Access Points (AP) to the WLAN and communicate packets that are destined outside the WLAN using IP over Ethernet. In case the WLAN user is mobile, roaming functions are also supported at the VNET-B bridges.

The data transactions over this unified environment are categorized according to the type of end-to-end devices.

End Stations Transactions

When two end stations communicate (irrespective to the type of network they belong) the inter-networking between the different networks should be transparent.

Inter-networking Device Transactions

The VNET-B device implements all necessary communication protocols for supporting inter-networking functions, implements logical grouping of users independent of their physical location and provides secure links by implementing encryption algorithms.



Atmel Headquarters

Corporate Headquarters

2325 Orchard Parkway
San Jose, CA 95131
USA
TEL 1(408) 441-0311
FAX 1(408) 487-2600

Europe

Atmel Sarl
Route des Arsenaux 41
Case Postale 80
CH-1705 Fribourg
Switzerland
TEL (41) 26-426-5555
FAX (41) 26-426-5500

Asia

Room 1219
Chinachem Golden Plaza
77 Mody Road Tsimshatsui
East Kowloon
Hong Kong
TEL (852) 2721-9778
FAX (852) 2722-1369

Japan

9F, Tonetsu Shinkawa Bldg.
1-24-8 Shinkawa
Chuo-ku, Tokyo 104-0033
Japan
TEL (81) 3-3523-3551
FAX (81) 3-3523-7581

Atmel Operations

Memory

2325 Orchard Parkway
San Jose, CA 95131
TEL 1(408) 441-0311
FAX 1(408) 436-4314

Microcontrollers

2325 Orchard Parkway
San Jose, CA 95131
TEL 1(408) 441-0311
FAX 1(408) 436-4314

La Chantrerie
BP 70602
44306 Nantes Cedex 3, France
TEL (33) 2-40-18-18-18
FAX (33) 2-40-18-19-60

ASIC/ASSP/Smart Cards

Zone Industrielle
13106 Rousset Cedex, France
TEL (33) 4-42-53-60-00
FAX (33) 4-42-53-60-01

1150 East Cheyenne Mtn. Blvd.
Colorado Springs, CO 80906
TEL 1(719) 576-3300
FAX 1(719) 540-1759

Scottish Enterprise Technology Park
Maxwell Building
East Kilbride G75 0QR, Scotland
TEL (44) 1355-803-000
FAX (44) 1355-242-743

RF/Automotive

Theresienstrasse 2
Postfach 3535
74025 Heilbronn, Germany
TEL (49) 71-31-67-0
FAX (49) 71-31-67-2340

1150 East Cheyenne Mtn. Blvd.
Colorado Springs, CO 80906
TEL 1(719) 576-3300
FAX 1(719) 540-1759

Biometrics/Imaging/Hi-Rel MPU/ High Speed Converters/RF Datacom

Avenue de Rochepleine
BP 123
38521 Saint-Egreve Cedex, France
TEL (33) 4-76-58-30-00
FAX (33) 4-76-58-34-80

e-mail

literature@atmel.com

Web Site

<http://www.atmel.com>

© Atmel Corporation 2003.

Atmel Corporation makes no warranty for the use of its products, other than those expressly contained in the Company's standard warranty which is detailed in Atmel's Terms and Conditions located on the Company's web site. The Company assumes no responsibility for any errors which may appear in this document, reserves the right to change devices or specifications detailed herein at any time without notice, and does not make any commitment to update the information contained herein. No licenses to patents or other intellectual property of Atmel are granted by the Company in connection with the sale of Atmel products, expressly or by implication. Atmel's products are not authorized for use as critical components in life support devices or systems.

ATMEL® is the registered trademarks of Atmel.

ARM7TDMI® is the registered trademark ARM, Ltd.

Other terms and product names may be the trademarks of others.



Printed on recycled paper.



LittleDiode supplies new, hard to find or obsolete electronic components and semiconductors all over the world.

With over two million different components listed you are sure to find the part you need.

Feel free to visit us today at our online store:

LittleDiode.com

Looking forward to providing you with the best possible service.