



T-25-17

C148

Powerex, Inc., Hillis Street, Youngwood, Pennsylvania 15697 (412) 925-7272
 Powerex Europe, S.A., 428 Avenue G. Durand, BP107, 72003 Le Mans, France (43) 41.14.14

Inverter Grade SCR
63 Amperes RMS
600-1200 Volts/30-40 μ sec

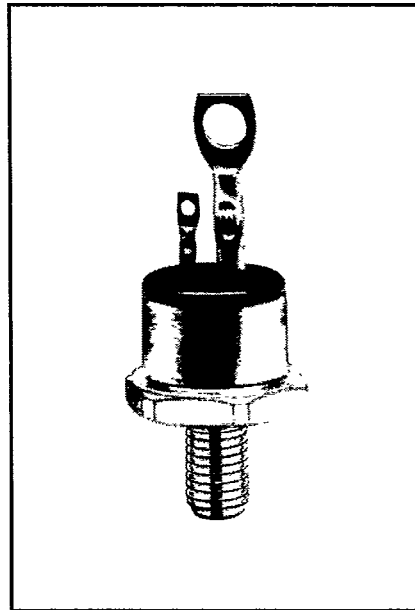
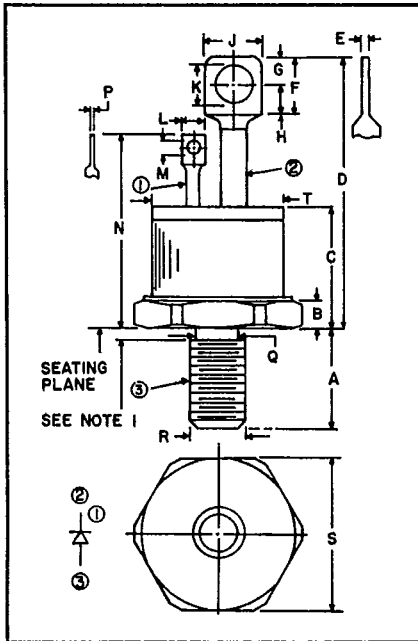

C148
Inverter Grade SCR
63 Amperes/600-1200 Volts/
30-40 μ sec

600-1200 Volts, C148 Outline Drawing
Modified TO-65

Dimensions	Inches		Millimeters	
	Min.	Max.	Min.	Max.
A	.422	.452	10.72	11.47
B	.120	.135	3.05	3.42
C	.534	.565	13.57	14.34
D	1.230	1.290	31.25	32.78
E	.029	0.62	.74	1.56
F	.258	Ref.	6.55	Ref.
G	.138	Ref.	3.50	Ref.
H	.115	—	2.83	—
J	.240	.300	6.10	7.62
K	.169	.182	4.30	4.62
L	.090	.115	2.29	2.91
M	.055	.066	1.40	1.67
N	.831	.901	21.11	22.88
P	.012	—	.31	—
Q	.220	—	5.59	—
R	1/4-28		UNF-2A	
S	.676	.684	17.18	17.36
T	—	.597	—	15.15

Note:
 1 Complete threads to within 2 1/2 thd. of seating plane.
 2. One steel, cadmium plated nut and one steel, cadmi-
 um plated lockwasher supplied with each device.

Description

Powerex Inverter Grade Silicon Controlled Rectifiers (SCR) are designed for applications. These are all-diffused, compression bonded encapsulated (CBE) devices employing the field-proven amplifying (di/namic) gate.

Features:

- Center fired Di/Namic Gate
- High dv/dt With Soft Gate Control
- High Frequency Operation
- Sinusoidal Waveform Operation To 20kHz
- Rectangular Waveform Operation To 20kHz
- Low Dynamic Forward Voltage Drop
- Low Switching Losses At High Frequency

Applications:

- UPS Inverters
- Induction Heating Inverters
- High Frequency Lighting
- Cycloconverters
- Choppers
- DC To DC Conversion

Ordering Information

Example: Select the complete 7 or 8 digit part number you desire from the table — i.e. C148N40 is an 800 Volt, 63 Ampere Inverter Grade SCR, 40 μ s T_q .

Type	Voltage V_{DRM}/V_{RRM}	Code	Turn-Off	
			t_q (μ sec)	Code
C148	600	M	30	30
	800	N	40	40
	1000	P		
	1200	PB		

Note: All voltages not available in all current ratings.



T-25-17

Powerex, Inc., Hills Street, Youngwood, Pennsylvania 15697 (412) 925-7272

Powerex Europe, S.A., 428 Avenue G. Durand, BP107, 72003 Le Mans, France (43) 41.14.14

C148**Inverter Grade SCR**

63 Amperes RMS/600-1200 Volts/30-40 μ sec

Absolute Maximum Ratings

Ratings	Symbol	C148M	C148N	Units
Repetitive Peak Off-State Voltage	V_{DRM}	600	800	Volts
Repetitive Peak Reverse Voltage	V_{RRM}	600	800	Volts
Non-repetitive Peak Reverse Voltage	V_{RSM}	720	960	Volts

Ratings	Symbol	C148P	C148PB	Units
Repetitive Peak Off-State Voltage	V_{DRM}	1000	1200	Volts
Repetitive Peak Reverse Voltage	V_{RRM}	1000	1200	Volts
Non-repetitive Peak Reverse Voltage	V_{RSM}	1200	1440	Volts

C148				
RMS On-State Current	$I_{T(RMS)}$	63		Amperes
Peak One-Cycle Surge (Non-Repetitive) On-State Current (60 Hz) ②	I_{TSM}	700		Amperes
Peak One-Cycle Surge (Non-Repetitive) On-State Current (50 Hz) ②	I_{TSM}	670		Amperes
Critical Rate-of-Rise of On-State Current (Non-Repetitive) ①④⑤	di/dt	100		Amperes/ μ s
Critical Rate-of-Rise of On-State Current (Repetitive)	di/dt	75		Amperes/ μ s
I^2t (for Fusing), 8.3 ms	I^2t	2000		A ² sec
Average Gate Power Dissipation	$P_{G(AV)}$	2		Watts
Storage Temperature	T_{stg}	-40 to 150		°C
Operating Temperature	T_j	-40 to 125		°C
Mounting Torque ①		30		in.-lb.
Mounting Torque ①		3.4		N-m

① Consult recommended mounting procedures.

② Applies for zero or negative gate bias.

③ Per JEDEC RS-397, 5.2.2.1.

④ With recommended gate drive.

⑤ Higher di/dt ratings available, consult factory.

⑥ Per JEDEC standard RS-397, 5.2.2.8.



T-25-17

Powerex, Inc., Hillis Street, Youngwood, Pennsylvania 15697 (412) 925-7272

Powerex Europe, S.A., 428 Avenue G. Durand, BP107, 72003 Le Mans, France (43) 41.14.14

C148

Inverter Grade SCR

63 Amperes RMS/600-1200 Volts/30-40 μ sec

Electrical Characteristics

Characteristics	Symbol	Test Conditions	C148			Units
			Min.	Typ.	Max.	
Current—Conducting State Maximums						
Peak On-State Voltage	V_{TM}	$T_c = 25^\circ\text{C}$, $I_T = 500\text{A}$	—	—	4.0	Volts
Voltage—Blocking State Maximums						
Forward Leakage, Peak	I_{DRM}	$T_j = 125^\circ\text{C}$, $V_D = V_{DRM}$	—	7	12	mA
Reverse Leakage, Peak	I_{RRM}	$T_j = 125^\circ\text{C}$, $V_R = V_{RRM}$	—	7	12	mA
Typical Critical dv/dt exponential to V_{DRM} ②③	dv/dt	$T_j = 125^\circ\text{C}$, $V_D = V_{DRM}$	200	—	—	V/ μ sec
Thermal						
Maximum Thermal Resistance ① Junction to Case	$R_{th(j-c)}$		200	—	—	$^\circ\text{C}/\text{Watt}$
Gate—Maximum Parameters						
Gate Current to Trigger	I_{GT}	$T_c = 25^\circ\text{C}$, $V_D = 6\text{V}$, $R_L = 3\Omega$	—	—	150	mA
Gate Voltage to Trigger	V_{GT}	$T_c = 25^\circ\text{C}$, $V_D = 6\text{V}$, $R_L = 3\Omega$	—	—	3.0	Volts
Non-Triggering Gate Voltage	V_{GD}	$T_c = 125^\circ\text{C}$, $V_D = V_{DRM}$, $R_L = 1\text{k}\Omega$	0.25	—	—	Volts

① Consult recommended mounting procedures.

② Applies for zero or negative gate bias.

③ Per JEDEC RS-397, 5.2.2.1.

④ With recommended gate drive.

⑤ Higher dv/dt ratings available, consult factory.

⑥ Per JEDEC standard RS-397, 5.2.2.6.



T-25-17

Powerex, Inc., Hillis Street, Youngwood, Pennsylvania 15697 (412) 925-7272

Powerex Europe, S.A., 428 Avenue G. Durand, BP107, 72003 Le Mans, France (43) 41.14.14

C148

Inverter Grade SCR

63 Amperes RMS/600-1200 Volts/30-40 μ sec

Electrical Characteristics

Characteristics	Symbol	Test Conditions	C148-30			C148-40			Units
			Min.	Typ.	Max.	Min.	Typ.	Max.	
Switching Circuit									
Turn-Off Time	t_q	$T_c = +125^\circ\text{C}$, $I_{TM} = 150\text{A}$, $V_R = 50\text{V}/\text{min.}$, $di/dt = 5\text{A}/\mu\text{s}$, reapplied $dv/dt = 20\text{V}/\mu\text{s}$ linear Repetition Rate = 1 pps Gate Bias During Turn-Off Interval $V_D = 0\text{V}$, $R_L = 100\Omega$	—	—	30	—	—	40	μsec
Turn-Off Time	t_q	$T_c = +125^\circ\text{C}$, $I_{TM} = 150\text{A}$, $V_R = 50\text{V}/\text{min.}$, $di/dt = 5\text{A}/\mu\text{s}$, reapplied $dv/dt = 200\text{V}/\mu\text{s}$ linear Repetition Rate = 1 pps Gate Bias During Turn-Off Interval $V_D = 0\text{V}$, $R_L = 100\Omega$	—	38	†	—	48	†	μsec
Turn-Off Time (with Feedback Diode)	t_q	$T_c = +125^\circ\text{C}$, $I_{TM} = 150\text{A}$, $V_R = 1\text{V}$, $di/dt = 5\text{A}/\mu\text{s}$, Repetition Rate = 1 pps Gate Bias During Turn-Off Interval $V_D = 0\text{V}$, $R_L = 100\Omega$	—	45	—	—	55	—	μsec

†Consult factory for a specified maximum turn-off time.



Powerex, Inc., Hillis Street, Youngwood, Pennsylvania 15697 (412) 925-7272
 Powerex Europe, S.A., 428 Avenue G. Durand, BP107, 72003 Le Mans, France (43) 41.14.14

C148
 Inverter Grade SCR
 63 Amperes RMS/600-1200 Volts/30-40 μ sec

MAXIMUM ON-STATE CHARACTERISTICS

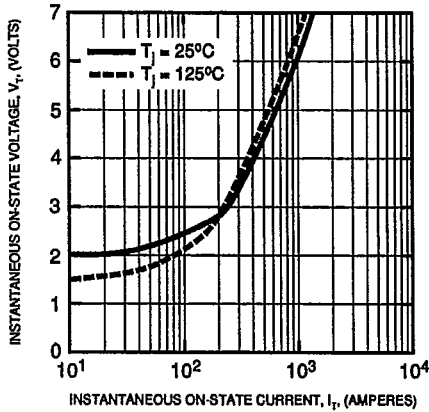

TRANSIENT THERMAL IMPEDANCE CHARACTERISTICS (JUNCTION TO CASE)

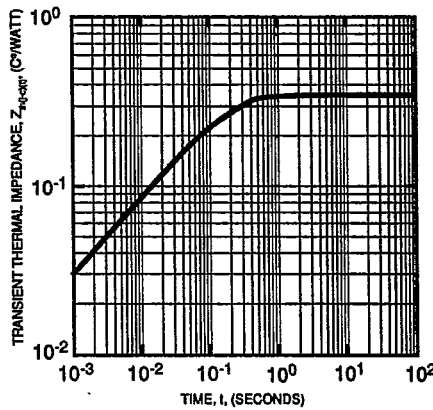

GATE CHARACTERISTICS AND POWER RATINGS

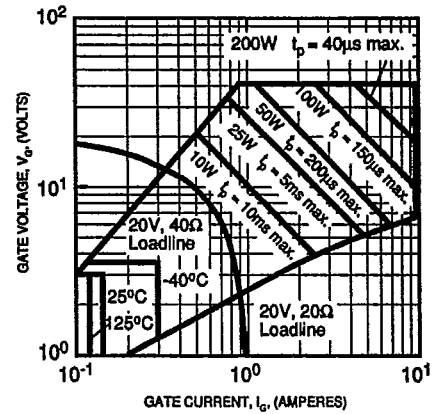

MAXIMUM ALLOWABLE NON-REPETITIVE SUB-CYCLE SURGE ON-STATE CURRENT AND I^2t RATINGS

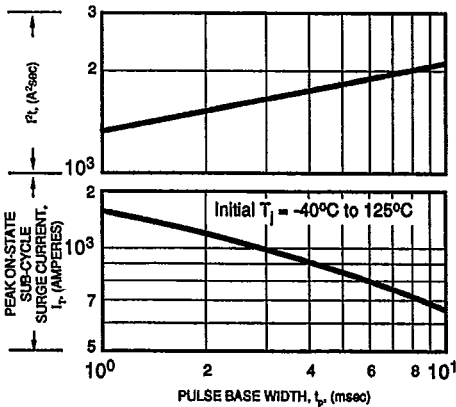

MAXIMUM ALLOWABLE PEAK FORWARD CURRENT

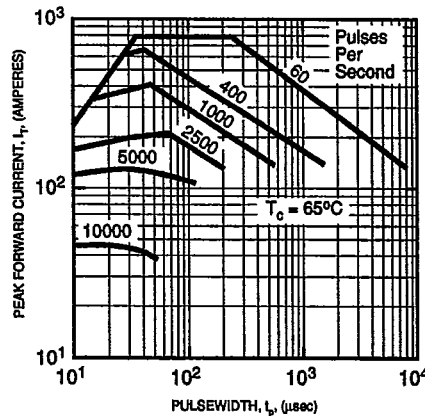

MAXIMUM ALLOWABLE PEAK FORWARD CURRENT

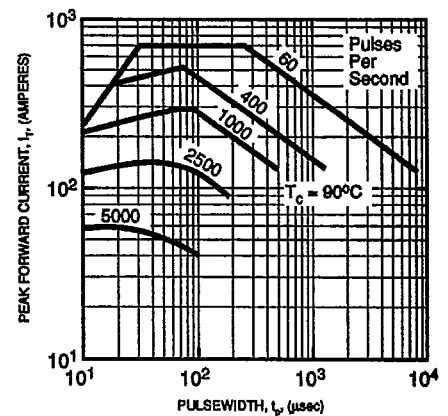

MAXIMUM ALLOWABLE PEAK ON-STATE CURRENT VS. di/dt

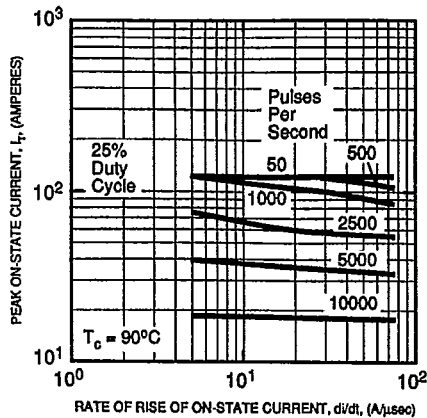

MAXIMUM ALLOWABLE PEAK ON-STATE CURRENT VS. di/dt

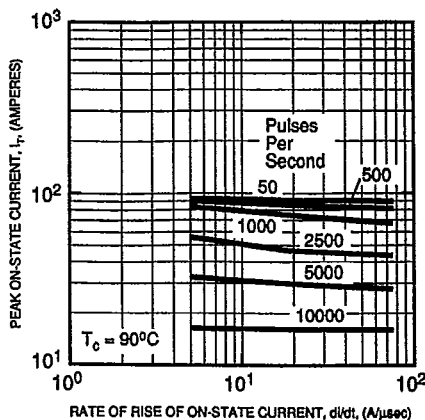

MAXIMUM ALLOWABLE PEAK ON-STATE CURRENT VS. di/dt

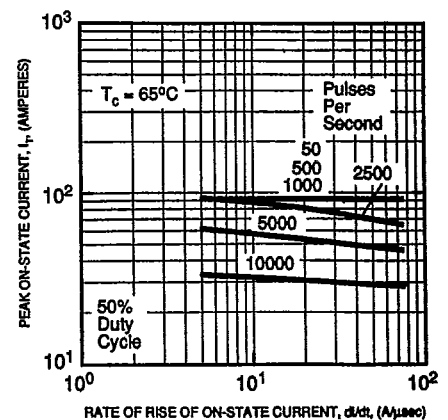



T-25-17

Powerex, Inc., Hillis Street, Youngwood, Pennsylvania 15697 (412) 925-7272
 Powerex Europe, S.A., 428 Avenue G. Durand, BP107, 72003 Le Mans, France (43) 41.14.14

C148
Inverter Grade SCR
 63 Amperes RMS/600-1200 Volts/30-40 μ sec

MAXIMUM ALLOWABLE PEAK ON-STATE CURRENT VS. dI/dt

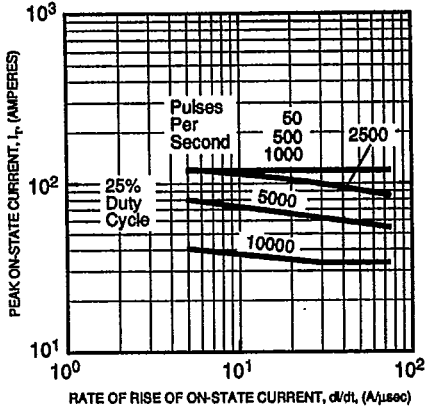

SINUSOIDAL PULSE ENERGY

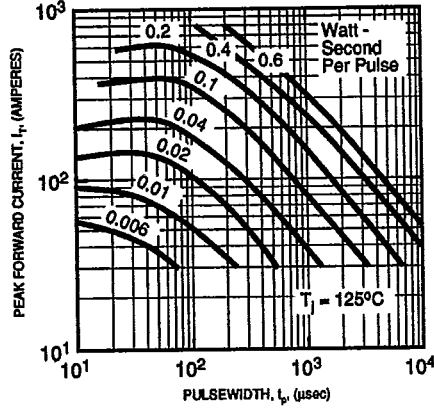

REVERSE RECOVERY CHARGE CHARACTERISTICS (SINUSOIDAL WAVEFORM)

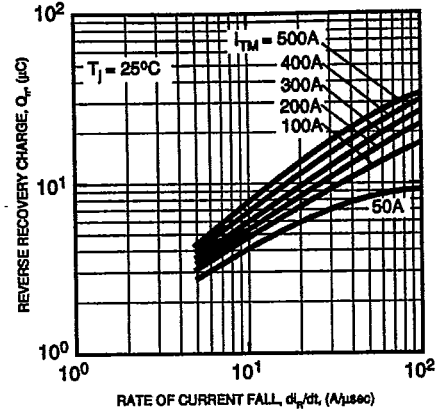

REVERSE RECOVERY CHARGE CHARACTERISTICS (SINUSOIDAL WAVEFORM)

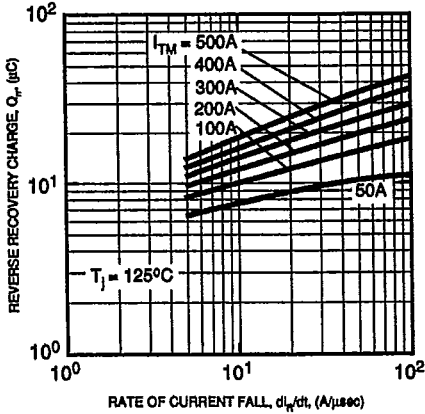

ENERGY PER PULSE VS. PEAK CURRENT AND PULSEWIDTH
 (T_J = 125°C; dI/dt = 100A/μsec)

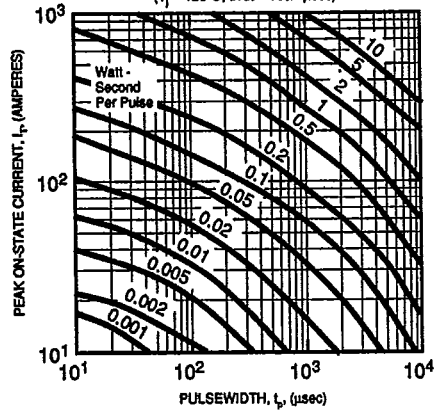

ENERGY PER PULSE VS. PEAK CURRENT AND PULSEWIDTH
 (T_J = 125°C; dI/dt = 25A/μsec)

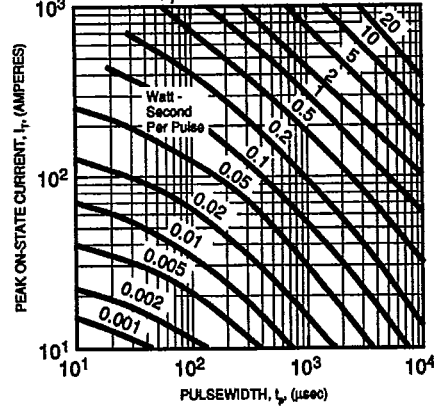

ENERGY PER PULSE VS. PEAK CURRENT AND PULSEWIDTH
 (T_J = 125°C; dI/dt = 5A/μsec)

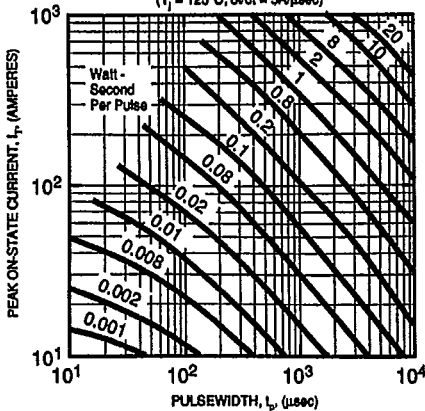



T-91-01

Powerex, Inc., Hillis Street, Youngwood, Pennsylvania 15697 (412) 925-7272
 Powerex Europe, S.A., 428 Avenue G. Durand, BP107, 72003 Le Mans, France (43) 41.14.14

Taping

STANDARD SPECIFICATIONS FOR TAPING OF MOLDED PACKAGE THYRISTORS AND TRIACS

TO-92 Package

Thyristor
CR02AM, CR03AM, CR04AM
Triac
BCR1AM

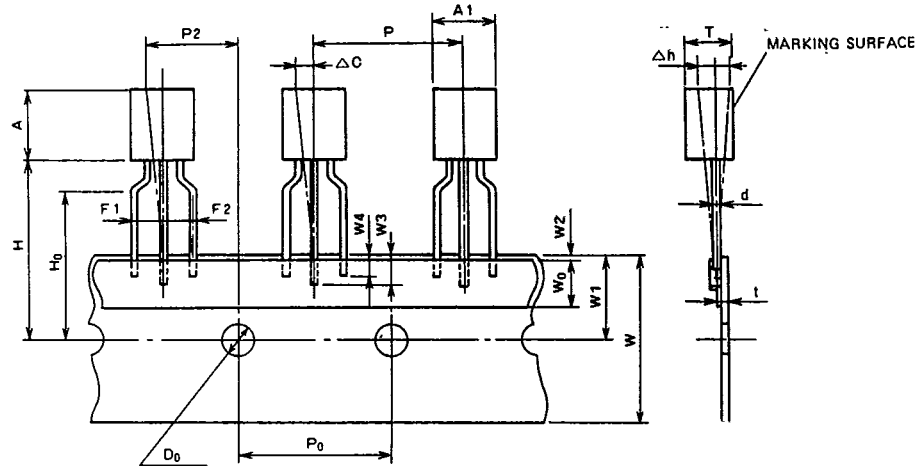

Taping dimensions

Description of symbol	Symbol	Dimensions (Unit:mm)	Remark
Product width	A1	5.0 MAX	
Product height	A	5.0 MAX	
Product thickness	T	3.7 MAX	
Lead wire diameter	d	0.6 MAX	
Sticker lead wire length (1)	W3	2.5 MIN	
Sticker lead wire length (2)	W4	2.0 MIN	
Pitch between products	P	12.7 ± 1.0	
Feed hole pitch	P ₀	12.7 ± 0.3	The cumulative pitch error is ± 1mm per 20 pitches.
Feed hole deviation (1)	P2	6.35 ± 1.3	
Distance between lead wires	F1, F2	2.5 ± 0.4	
Defective product (1)	Δh	0 ± 2.0	
Tape width	W	18.0 ± ^{1.0} / _{0.5}	
Sticker tape width	W ₀	6.0 ± 0.5	
Feed hole deviation (2)	W1	9.0 ± 0.5	
Sticker tape deviation	W2	0.5 MAX	
Position of product bottom surface	H	17.5 MIN	
Lynch height of lead wire	H ₀	16.0 ± 0.5	
Feed hole diameter	D ₀	4.0 ± 0.2	
Tape thickness	t	0.7 ± 0.2	
Defective product (2)	ΔC	0 ± 1.0	



Powerex, Inc., Hillis Street, Youngwood, Pennsylvania 15697 (412) 925-7272
 Powerex Europe, S.A., 428 Avenue G. Durand, BP107, 72003 Le Mans, France (43) 41.14.14

Powerex Semiconductor Data Book
 Taping

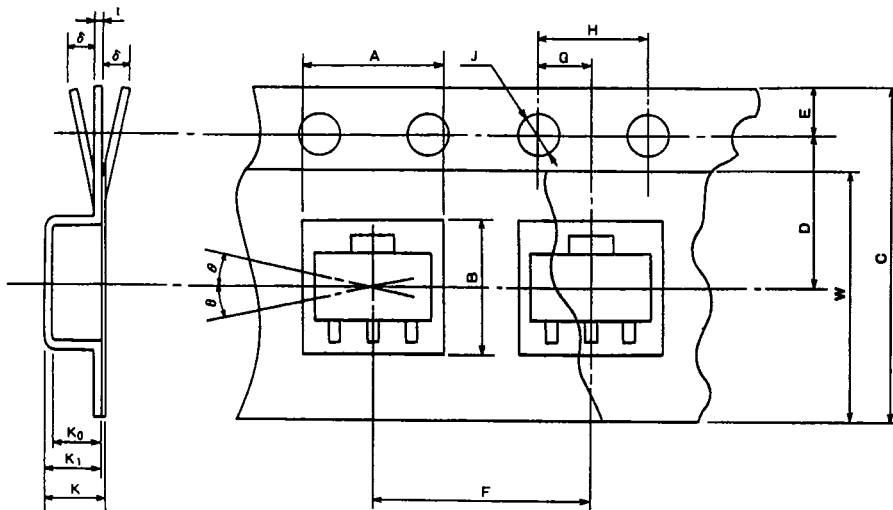

SOT-89 Package

Thyristor
 CR08AS

Taping dimensions

Description of symbol		Symbol	Dimensions/angles Unit:mm	Remark
Parts Insertion	Height	A	5.0 ± 0.1	Cross-section of the surface 0.5mm above the Inner bottom
	Width	B	4.6 ± 0.1	Cross-section of the surface 0.5mm above the inner bottom
Concave square hole	Depth	K_0	1.8 ± 0.1	Inner space
	Pitch	F	8.0 ± 0.1	Cumulative error +0.1/-0.3 MAX/10 pitches
Round feed hole	Diameter	J	$\phi 1.5 \pm 0.05$	
	Pitch	H	4.0 ± 0.1	Cumulative error +0.1/-0.3 MAX/10 pitches
	Position	E	1.5 ± 0.1	Distance between the tape edge and the hole center
Distance between center lines	Vertical	G	2.0 ± 0.5	Center line of concave square hole and round feed hole
	Horizontal	D	5.65 ± 0.05	Center line of concave square hole and round feed hole
Cover tape	Width	W	$9.5 + 0.3/-0$	Thickness: 0.1 MAX
Carrier tape	Width	C	12 ± 0.2	Warp ± 0.3 MAX
	Thickness	t	0.3 ± 0.05	
	Package hole depth	K_1	2.1 ± 0.1	
Device	Package dimensions	—	—	As shown in (e)
	Inclination	θ	30° MAX.	
Total Thickness		K	2.3 ± 0.1	Total thickness including cover and carrier tapes

This datasheet has been downloaded from:

www.DatasheetCatalog.com

Datasheets for electronic components.



LittleDiode supplies new, hard to find or obsolete electronic components and semiconductors all over the world.

With over two million different components listed you are sure to find the part you need.

Feel free to visit us today at our online store:

LittleDiode.com

Looking forward to providing you with the best possible service.