

# HIP3™ Variable Attenuator

## 1.70–2.00 GHz



AV102-12

### Features

- +50 dBm IP3 Typical
- Low Loss 1 dB Typical
- Attenuation 30 dB Typical
- Good VSWR <1.5:1 Typical
- Small SOIC-8 Package

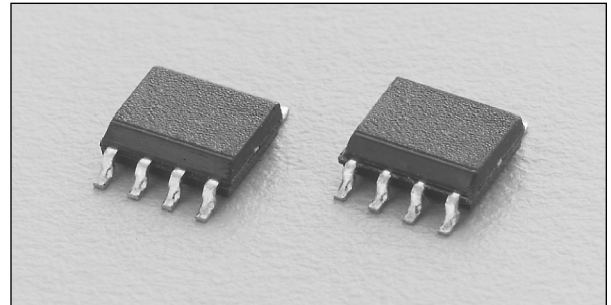

### Description

The AV102-12 is a current controlled variable attenuator from Alpha's series of HIP3™ components. It is designed to meet the wide dynamic range required in spread spectrum wireless base station applications. A monolithic quadrature hybrid is teamed with a silicon PIN diode pair in a plastic surface mount package reducing size and assuring consistency from part to part.

### Electrical Specifications at 25°C

Parameter	Min.	Typ.	Max.	Unit
Frequency	1.70		2.00	GHz
Insertion Loss (0 mA Control Current)		1	1.5	dB
Attenuation @ 3.0 mA Control Current (1850 MHz)	18.5		25.0	dB
VSWR All Ports		1.5	1.8	
Input 3rd Order Intercept	+47	+50		dBm
Group Delay		0.6	1.0	ns

### Operating Characteristics at 25°C (0, +5 V)

Parameter <sup>1</sup>	Condition	Frequency	Min.	Typ.	Max.	Unit
Switching Characteristics <sup>2</sup>	Rise, Fall (10/90% or 90/10% RF)				5	μs
	On, Off (50% CTL to 90/10% RF)				8	μs
	Video Feedthru (Peak)				2	mV
Maximum Input Power for <1 dB Attenuation Variation				+15		dBm

1. All measurements made in a 50 Ω system, unless otherwise specified.  
 2. 0–4 mA square wave total control current.

**Typical Performance Data**

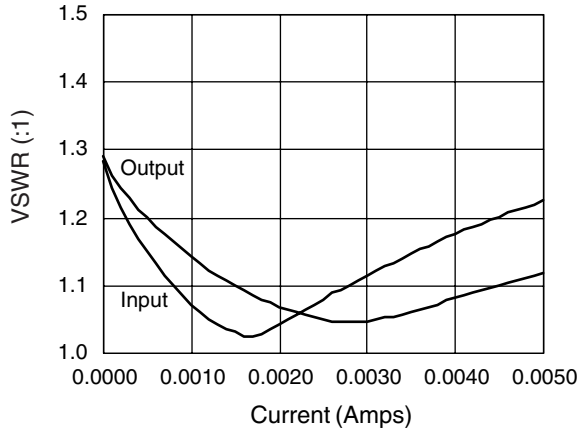

**Input/Output VSWR vs. Current @ 1700 MHz**

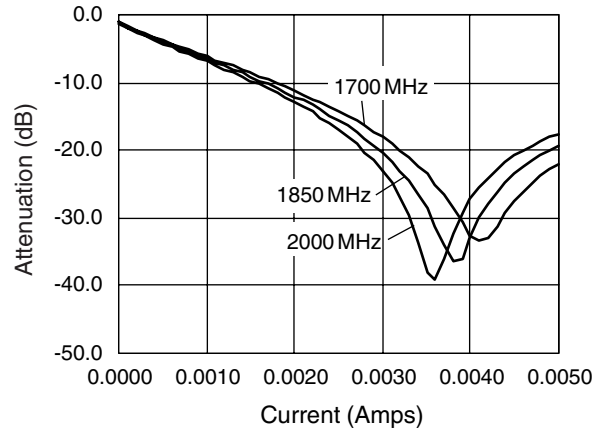

**Attenuation vs. Current**

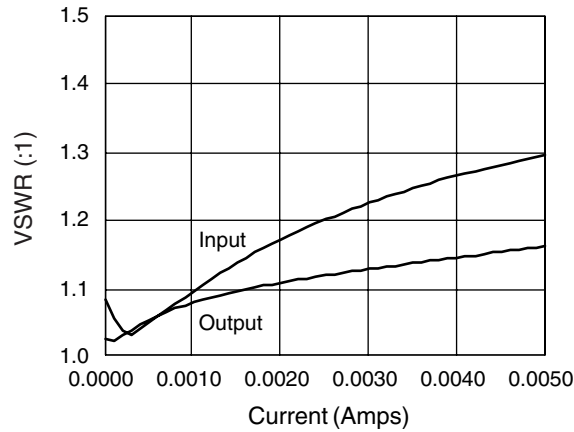

**Input/Output VSWR vs. Current @ 1850 MHz**

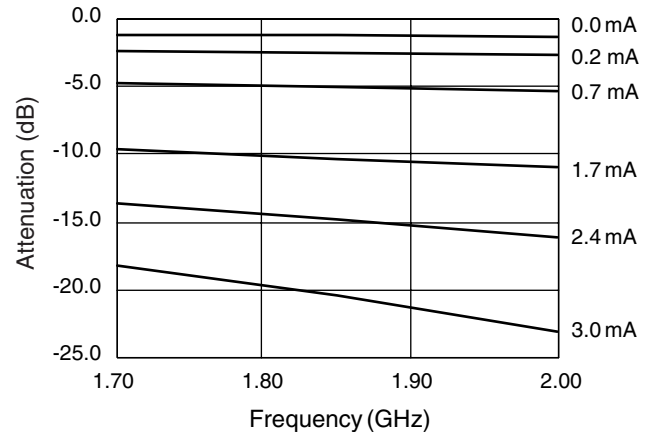

**Attenuation vs. Frequency**

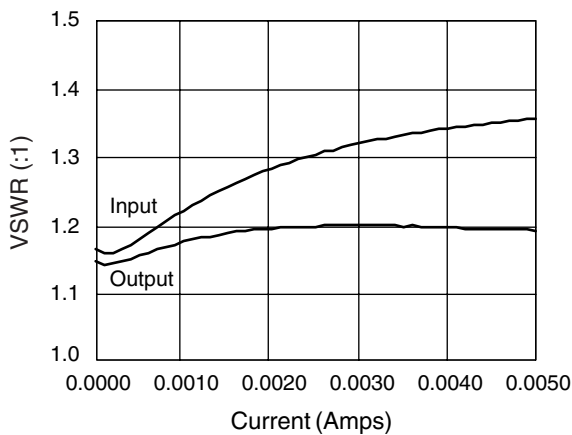

**Input/Output VSWR vs. Current @ 2000 MHz**

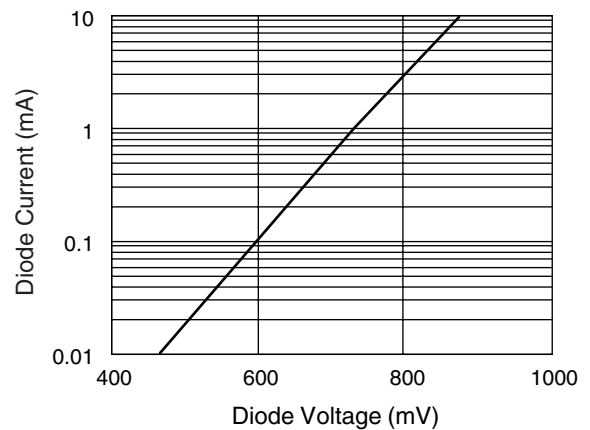

**Typical PIN Diode Current vs. Voltage**

**Pin Out**

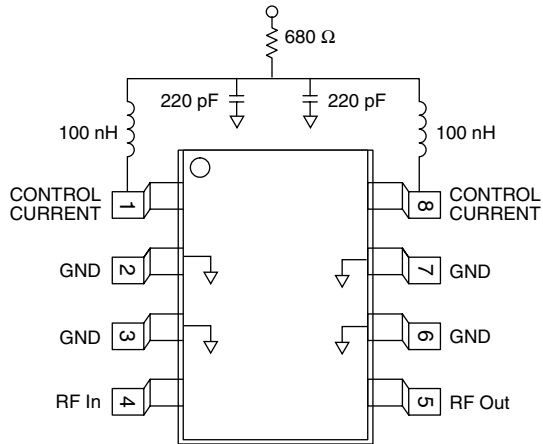

**Connection Diagram**

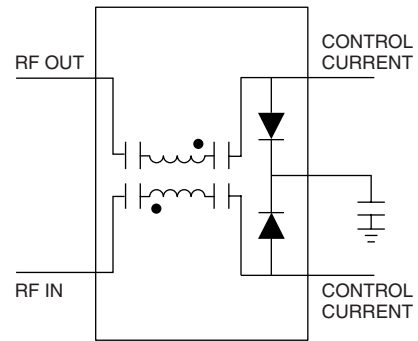

**Absolute Maximum Ratings**

Characteristic	Value
RF Input Power	.5 W CW, 4 W @ 12.5% Duty Cycle
Control Current	50 mA Each Diode
Operating Temperature	-40 to +85°C
Storage Temperature	-40 to +85°C
Maximum Reverse Diode Voltage	-10 V
Electrostatic Discharge	+125 V

Note: Operating this device above any of these parameters may cause irreversible damage.

**SOIC-8**

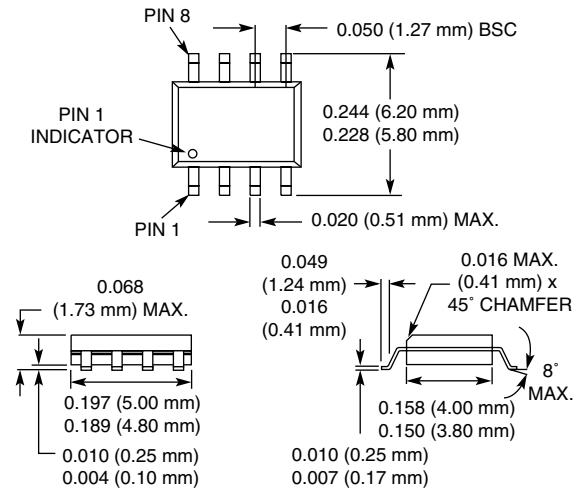

**Recommended Board Layout**

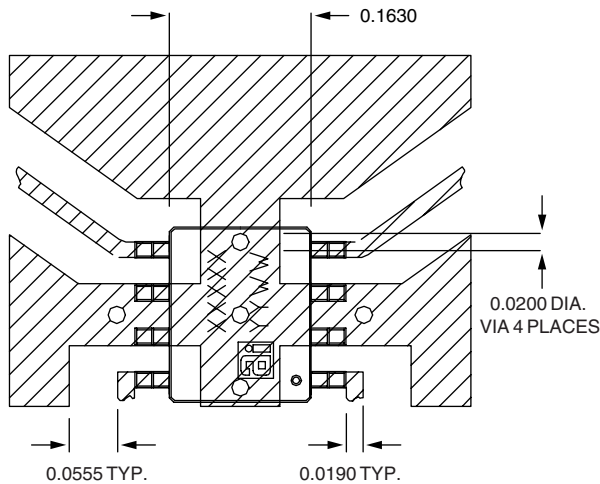

Material is 10 mil FR4.



LittleDiode supplies new, hard to find or obsolete electronic components and semiconductors all over the world.

With over two million different components listed you are sure to find the part you need.

Feel free to visit us today at our online store:

[LittleDiode.com](http://LittleDiode.com)

Looking forward to providing you with the best possible service.