

HIP3™ Variable Attenuator

2.10–2.30 GHz



AV113-12

Features

- Low Loss 1.4 dB Typical
- Attenuation 18 dB Typical
- Good VSWR <1.5:1 Typical
- Small SOIC-8 Package
- For IMT-2000 Applications

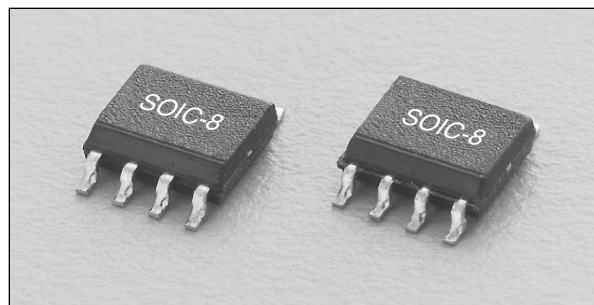

Description

The AV113-12 is a current controlled variable attenuator from Alpha's series of HIP3™ components. It is designed to meet the wide dynamic range required in IMT-2000 applications. A monolithic quadrature hybrid is teamed with a silicon PIN diode pair in a plastic surface mount package reducing size and assuring consistency from part to part.

Electrical Specifications at 25°C

Parameter	Min.	Typ.	Max.	Unit
Frequency	2.1		2.3	GHz
Insertion Loss (0 mA Control Current)		1.4	1.6	dB
Attenuation @ 1.0 mA Control Current	16.5	18		dB
VSWR All Ports		1.5		
Input 3rd Order Intercept Point		40		dBm
Group Delay		0.4	0.8	ns

Operating Characteristics at 25°C (0, +5 V)

Parameter ¹	Condition	Frequency	Min.	Typ.	Max.	Unit
Switching Characteristics ²	Rise, Fall (10/90% or 90/10% RF)				5	μs
	On, Off (50% CTL to 90/10% RF)				8	μs
	Video Feedthru (Peak)				2	mV
Maximum Input Power for <1 dB Attenuation Variation				+15		dBm

1. All measurements made in a 50 Ω system, unless otherwise specified.
 2. 0–4 mA square wave total control current.

Typical Performance Data

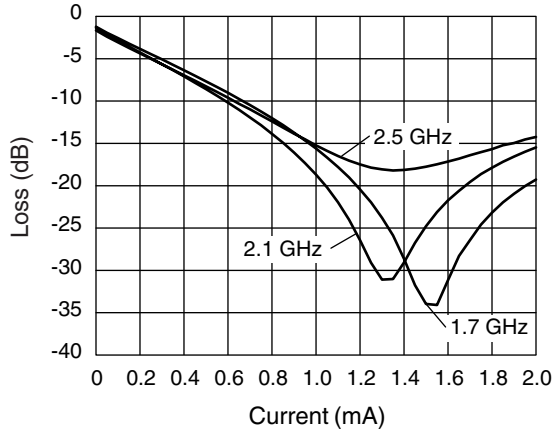

Attenuation vs. Control Current

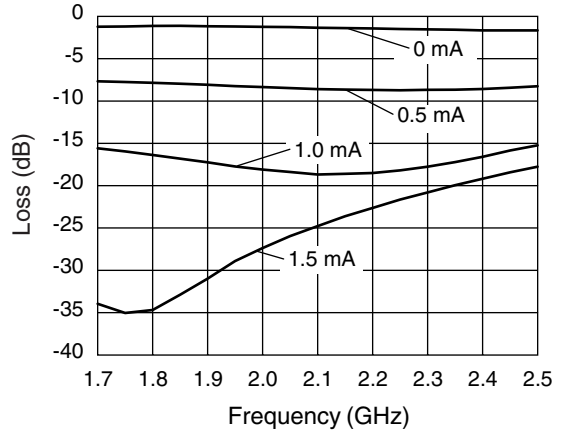

Attenuation vs. Frequency

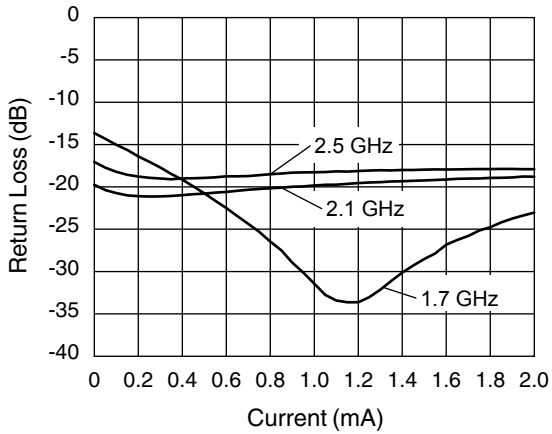

Input Return Loss vs. Current Control

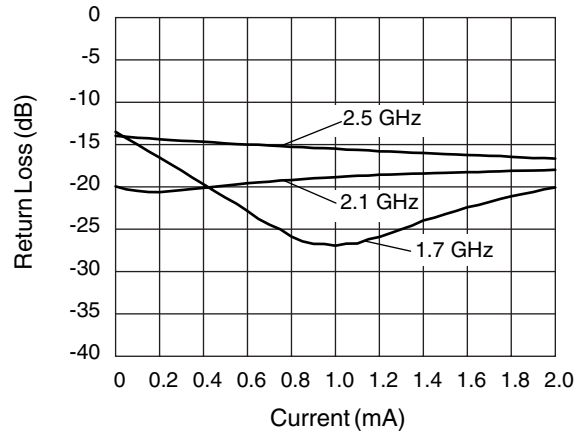

Output Return Loss vs. Current Control

Absolute Maximum Ratings

Characteristic	Value
RF Input Power	0.5 W CW, 4 W @ 12.5% Duty Cycle
Control Current	50 mA per Diode
Operating Temperature	-40 to +85°C
Storage Temperature	-40 to +85°C
Maximum Reverse Diode Voltage	-10 V
Electrostatic Discharge	+125 V

Note: Operating this device above any of these parameters may cause irreversible damage.

Pin Out

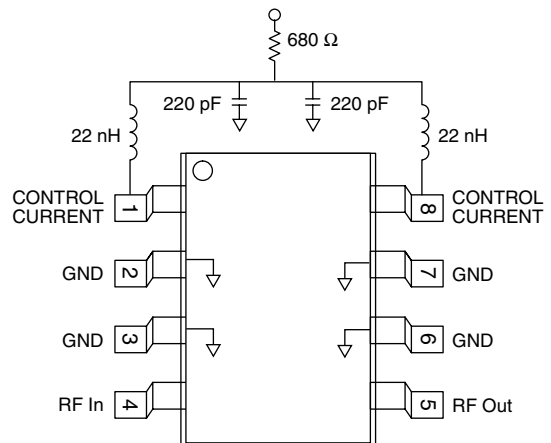

Recommended Board Layout

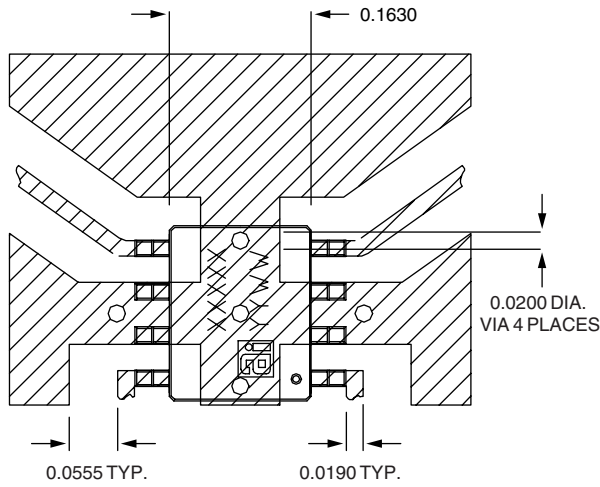

Material is 10 mil FR4.

Connection Diagram

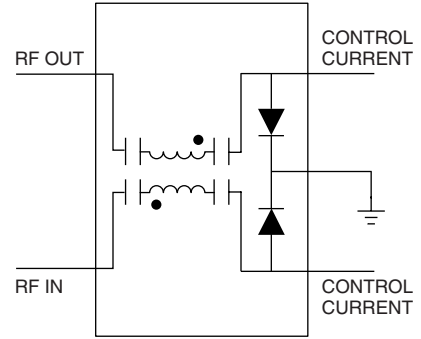

SOIC-8

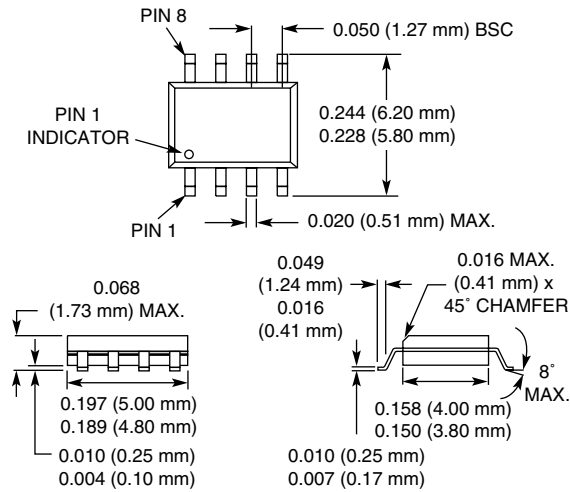



LittleDiode supplies new, hard to find or obsolete electronic components and semiconductors all over the world.

With over two million different components listed you are sure to find the part you need.

Feel free to visit us today at our online store:

LittleDiode.com

Looking forward to providing you with the best possible service.