

HIP3™ Variable Attenuator for DCS and PCS Base Stations



AV132-315

Features

- 23 dB Attenuation Range
- 1.5 dB Insertion Loss, 1.5 SWR
- 0–12 V Control Voltage
- 43 dBm IP3
- Small Footprint LGA Package
- Designed for DCS/PCS Base Station Applications

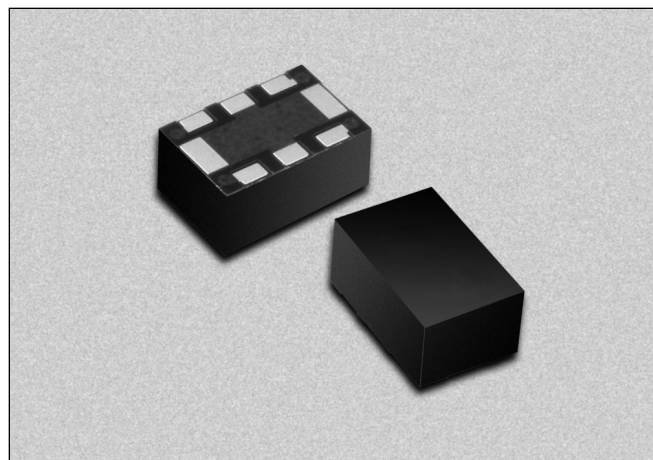

Description

The AV132-315 is a voltage controlled variable attenuator from Alpha's series of HIP3™ components. It is specifically designed and specified for use as a wide dynamic range low distortion attenuator for DCS and PCS base station applications centered at 1837.5 MHz and 1960 MHz. The AV132-315 employs a monolithic quadrature hybrid and a pair of silicon PIN diodes to achieve the specified low distortion performance. It operates from 0–12 V with 1.6 mA typical control current at maximum attenuation. The AV132-315 is packaged in a small outline LGA (Land Grid Array) surface mount package with the internal elements affixed to an organic BT substrate.

Electrical Specifications at 25°C

| Parameter | Condition | Min. | Typ. | Max. | Unit |
|---------------------------------|----------------------------|------|------|------|------|
| DCS Frequency Range (BW) | | 1805 | | 1870 | MHz |
| PCS Frequency Range (BW) | $F_O \pm 30.0$ MHz | 1930 | | 1990 | MHz |
| Control Voltage (C_V) Range | | 0 | | 12 | V |
| Insertion Loss in BW | $C_V = 0$ V | | | 1.5 | dB |
| Attenuation Range | At F_O , $C_V = 12$ V | 23 | | | dB |
| VSWR in BW | | | | 1.5 | |
| IP3 | 1900/1905 MHz, $C_V = 0$ V | 43 | | | dBm |
| IM3 | 8 dBm | | | -70 | dBc |

Typical Performance Data

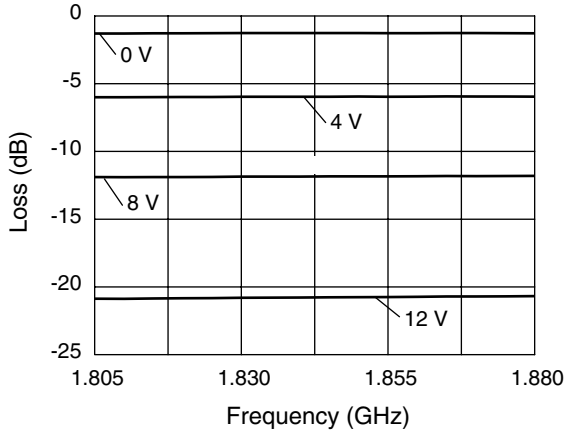

Insertion Loss vs. Frequency and Control Voltage — DCS Band

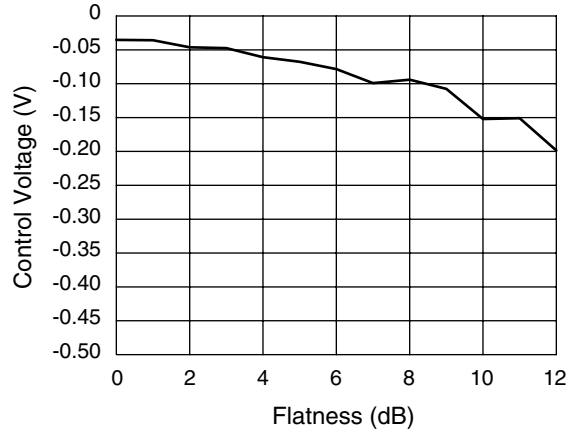

Insertion Loss Flatness vs. Control Voltage — DCS Band

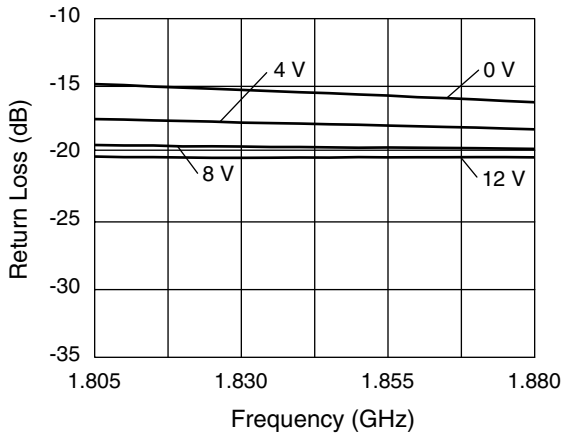

Input/Output Return Loss vs. Frequency and Control Voltage — DCS Band

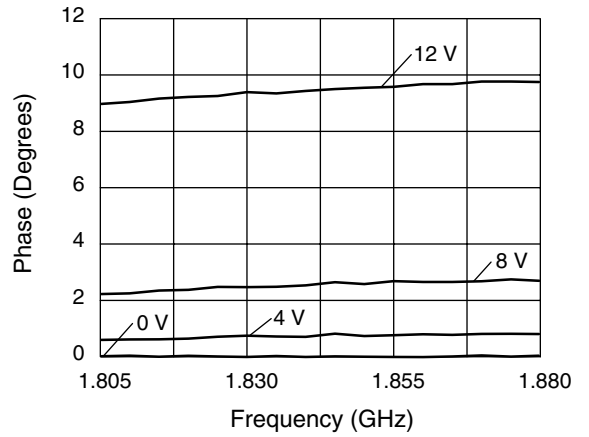

Phase vs. Frequency and Control Voltage — DCS Band

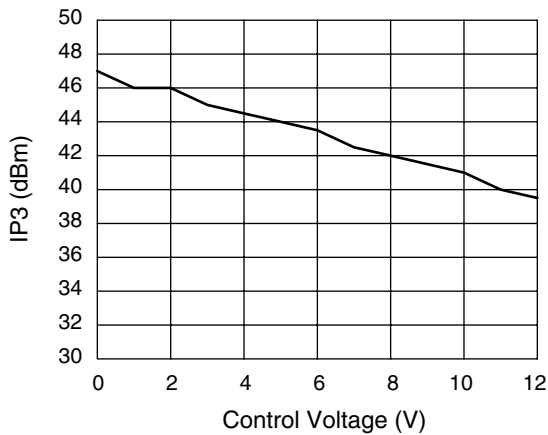

IP3 vs. Control Voltage

RF₁ = 1.900 GHz, RF₂ = 1.905 GHz @ 8 dBm

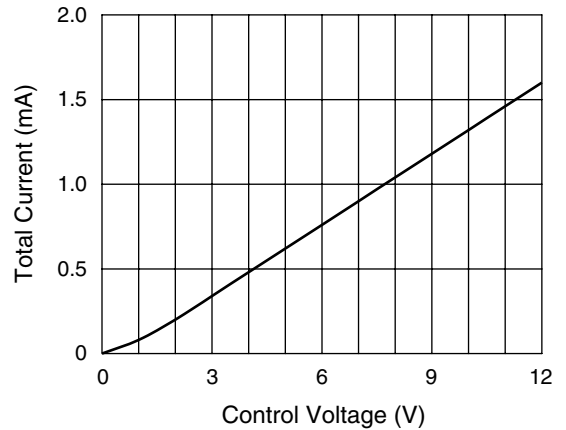

Total Current vs. Control Voltage

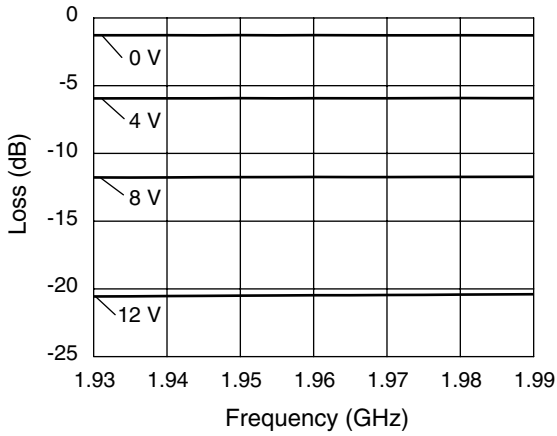

Insertion Loss vs. Frequency and Control Voltage — PCS Band

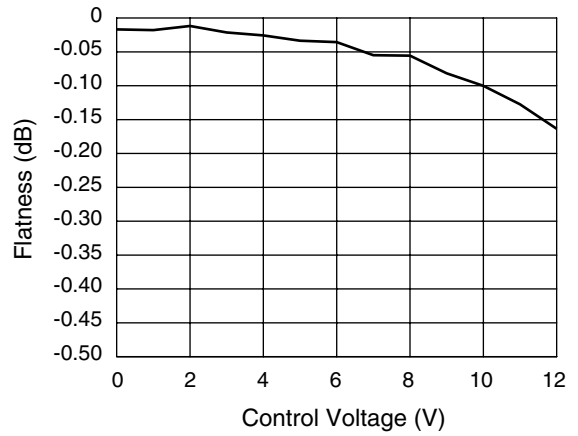

Insertion Loss Flatness vs. Control Voltage — PCS Band

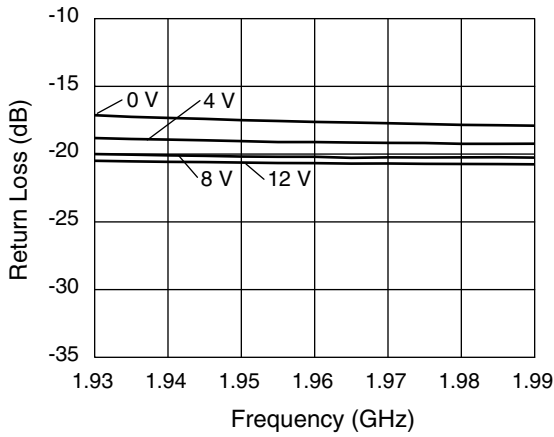

Input/Output Return Loss vs. Frequency and Control Voltage — PCS Band

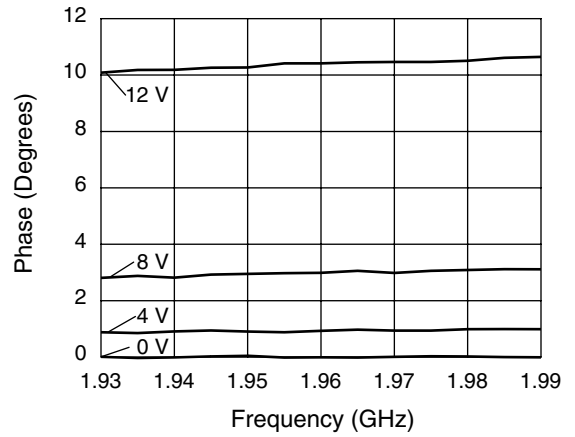

Phase vs. Frequency and Control Voltage — PCS Band

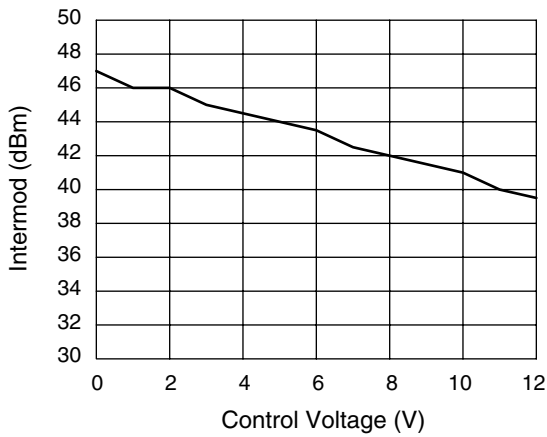

**3rd Order Intermod vs. Control Voltage
RF₁ = 1.900 GHz, RF₂ = 1.905 GHz @ 8 dBm**

Pin Out (Bottom View)

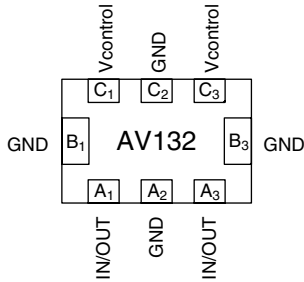

| Terminal No. | Terminal Name |
|----------------|---------------|
| A ₁ | IN/OUT |
| A ₂ | GND |
| A ₃ | IN/OUT |
| B ₁ | GND |
| B ₃ | GND |
| C ₁ | Vcontrol |
| C ₂ | GND |
| C ₃ | Vcontrol |

Absolute Maximum Ratings

| Characteristic | Value |
|-------------------------------|----------------------------------|
| RF Input Power | 0.5 W CW, 4 W @ 12.5% Duty Cycle |
| Control Voltage | 15 V |
| Control Current | 50 mA Each Diode |
| Operating Temperature | -40 to +85°C |
| Storage Temperature | -40 to +85°C |
| Maximum Reverse Diode Voltage | -10 V |
| Electrostatic Discharge | +125 V |

Note: Operating this device above any of these parameters may cause irreversible damage.

Connection Diagram

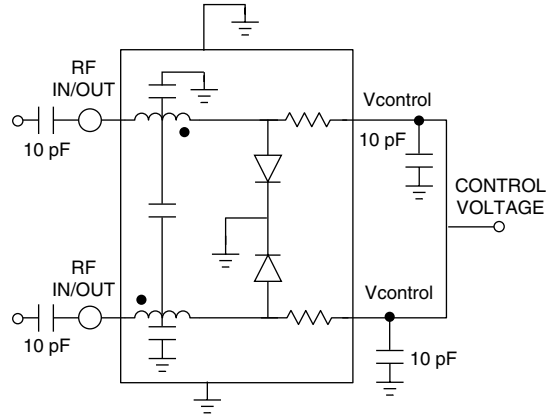

-315

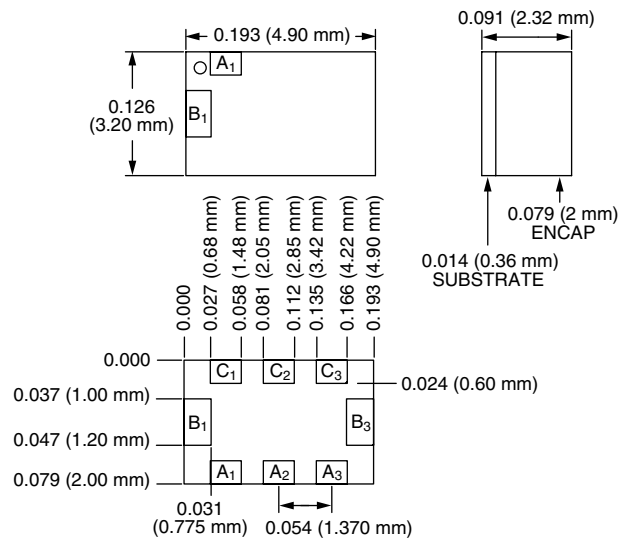



LittleDiode supplies new, hard to find or obsolete electronic components and semiconductors all over the world.

With over two million different components listed you are sure to find the part you need.

Feel free to visit us today at our online store:

LittleDiode.com

Looking forward to providing you with the best possible service.