

Dimensions (mm)

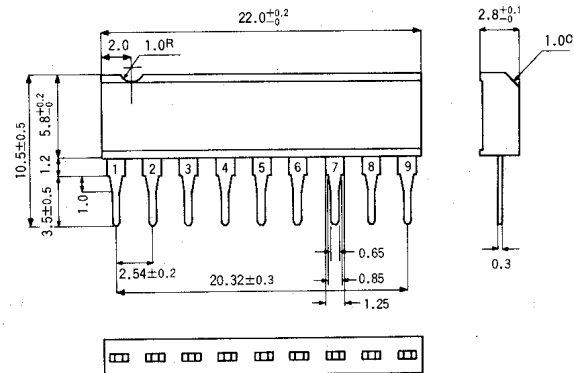

Fig. 1

The BA337 is a monolithic integrated circuit consisting of an auto-reverse controller for use in equipment such as car stereo cassette decks. It detects the reel rotation signal and, after a specified delay time, has a function which outputs a tape reversal pulse as well as one which allows either direct manual reversing or reversing using a reversal pulse during reel rotating operations. All of these functions are housed in a compact 9-pin SIL package. A built-in input amplifier is used, enabling the accommodation of the output levels associated with Hall devices or magnetic pickups in generating the reel rotation signal.

Block Diagram

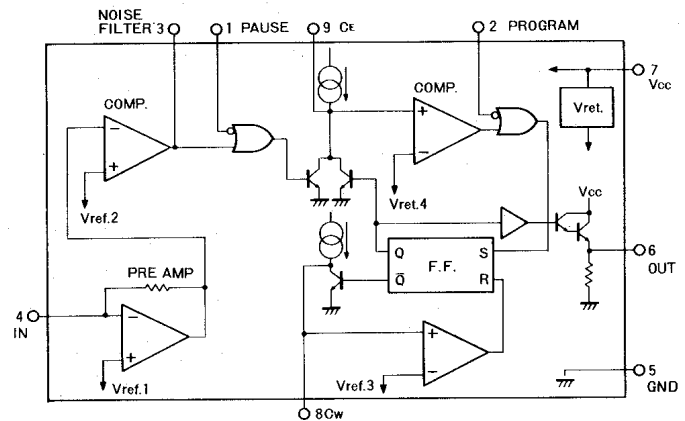

Fig. 2

Features

1. A built-in input amplifier is used, allowing control of the output levels to be made from Hall devices or magnetic pickups.
2. The END detection time and output pulse width are adjustable by means of an externally connected capacitance.
3. Wide supply voltage range
4. Low power consumption

Applications

1. Car stereos
2. Radio cassette tape recorders

Absolute Maximum Ratings (T_a = 25°C)

| Parameter | Symbol | Limits | Unit |
|-----------------------|------------------|----------|------|
| Supply voltage | V _{CC} | 18 | V |
| Power dissipation | P _d | 700* | mW |
| Operating temperature | T _{opr} | -20~+75 | °C |
| Storage temperature | T _{stg} | -55~+125 | °C |
| Output current | I _o | 200** | mA |

* Derating is done at 7mW/°C for operation above T_a = 25°C.

**30% duty cycle 0.2s on-state

Electrical Characteristics (Unless otherwise noted, T_a = 25°C, V_{CC} = 13.2V)

| Parameter | Symbol | Min | Typ | Max | Unit | Conditions | Test circuit |
|------------------------------------|------------------|-----|-----|-----|-------------------|---|--------------|
| Supply voltage | V _{CC} | 4.2 | — | 16 | VDC | | Fig. 7 |
| Supply current | I _{CC} | — | 1.5 | 2.5 | mA | V _{IN} =0 PAUSE: GND PROGRAM: OPEN | Fig. 7 |
| Input discrimination level | V _{IN} | 35 | 60 | 100 | mV _{p-p} | f = 1kHz SINE WAVE | Fig. 7 |
| End detection time | T _E | — | 75 | — | ms | C _E = 1μF | Fig. 7 |
| Output pulse width | T _W | — | 25 | — | ms | C _W = 1μF | Fig. 7 |
| High-level output voltage | V _{OH} | 8 | 10 | — | V | I _{OUT} = 100mA | Fig. 7 |
| Output leakage current | I _L | — | — | 10 | μA | | Fig. 7 |
| Pause terminal threshold voltage | V _{TH1} | 0.7 | 1.2 | 1.8 | V | | Fig. 7 |
| Program terminal threshold voltage | V _{TH2} | 0.7 | 1.2 | 1.8 | V | | Fig. 7 |