

High-definition sound processor

BA3880AS / BA3880AFS

The BA3880AS and BA3880AFS are sound processor ICs that perform phase and harmonic compensation on audio signals to accurately reproduce the "rise" section of audio signals that determines the characteristics of the sound, and thus reproduce the original recording as naturally as possible.

●Applications

Component stereo systems, radio cassette players, car stereo systems, televisions, VCRs, and active speakers.

●Features

- 1) Correct distortion in the rising section of audio signals that results from miss-matched speakers and amplifiers, and reproduces the original sound faithfully.
- 2) To allow application with all types of speakers and sources, the clarity can be adjusted using DC control.
- 3) DC control provided for selection of either processor mode or bypass mode.
- 4) Bass boost fixed internally to 4dB.

●Block diagram

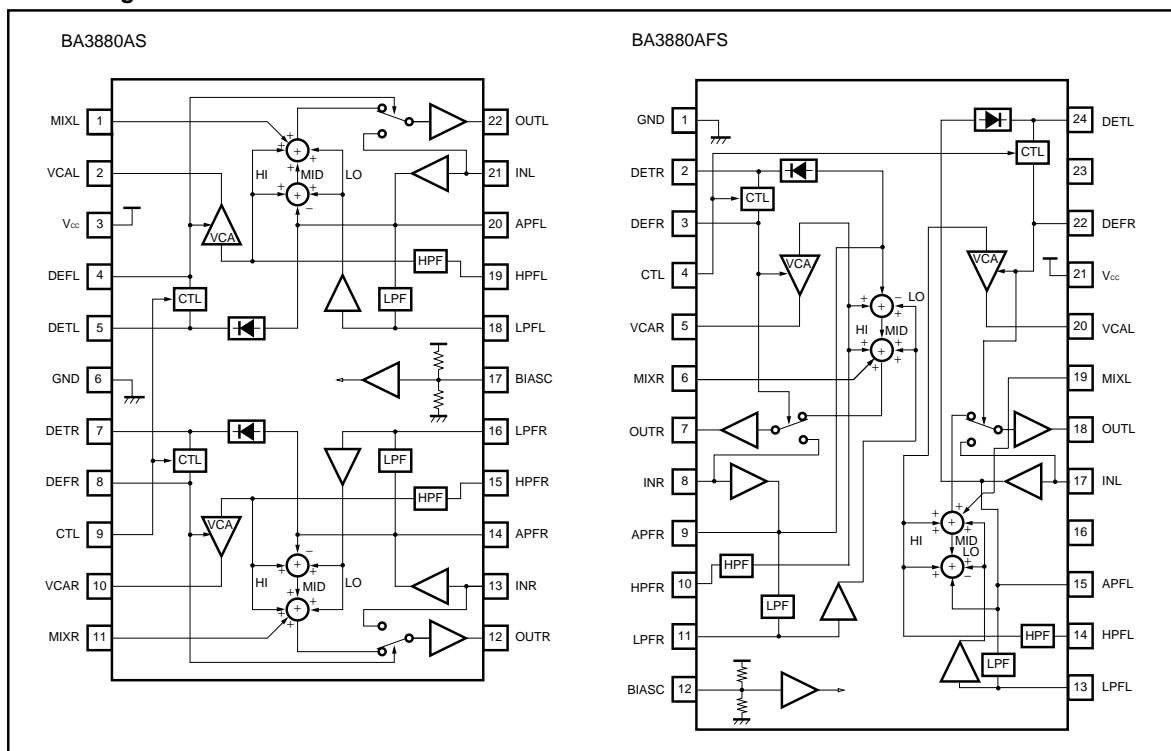

Audio ICs

●Absolute maximum ratings (Ta = 25°C)

Parameter	Symbol	Limits	Unit
Power supply voltage	V _{CC}	11	V
Power dissipation	P _d	1000 *	mW
Operating temperature	T _{opr}	-40~+85	°C
Storage temperature	T _{stg}	-55~+125	°C

* Reduced by 10mW for each increase in Ta of 1°C over 25°C.

●Recommended operating conditions

Parameter	Symbol	Limits	Unit
Power supply voltage	V _{CC}	5.4~10.8	V

●Electrical characteristics

(unless otherwise noted, Ta = 25°C, V_{CC} = 9V, f_{IN} = 1kHz, V_{IN} = 200mVrms, R_g = 600Ω, R_L = 100kΩ and V_{CTL} = 4.5V)

Parameter	Symbol	Min.	Typ.	Max.	Unit	Conditions
Circuit current	I _{CC}	3.9	5.9	11.8	mA	V _{IN} = 0Vrms
Voltage gain 1	G _{V1}	-2.0	0	2.0	dB	V _{CTL} = 9V
Voltage gain 2	G _{V2}	-2.5	-0.5	1.5	dB	
Voltage gain 3	G _{V3}	-1.0	1.0	4.0	dB	f _{IN} = 10kHz
Voltage gain 4	G _{V4}	9.0	11.0	13.0	dB	f _{IN} = 10kHz, V _{CTL} = 0V
Voltage gain 5	G _{V5}	-	4.0	-	dB	f _{IN} = 50Hz
Channel balance	CB	-2.0	0	2.0	dB	f _{IN} = 10kHz, V _{CTL} = 0V
Maximum output voltage	V _{OM}	2.0	2.3	-	Vrms	THD = 1%
Output noise voltage 1	V _{NO1}	-	2	10	μVrms	R _g = 0Ω, DIN AUDIO, V _{CTL} = 9V
Output noise voltage 2	V _{NO2}	-	16	70	μVrms	R _g = 0Ω, DIN AUDIO
Total harmonic distortion 1	THD ₁	-	0.005	0.05	%	400Hz~30kHz BPF, V _{CTL} = 9V
Total harmonic distortion 2	THD ₂	-	0.04	0.4	%	400Hz~30kHz BPF
Channel separation	CS	-	-67	-60	dB	V _{IN} = 1Vrms
Ripple rejection ratio	RR	60	68	-	dB	R _g = 0Ω, f _R = 100Hz, V _R = 100mVrms

*Note : When V_{CTL} = 9V, the IC is in bypass mode (through operations).

When V_{CTL} = 4.5V, the IC is in processor mode (enhance operations) with minimum definition level.

When V_{CTL} = 0V, the IC is in processor mode (enhance operations) with maximum definition level.

● Measurement circuit

BA3880AS

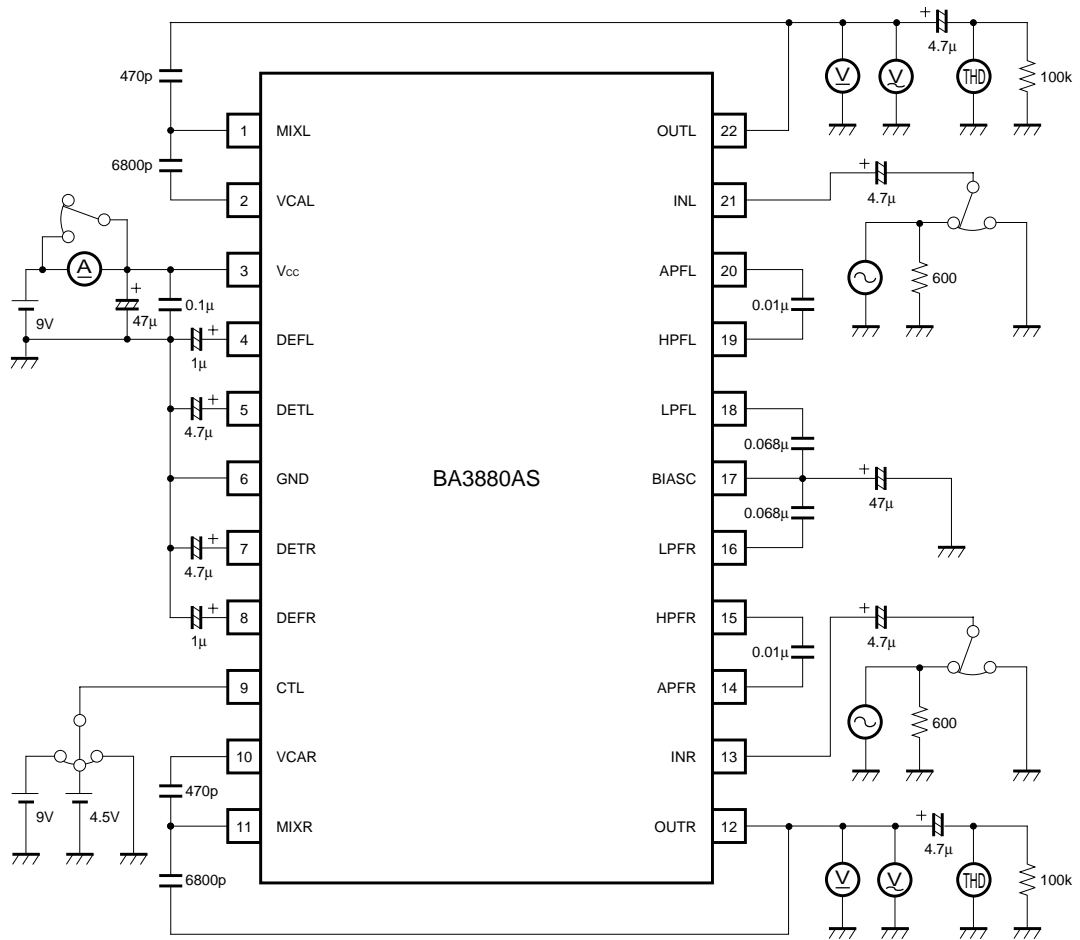

Fig.1

(Units) R : Ω
C : F

BA3880AFS

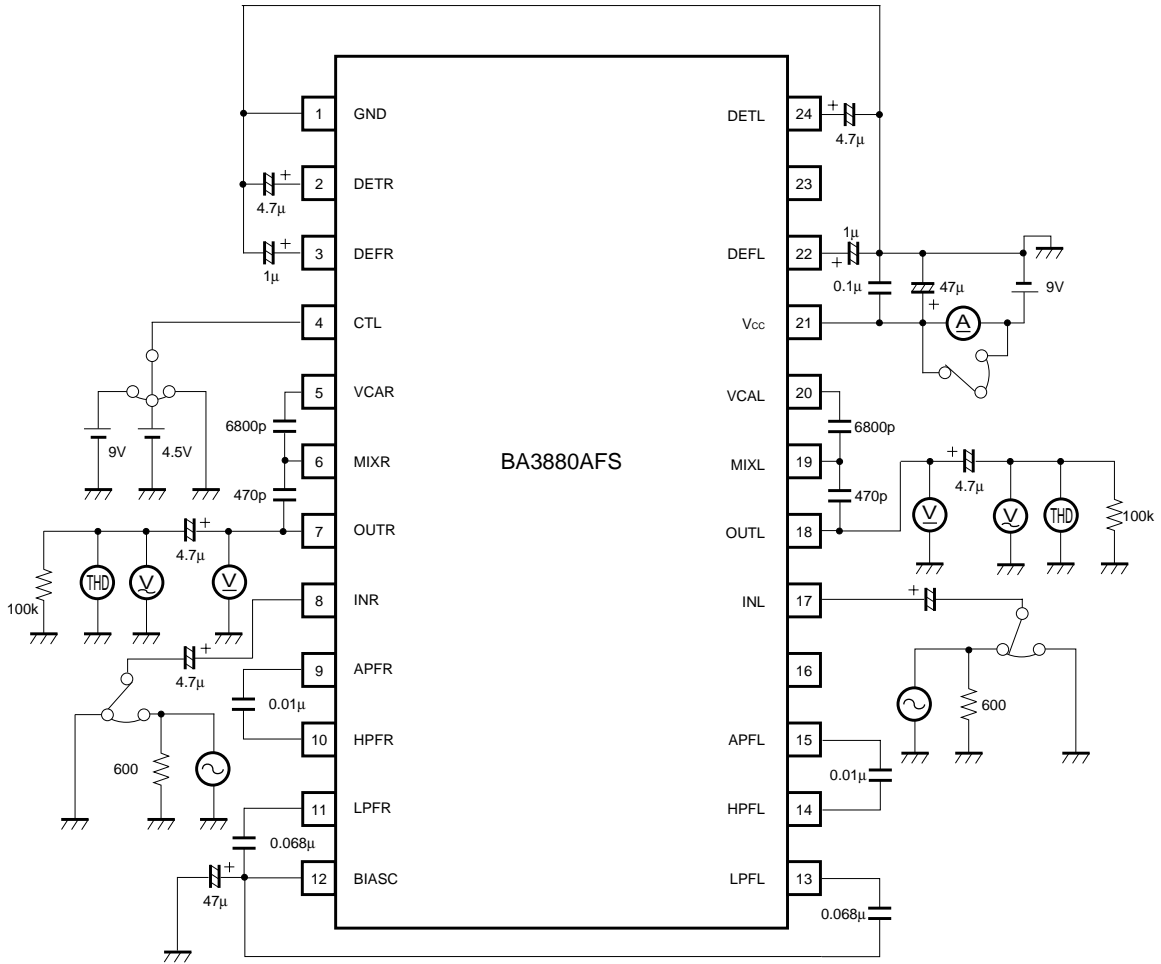

Fig.2

(Units) R : Ω
C : F

Audio ICs

●Circuit operation

The BA3880AS and BA3880AFS high-definition sound processor system ICs treat the amplifiers and speakers as a total audio systems, and perform signal processing at the amplifier input stage to accurately reproduce the rise sections of audio signals that determine the characteristics of sound, and ensure that the replayed audio is as close to the original sound and as natural sounding as possible.

Problems relating to playback of sound on audio systems.

With naturally-generated sound, high-frequency harmonic components generally occur first, followed by the fundamental frequency components. This also applies to the attack section of the sound that characterizes many musical instruments. It is the amplitude component that gives form to the frequency component and envelope at the rising point of sound, and this expresses the characteristics of the sound. Therefore, when replaying audio on audio playback systems, it is extremely important that the rise section of the signal be expressed accurately with respect to the original sound.

However, there is inevitable mismatching between the speakers and amplifiers in current audio systems. Solid-state power amplifiers use negative feedback techniques and operate off a fixed voltage supply, but as speakers are a current element, mismatching in the system inevitably occurs. In addition, the speaker impedance characteristics are strongly influenced by the electrical reactance of the voice coil, and the mechanical reactance of the cone assembly. As a result of this, distortion is generated in the rising sections of audio signals, causing phase shift in the reproduced sound. In addition, impedance increases in the treble region which reduces the speaker amplitude and reduces the harmonic component, and as a result there is a tendency to masking of large mid-frequency signal components that follow, and this makes it difficult to reproduce the rising sections of the sound.

●Operating principle

To solve the problems described above, the BA3880AS and BA3880AFS perform the audio signal processing described below.

Phase shift compensation

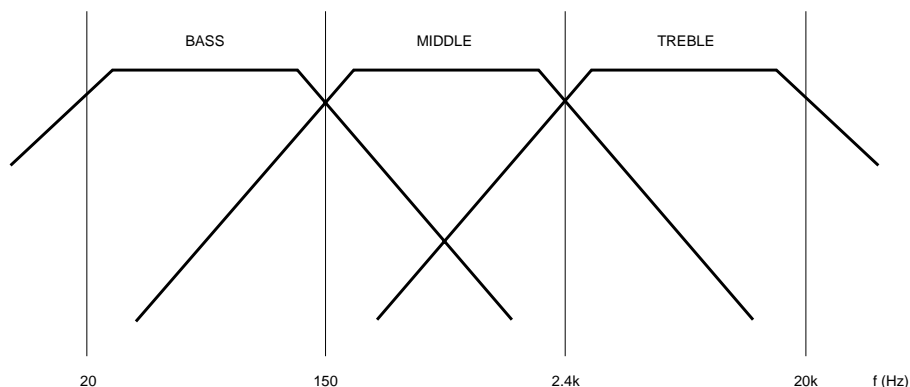

The input signal is separated into three regions: bass (20Hz to 150Hz), middle (150Hz to 2.4kHz) and treble (2.4kHz to 20kHz). These regions are then joined again with the middle and treble regions phase shifted -180° and -360° respectively with respect to the bass signal. This phase shift adjusts the delay time characteristic for each band and minimizes the distortion of the rising section of the audio signal.

Amplitude compensation (harmonic compensation)

To maintain appropriate auditory balance for the treble region that is made up of harmonic components, a high-speed detector and high-performance VCA circuit are used for amplitude control of the treble component. The amount of compensation is determined from a calculation performed based on the DC level input to the CTL pin, and the DC level detected from the input signal. The internal control signal obtained from this calculation compensates the amplitude of the treble component input to the VCA. This amplitude compensation recovers the harmonic component, and improves the reproduction clarity (definition level) of instruments and vocals.

Audio ICs

Bass boost

To maintain good balance with the dynamically changing treble component, the bass component is boosted. The bass boost is fixed at 4dB (typ.) internally, and cannot be adjusted.

Mode switch

The DC voltage on the CTL pin can be used to switch the IC between processing mode and bypass mode. When processing mode is selected, the audio signal is enhanced using the compensation circuits described above before being output. When bypass mode is selected, the signal bypasses all of the compensation circuits, and only passes through a buffer amplifier before output.

External components

The frequency characteristic in processing mode with maximum definition level is given below.

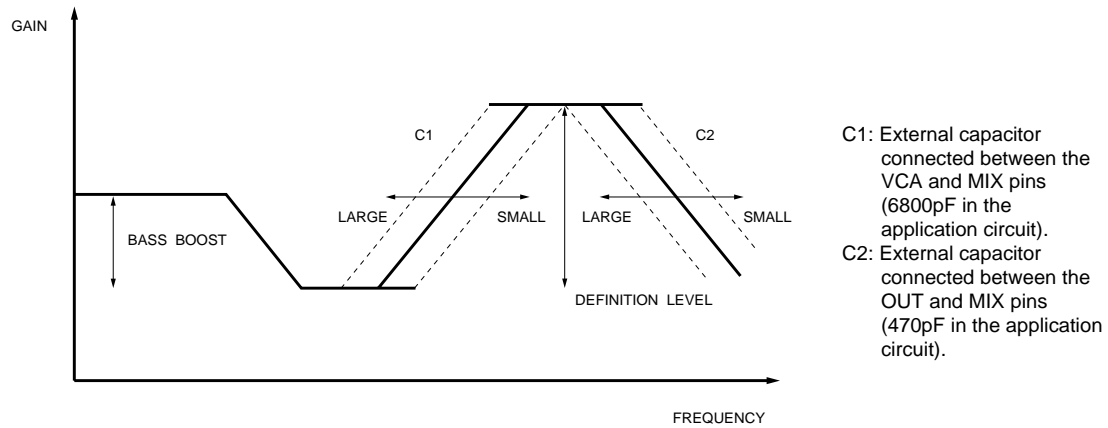

As indicated in the diagram, capacitors C1 and C2 determine the treble component cutoff frequency. By varying the values of these components, the frequency characteristic can be changed as indicated by the dotted line in the diagram. This varies the balance of the harmonic component, and is an important factor in determining the tone quality.

Control table

Item	Threshold level	Mode setting	Definition level
V _{CTL}	V _{CC}	Recommended setting range for bypass mode 0.75 × V _{CC}	Min. (1dB Typ.) Max. (11dB Typ.)
	0.64 × V _{CC}		
	0.57 × V _{CC}	Recommended setting range for processor mode 0.5 × V _{CC}	
0V (GND)			

Audio ICs

●Application example
BA3880AS

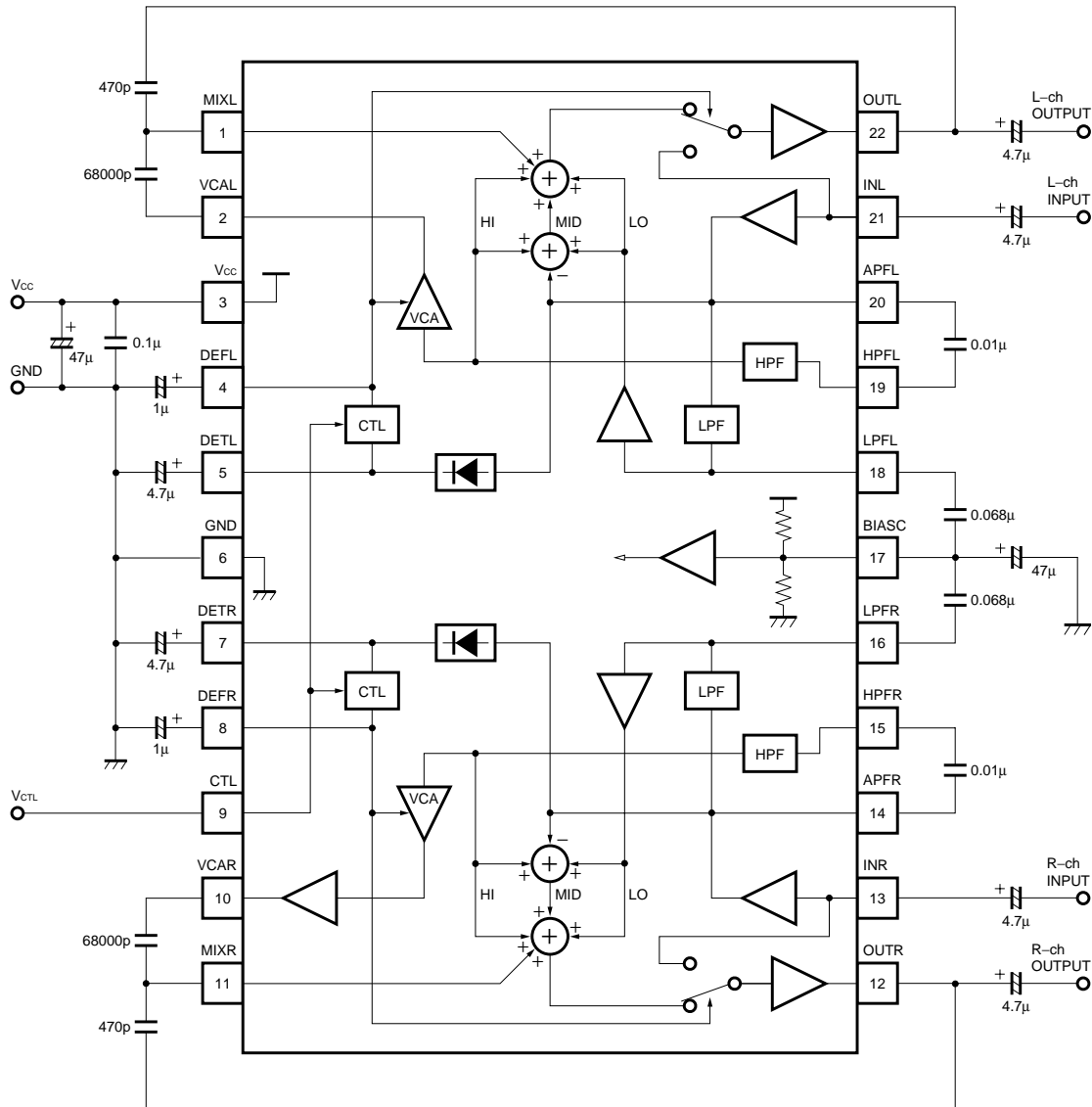

Fig.3

(Units) R : Ω
C : F

BA3880AFS

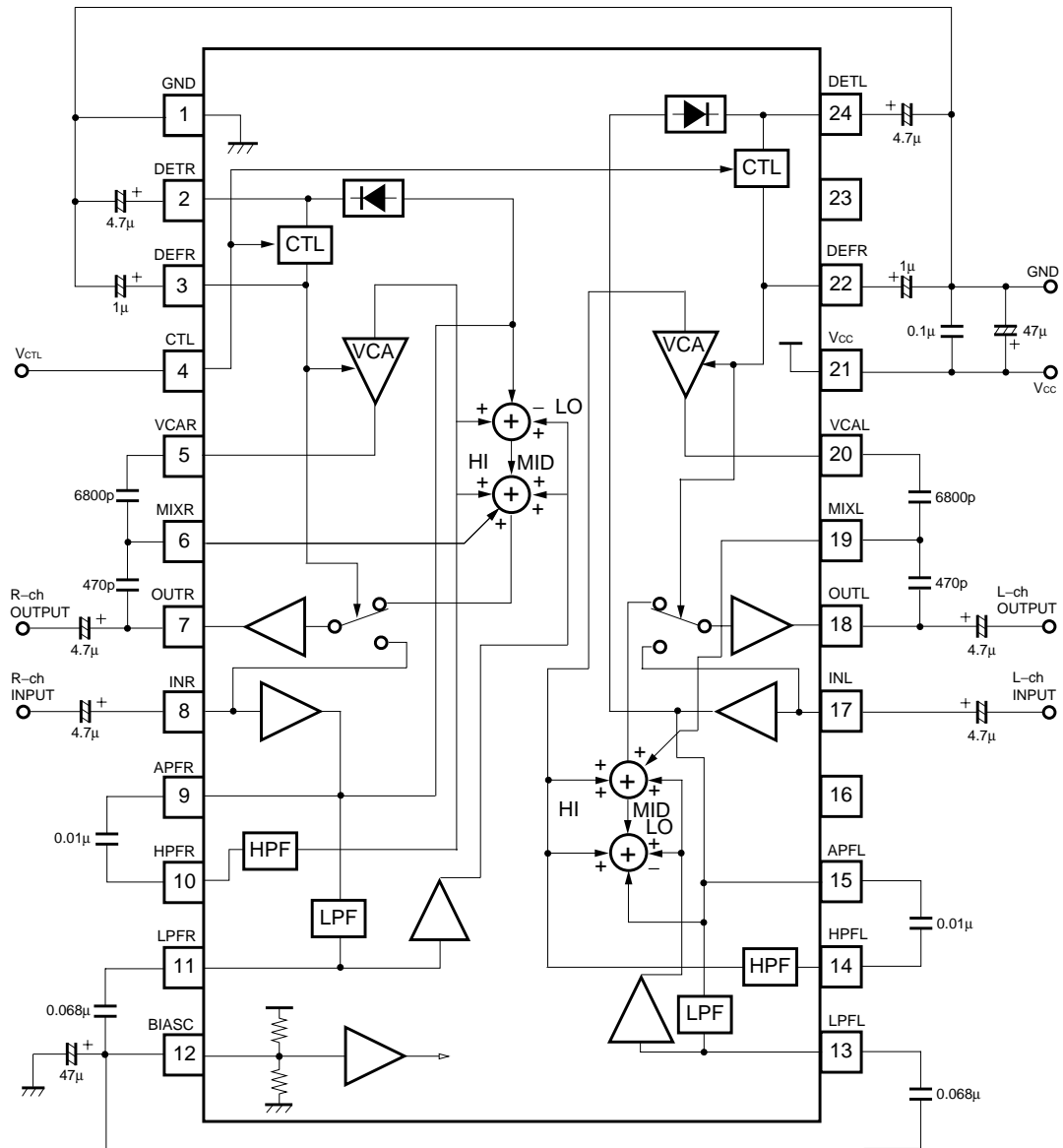

Fig.4

(Units) R : Ω
C : F

Audio ICs

●Operation notes

(1) Control pin (CTL)

The level of the DC voltage applied to the control pin should be in the range 0V to V_{CC} . Appropriate switching may not be possible in the region of the threshold voltage. Allow sufficient margin when setting this voltage.

(2) Recommended operating range

Provided the IC is operated within the operating temperature range and within the recommended operating conditions, the general circuit functions are guaranteed to operate correctly, and there will not be significant changes in the electrical characteristics.

(3) Application example

Provided the circuit constants in the application example circuit are used, the application circuit should function correctly. However, we recommend that you confirm the characteristics of the circuit in actual use, and take note of the cautionary items described above. If you change the circuit constants, check both the static and transient characteristics of the circuit, and allow sufficient margin to accommodate variations in both the IC and the external components.

(4) License

The ICs are manufactured under license from BBB Sound Inc. (U.S.A.). A license agreement with BBB Sound Inc. is required to use this component.

●Electrical characteristic curves

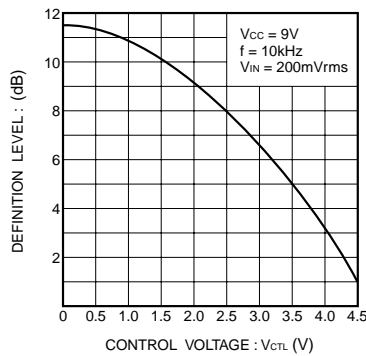

Fig. 3 Definition level vs. control voltage

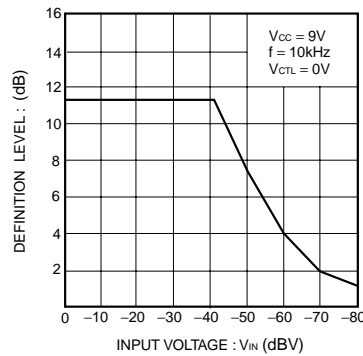
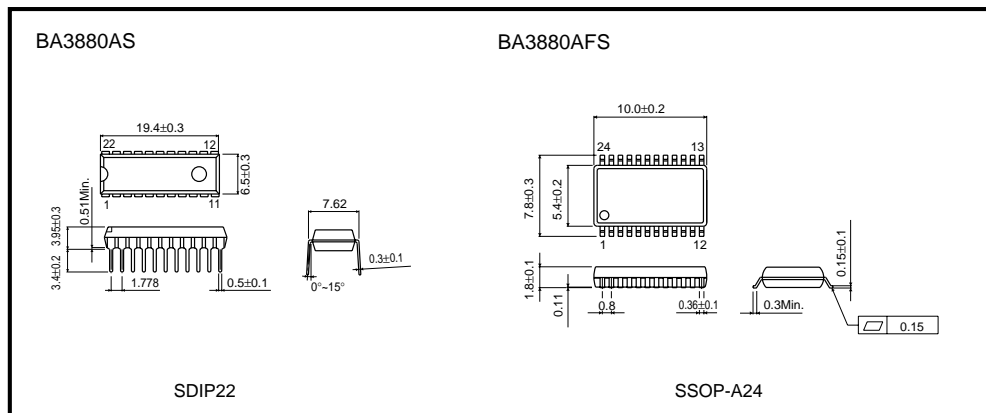

Fig. 4 Definition level vs. input voltage

●External dimensions (Units : mm)



This datasheet has been downloaded from:

www.DatasheetCatalog.com

Datasheets for electronic components.



LittleDiode supplies new, hard to find or obsolete electronic components and semiconductors all over the world.

With over two million different components listed you are sure to find the part you need.

Feel free to visit us today at our online store:

LittleDiode.com

Looking forward to providing you with the best possible service.