

System power supply for car stereos

BA3915B

The BA3915B is an one-chip power supply IC for use in car audio systems. The IC has seven output systems : one 5V output (V_{DD}), four 8.5V outputs (COM, FM, AM, AR), and two high-side switch outputs (ANT, AMP). The 5V outputs operate all the time if only the BCAD input is provided. The other outputs operate with BACKUP and ACC inputs, and their ON / OFF is controlled by the STANDBY and MODE inputs.

●Applications

Car audio systems

●Features

- 1) ACC and BACKUP voltages are monitored, compared with the internally set values; one-shot pulses are output to MUTE, which synchronizes with the rising and falling of the STANDBY input.
- 2) ACC voltage is monitored, compared with the internally set value, and the result is output to ACCB.
- 3) All outputs use a PNP transistor with low saturation voltage.
- 4) Output current limit circuit prevents damage to the IC due to short-circuiting.
- 5) Overvoltage protection circuit provides protection against surges from the ACC or BACKUP input.
- 6) Compact 16-pin POWER package allows large power dissipation.

●Absolute maximum ratings ($T_a = 25^\circ\text{C}$)

Parameter	Symbol	Limits	Unit
Power supply voltage	BACKUP/ACC	24	V
Power dissipation	P_d	3400	mW
Operating temperature	T_{opr}	$-30 \sim +85$	$^\circ\text{C}$
Storage temperature	T_{stg}	$-55 \sim +150$	$^\circ\text{C}$
Peak applied voltage	BACKUP/BCAP/ACC Peak	50*1	V

*1 $t_r \geq 1$ ms, applied time is less than 200 ms.

●Recommended operating conditions ($T_a = 25^\circ\text{C}$)

Parameter	Symbol	Min.	Typ.	Max.	Unit
Recommended power supply voltage	BACKUP/BCAP/ACC	10	13.2	16	V
Operable voltage	BACKUP/BCAP/ACC	9.6	13.2	24	V
MUTE section operating voltage	BACKUP	4.0	—	—	V

Note: Not intended to ensure electrical characteristics (in particular, during a voltage drop)

Note: When the BACKUP input voltage becomes less than about 3 V, all the outputs except V_{DD} are shut down together with the logic bias voltage.

● Block diagram

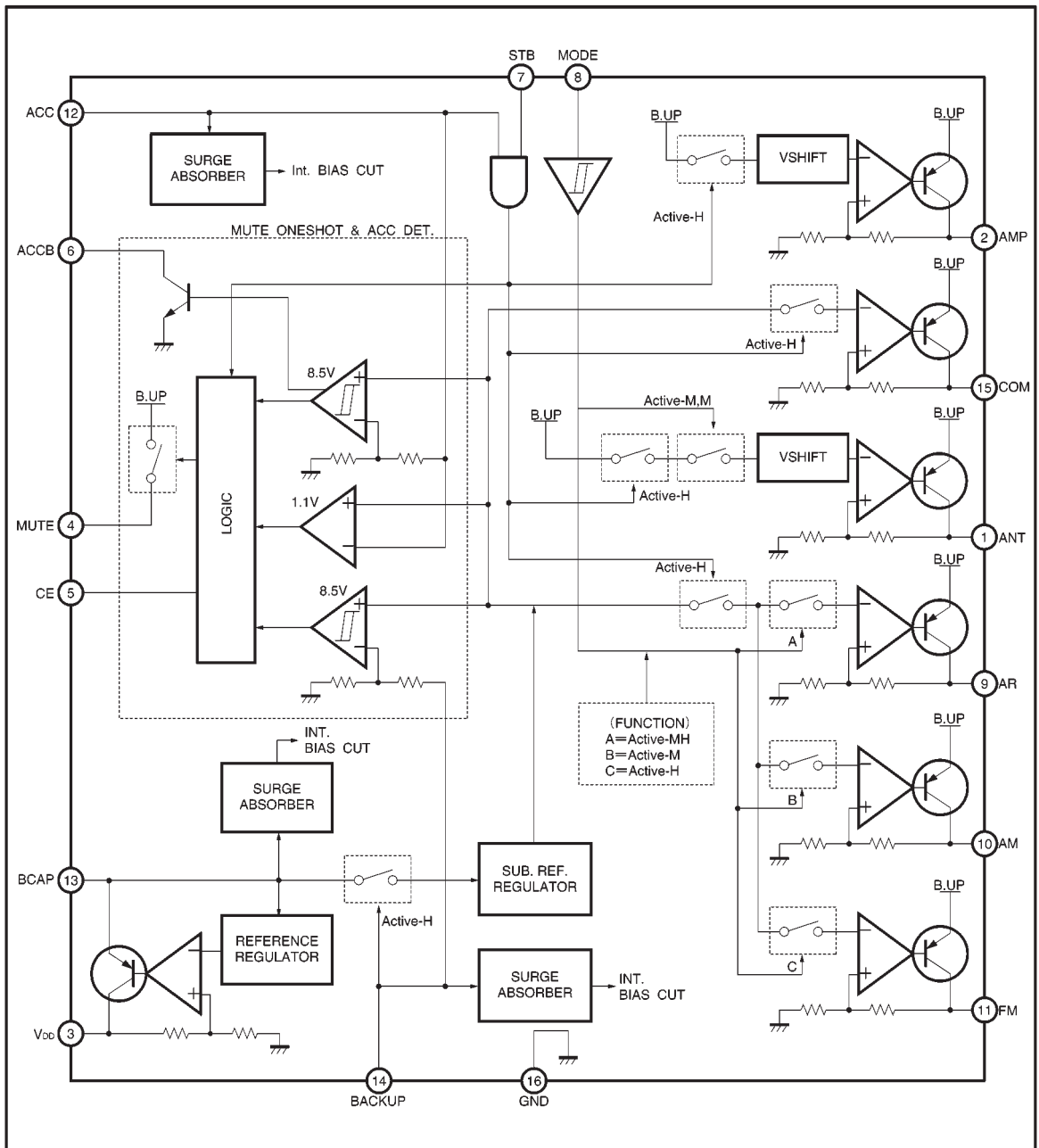

● Pin descriptions (Ta = 25°C, BACKUP / ACC = 13.2V)

Pin No.	Pin name	Function
1	ANT	12.6V power supply output pin for antenna drive
2	AMP	12.6V power supply output pin for amplifiers
3	V _{DD}	5.0V power supply output pin for microcontroller; always output when BACKUP input is provided
4	MUTE	One-shot pulse output
5	CE	Capacitor connection pin for one-shot pulse time constant (TM) setting
6	ACCB	NPN transistor open collector output; ON when ACC is 8.5 V (typical) or more
7	STANDBY	Only V _{DD} is output when LOW; COM, FM, AM, AR, ANT, and AMP can be output when HIGH
8	MODE	3-mode input controls ON/OFF of FM, AM, AR, ANT, and AMP outputs
9	AR	8.5V power supply output pin for AR
10	AM	8.5V power supply output pin for AM tuner
11	FM	8.5V power supply output pin for FM tuner
12	ACC	Accessory power supply connection
13	BCAP	Capacitor connection pin for V _{DD} backup
14	BACKUP	Backup power supply connection
15	COM	8.5V power supply output pin for COMMON
16	GND	Ground

● Input / output circuits

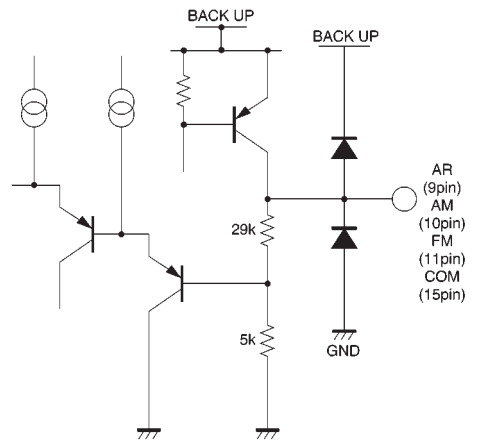
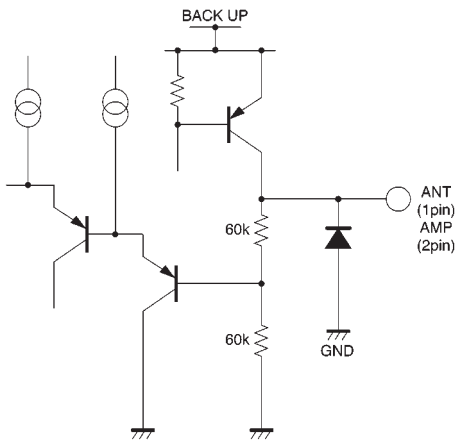
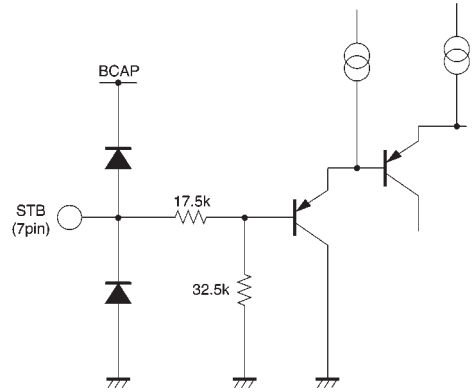
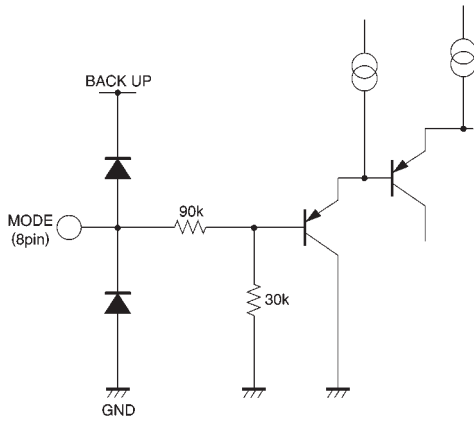

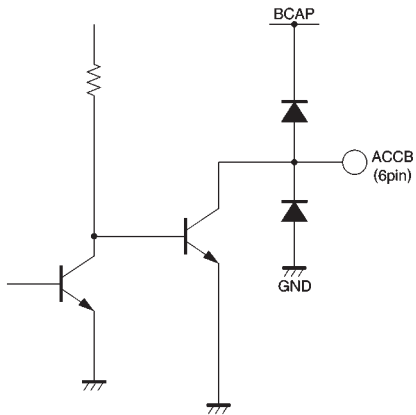
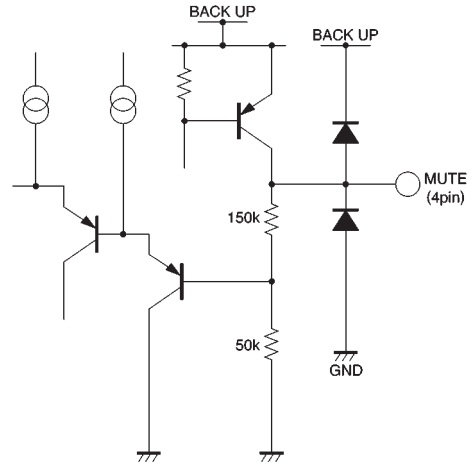
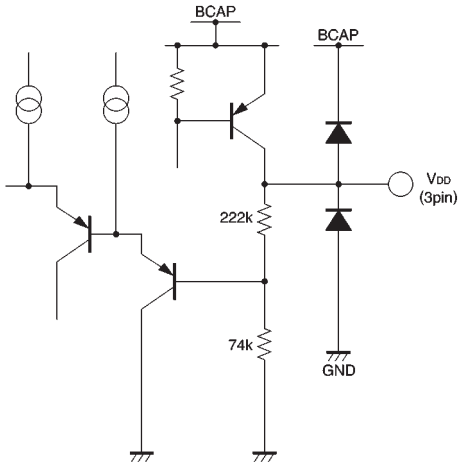

●Electrical characteristics (unless otherwise noted, Ta = 25°C, BACKUP / ACC = 13.2V)

Parameter	Symbol	Min.	Typ.	Max.	Unit	Conditions	Measurement circuit
BCAP supply current 1	ICAP1	—	0.40	0.55	mA	BCAP=12.5V, BUP=0V	Fig.1
BACKUP standby supply current	IBUP	—	0.18	0.20	mA	BUP=13.2V, BCAP=12.5V	Fig.1
BCAP supply current 2	ICAP2	—	1.30	1.75	mA	BUP=13.2V, BCAP=12.5V	Fig.1
〈V _{DD} 〉							
Output voltage	V _{O1}	4.75	5.00	5.25	V	I _{O1} =80mA	Fig.1
Voltage regulation	ΔV _{O11}	—	100	300	mV	I _{O1} =80mA	Fig.1
Load regulation	V _{O11}	—	50	170	mV	I _{O1} =0→80mA	Fig.1
Minimum I/O voltage differential	ΔV _{O12}	—	0.4	0.7	V	I _{O1} =80mA	Fig.1
Output current capacity	I _{O1}	80	—	—	mA		Fig.1
Ripple rejection ratio	RR1	41	45	—	dB	f=100Hz, V _{RR} =-10dBV	Fig.2
〈COM〉							
Output voltage	V _{O2}	8.05	8.50	8.95	V	I _{O2} =300mA	Fig.1
Voltage regulation	ΔV _{O21}	—	100	300	mV	I _{O2} =300mA	Fig.1
Load regulation	V _{O21}	—	50	170	mV	I _{O2} =0→300mA	Fig.1
Minimum I/O voltage differential	ΔV _{O22}	—	0.4	0.7	V	I _{O2} =300mA	Fig.1
Output current capacity	I _{O2}	300	—	—	mA		Fig.1
Ripple rejection ratio	RR2	41	45	—	dB	f=100Hz, V _{RR} =-10dBV	Fig.2
〈FM〉							
Output voltage	V _{O3}	8.05	8.50	8.95	V	I _{O3} =300mA	Fig.1
Voltage regulation	ΔV _{O31}	—	100	300	mV	I _{O3} =300mA	Fig.1
Load regulation	V _{O31}	—	50	170	mV	I _{O3} =0→300mA	Fig.1
Minimum I/O voltage differential	ΔV _{O32}	—	0.4	0.7	mV	I _{O3} =300mA	Fig.1
Output current capacity	I _{O3}	300	—	—	mA		Fig.1
Ripple rejection ratio	RR3	41	45	—	dB	f=100Hz, V _{RR} =-10dBV	Fig.2
〈AM〉							
Output voltage	V _{O4}	8.05	8.50	8.95	V	I _{O4} =200mA	Fig.1
Voltage regulation	ΔV _{O41}	—	100	300	mV	I _{O4} =200mA	Fig.1
Load regulation	V _{O41}	—	50	170	mV	I _{O4} =0→200mA	Fig.1
Minimum I/O voltage differential	ΔV _{O42}	—	0.4	0.7	V	I _{O4} =200mA	Fig.1
Output current capacity	I _{O4}	200	—	—	mA		Fig.1
Ripple rejection ratio	RR4	36	40	—	dB	f=100Hz, V _{RR} =-10dBV	Fig.2
〈ANT〉							
Minimum I/O voltage differential	ΔV _{O52}	—	0.6	1.1	V	I _{O5} =250mA	Fig.1
Load regulation	V _{O51}	—	180	540	mV	I _{O5} =0→250mA	Fig.1
Output current capacity	I _{O5}	250	—	—	mA		Fig.1
〈AMP〉							
Minimum I/O voltage differential	ΔV _{O62}	—	0.6	1.1	V	I _{O6} =100mA	Fig.1
Load regulation	V _{O61}	—	100	300	mV	I _{O6} =0→100mA	Fig.1
Output current capacity	I _{O6}	100	—	—	mA		Fig.1

Parameter	Symbol	Min.	Typ.	Max.	Unit	Conditions	Measurement circuit
〈AR〉							
Output voltage	V_{O7}	8.05	8.50	8.95	V	$I_{O7}=200\text{mA}$	Fig.1
Voltage regulation	ΔV_{O71}	—	100	300	mV	$I_{O7}=200\text{mA}$	Fig.1
Load regulation	V_{O71}	—	50	170	mV	$I_{O7}=0\rightarrow 200\text{mA}$	Fig.1
Minimum I/O voltage differential	ΔV_{O72}	—	0.4	0.7	V	$I_{O7}=200\text{mA}$	Fig.1
Output current capacity	I_{O7}	200	—	—	mA		Fig.1
Ripple rejection ratio	RR7	41	45	—	dB	$f=100\text{Hz}$, $V_{RR}=-10\text{dBV}$	Fig.2
〈MUTE〉							
Output voltage	V_{O8}	4.3	4.9	5.5	V	$I_{O8}=10\text{mA}$	Fig.3
Pulse CE output current	I_{TM}	0.6	1.0	1.4	μA	$I_{O8}=10\text{mA}$	Fig.3
Pulse threshold voltage	V_{TM}	0.9	1.0	1.1	V	$I_{O8}=10\text{mA}$	Fig.3
Pulse width	TM	—	0.1	—	SEC	$CE=0.1\mu\text{F}$	Fig.3
〈ACC〉							
Output A rising threshold	V_{TAR1}	1.0	1.1	1.2	V	TM is counted from $ACC = V_{TAR2}$	Fig.3
Pulse A rising threshold	V_{TAR2}	8.0	8.5	9.0	V		Fig.3
Output A falling threshold	V_{TAF1}	8.0	8.5	9.0	V		Fig.3
Pulse A falling threshold	V_{TAF2}	1.0	1.1	1.2	V		Fig.3
〈BACKUP〉							
Output B rising threshold	V_{TBR1}	4.7	5.0	5.3	V		Fig.3
Pulse B rising threshold	V_{TBR2}	8.0	8.5	9.0	V		Fig.3
Output B falling threshold	V_{TBF1}	8.0	8.5	9.0	V		Fig.3
Pulse B falling threshold	V_{TBF2}	4.7	5.0	5.3	V		Fig.3
〈STANDBY〉							
Output S rising threshold	V_{TSR1}	1.6	1.9	2.2	V		Fig.3
Pulse S rising threshold	V_{TSR2}	2.6	2.9	3.2	V		Fig.3
Output S falling threshold	V_{TSF1}	2.6	2.9	3.2	V		Fig.3
Pulse S falling threshold	V_{TSF2}	1.6	1.9	2.2	V		Fig.3
〈MODE〉							
OFF MODE threshold	V_{TR1}	—	—	1.1	V	OFF MODE	Fig.1
AM ON threshold	V_{TR2}	1.25	1.5	1.75	V	AM MODE WITH ANT, AMP & AR	Fig.1
FM ON threshold	V_{TR3}	2.5	3.0	3.5	V	FM MODE WITH ANT, AMP & AR	Fig.1
AM hysteresis width	V_{AHY}	0.1	0.2	0.3	V	AM MODE WITH ANT, AMP & AR	Fig.1
FM hysteresis width	V_{FHY}	0.1	0.2	0.3	V	FM MODE WITH ANT, AMP & AR	Fig.1
Input current	I_{MO}	15	40	65	μA	MODE=5V	Fig.1
〈STANDBY〉							
Standby level	V_{SB1}	—	—	2.4	V		Fig.1
Active level	V_{SB2}	3.2	—	—	V		Fig.1
Input current	V_{STB}	75	100	125	μA	STANDBY=5V	Fig.1
〈ACCB〉							
Detected voltage	V_{DET}	8.0	8.5	9.0	V	Same as V_{TAF}	Fig.1
Output saturation voltage when ON	V_{SAT1}	—	0.5	0.9	V	ACC=13.2V $I_{O9}=2\text{mA}$	Fig.1

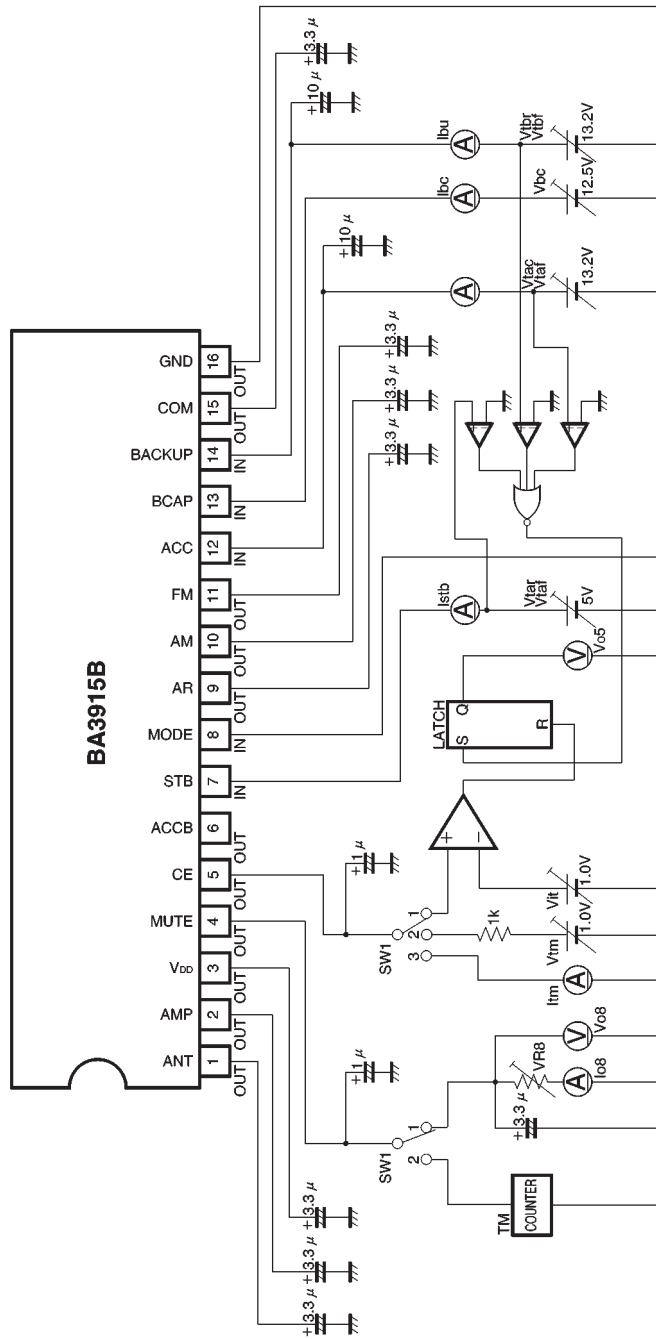
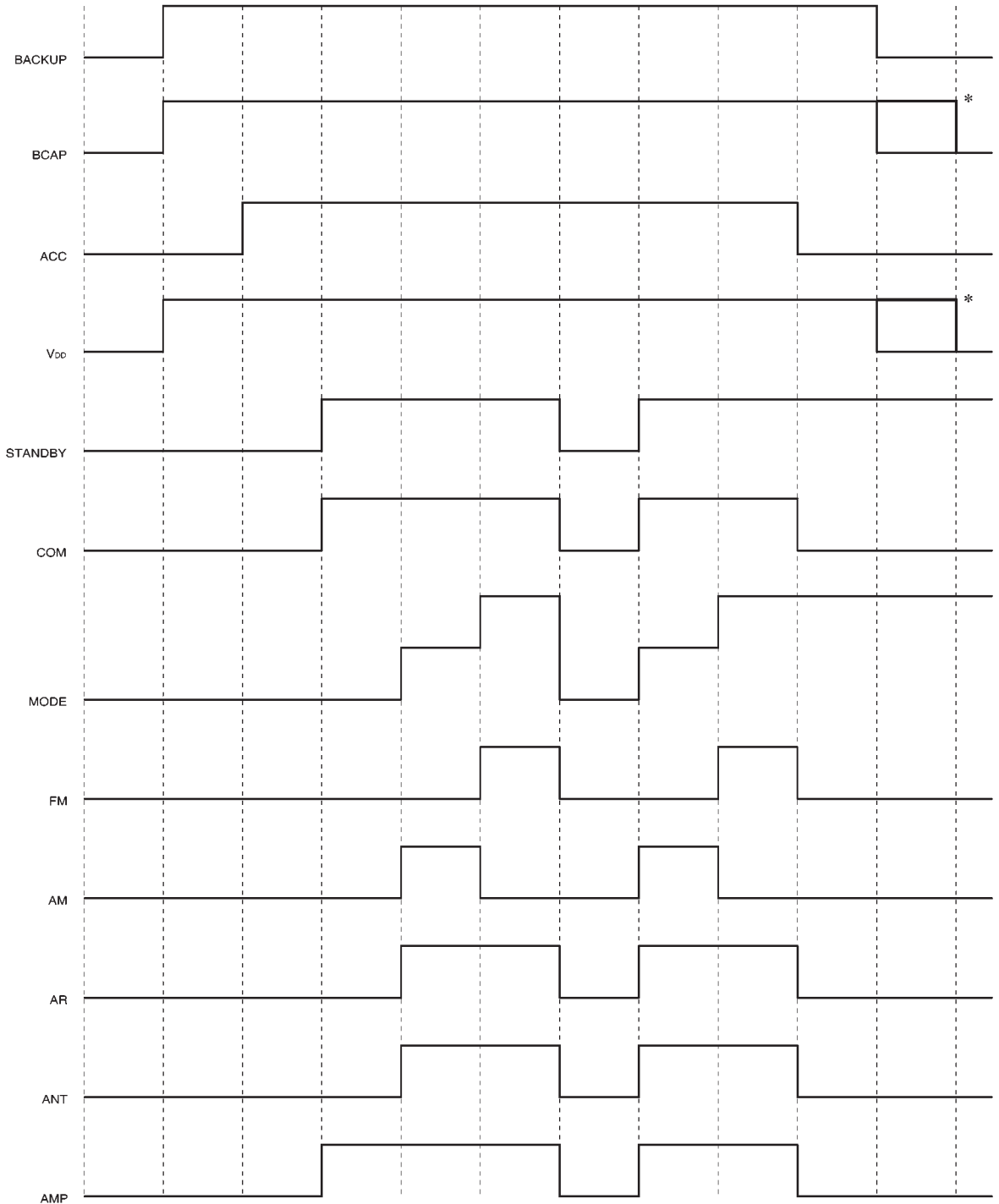

Fig.3

● Input / output timing chart



* ... When an external capacitor is connected

● MUTE timing chart

Function-1

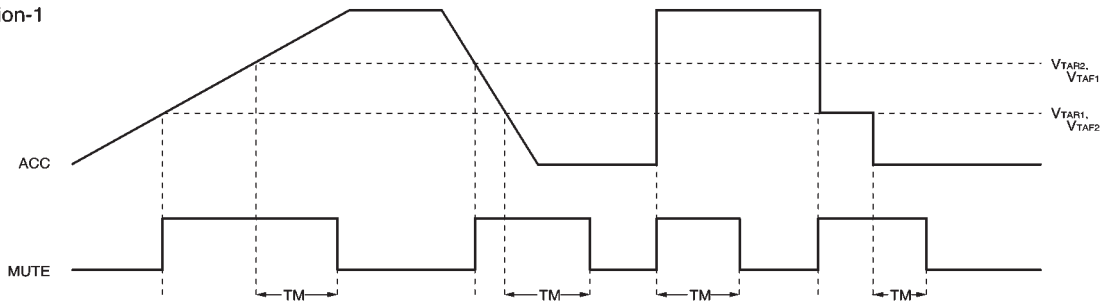

Function-2

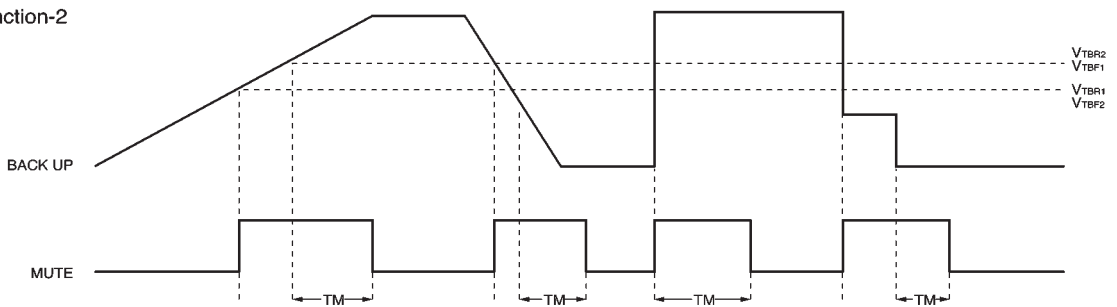

Function-3

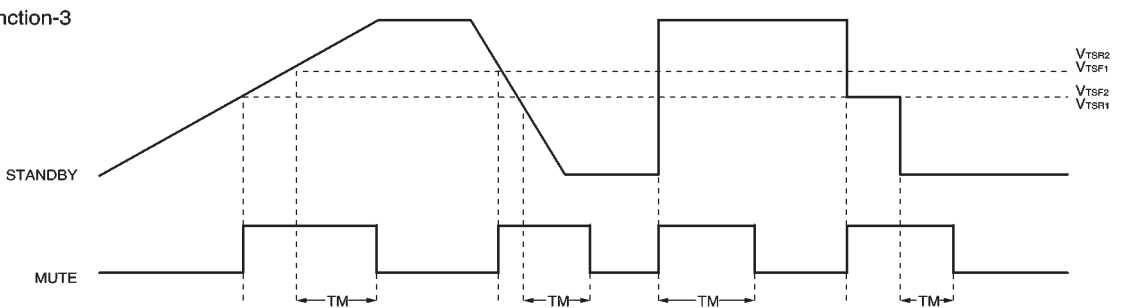

ACCB timing chart

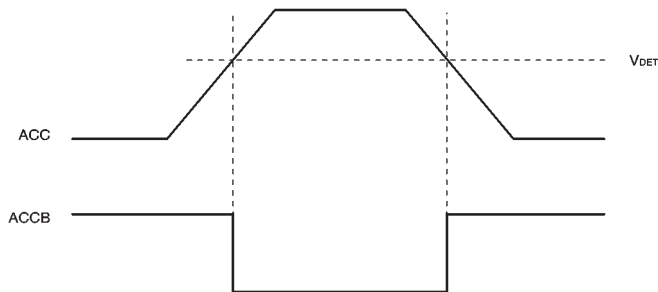

● AM / FM output timing chart

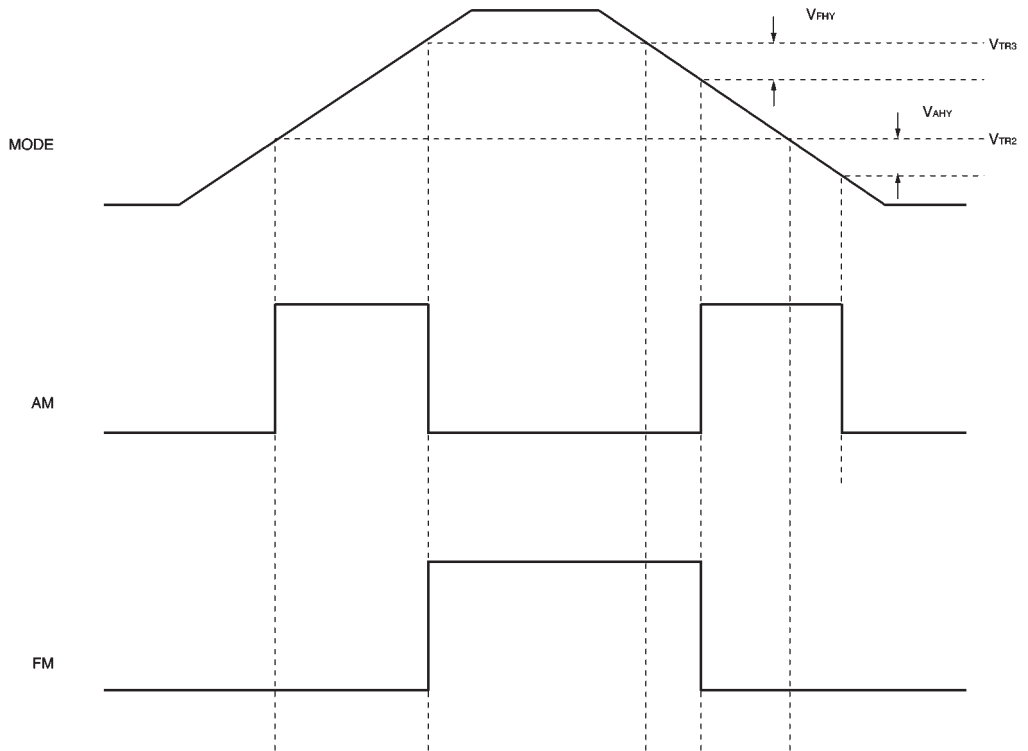

● Estimate of allowable power dissipation

Except under transitional conditions, the power dissipation of this IC is 3.4W per unit at 25°C. See Fig. 4 for heat reduction characteristics, including some cases where heat sinks are used.

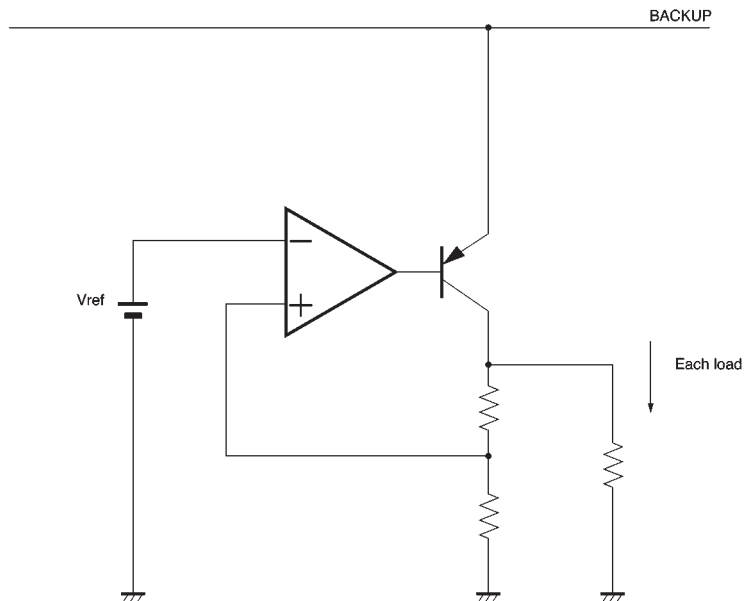

A = maximum BACKUP voltage

B = maximum BCAP voltage

I₁ = maximum output current for V_{DD} (80mA)

I₂ = maximum output current for COM (300mA)

I₃ = maximum output current for FM (300mA)

I₄ = maximum output current for AM (200mA)

I₅ = maximum output current for AR (200mA)

I₆ = maximum output current for ANT (250mA)

I₇ = maximum output current for AMP (100mA)

- | | |
|---|--|
| • Power consumed by V _{DD} 5.0V | $P_1 = (B - 5.0V) \times I_1 + (I_1 / 16 + I_1 / 10) \times B$ |
| • Power consumed by COM 8.5V | $P_2 = (A - 8.5V) \times I_2 + (I_2 / 60 + I_2 / 10) \times A$ |
| • Power consumed by FM 8.5V | $P_3 = (A - 8.5V) \times I_3 + (I_3 / 60 + I_3 / 10) \times A$ |
| • Power consumed by AM 8.5V | $P_4 = (A - 8.5V) \times I_4 + (I_4 / 40 + I_4 / 10) \times A$ |
| • Power consumed by AR 8.5V | $P_5 = (A - 8.5V) \times I_5 + (I_5 / 40 + I_5 / 10) \times A$ |
| • Power consumed by ANT | $P_6 = (0.6V) \times I_6 + (I_6 / 50 + I_6 / 10) \times A$ |
| • Power consumed by AMP | $P_7 = (0.6V) \times I_7 + (I_7 / 50 + I_7 / 10) \times A$ |
| • Power consumed internally by each circuit | $P_8 = A \times \text{circuit current (about 10mA)}$ |

$$P_{MAX} = P_1 + P_2 + (P_3 \text{ or } P_4, \text{ whichever is larger}) + P_5 + P_6 + P_7 + P_8$$

● Operation notes

(1) Although the quality of this IC is rigorously controlled, the IC may be destroyed when the supply voltage or the operating temperature exceeds their absolute maximum ratings. Because short mode or open mode cannot be specified when the IC is destroyed, be sure to take physical safety measures, such as fusing, if any of the absolute maximum ratings might be exceeded.

(2) Operating power supply voltage

When operating within the proper ranges of power supply voltage and ambient temperature, most circuit functions are guaranteed. Although the rated values of electrical characteristics cannot be absolutely guaranteed, characteristic values do not change drastically within the proper ranges.

(3) Power dissipation (Pd)

Refer to the power dissipation characteristics (Fig. 4) and the rough estimation of IC power dissipation given on a separate page. Make sure your design allows the maximum required power within the operating temperature range.

(4) Overvoltage protection circuit

The overvoltage protection circuit turns OFF all outputs when the potential difference between BACKUP (pin 14), BCAP (pin 13), or ACC (pin 12) and GND (pin 16) is more than about 26V at normal temperature. Make sure to use the IC within this voltage limit.

(5) Preventing oscillation at each output

To stop output oscillation, make sure to connect a capacitor having a capacitance of 10 μ F or greater between GND and each of the ANT (pin 1), AMP (pin 2), V_{DD} (pin 3), AM (pin 10), FM (pin 11), and COM (pin 15) output pins. We recommend using a tantalum electrolytic capacitor whose capacitance is unsusceptible to temperature.

(6) Overcurrent protection circuit

An overcurrent protection circuit is installed on the ANT (pin 1), AMP (pin 2), V_{DD} (pin 3), AM (pin 10), FM (pin 11), and COM (pin 15) outputs, based on the respective output current. This prevents IC destruction due to overcurrent, by limiting the current with a curve shape of "7" in the voltage-current graph. The IC is designed with margins so that current flow will be restricted and latching will be prevented even if a large current suddenly flows through

a large capacitor. The circuit should be carefully set because output current is further restricted when output voltage is less than 1V_F (considered as short mode).

(7) Thermal protection circuit

A built-in thermal protection circuit prevents thermal damage to the IC. All outputs except V_{DD} are switched OFF when the circuit operates, and revert to the original state when the temperature drops to a certain level.

(8) BACKUP-ACC potential difference

If the BACKUP voltage exceeds the ACC voltage, a current flows through a protection diode connected internally between BACKUP and ACC. If the potential difference is more than 1V_F, this diode is fully turned on.

(9) BCAP pin external diode

Voltage is supplied to BCAP from BACKUP through an external diode. The maximum current consumption is about 100mA. A reverse bias will be applied to the diode if the BACKUP pin becomes 0V. Select a diode that has sufficient electrical characteristics to cope with the above conditions.

(10) Grounding

Each ground trace must be adequately short from GND (pin 16). Make sure to arrange the ground traces in a pattern that prevents mutual interference.

(11) We recommend installing a bypass line in your application if there is a mode where potential difference between each output and input (V_{CC}) or GND is reversed from the normal state.

●Electrical characteristic curves

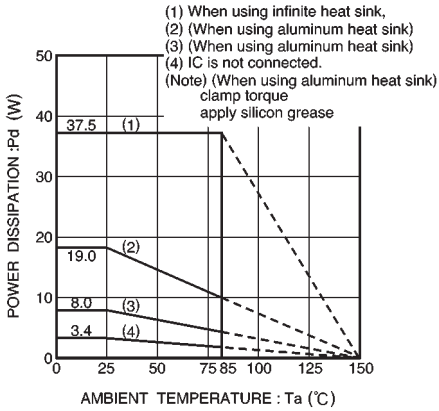

Fig.4 Thermal derating curve

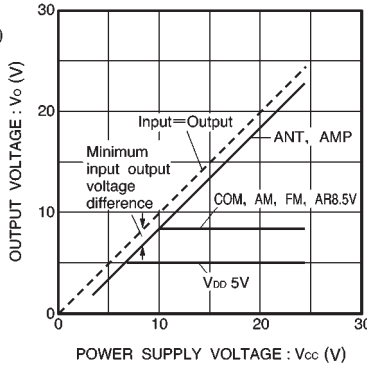

Fig.5 Output voltage vs. power supply voltage

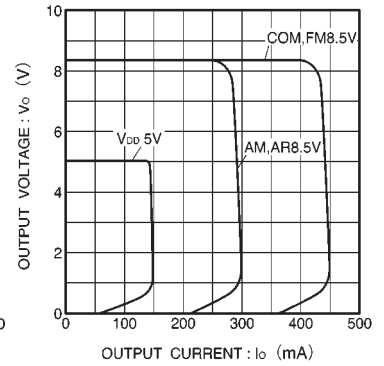

Fig.6 Output voltage vs. output current

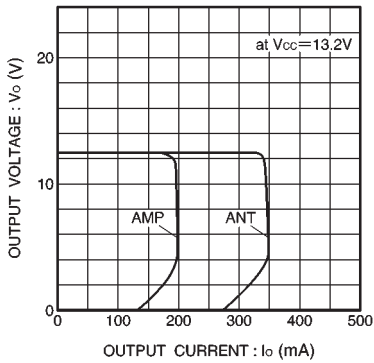

Fig.7 Output voltage vs. output current

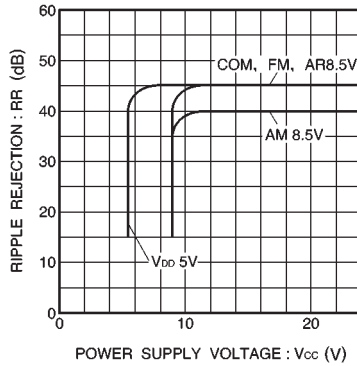
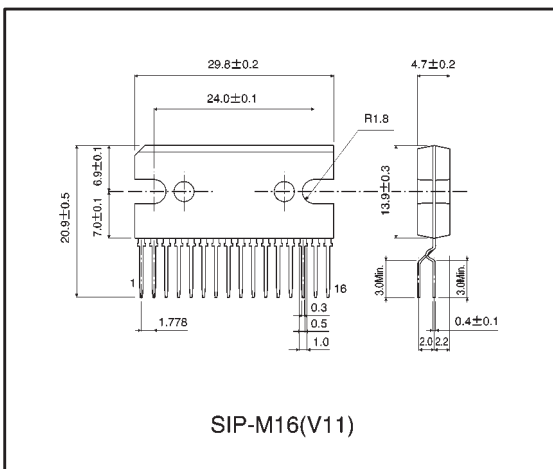

Fig.8 Ripple rejection ratio vs. power supply voltage

●External dimensions (Units: mm)



This datasheet has been downloaded from:

www.DatasheetCatalog.com

Datasheets for electronic components.



LittleDiode supplies new, hard to find or obsolete electronic components and semiconductors all over the world.

With over two million different components listed you are sure to find the part you need.

Feel free to visit us today at our online store:

LittleDiode.com

Looking forward to providing you with the best possible service.