

5 Channel Driver for with Regulator **BA5960FS**

●Description

The BA5960FS is a 5-channel Driver (4-channel BTL and 1-channel Loading driver) for an actuator and motor. Since the operational amplifier and variable regulator are built-in, it can be compatible with various applications.

●Features

- 1) 5-channel driver (4-channel BTL driver and 1-channel Loading driver)
- 2) Built-in thermal shut down circuit
- 3) The power supply is divided in 4 systems
- 4) Incorporates an operational amplifier.
- 5) Built-in stand-by function
- 6) Built-in variable regulator
- 7) Wide dynamic range
(5.4V typical at PreVcc=8V, PowVcc=8V, RL=8)
- 8) Mute operated individually Channel-1&2, Channel-3, Channel-4
- 9) Input pins consist of (+) and (-), therefore various input types are available such as differential input.
- 10) Built-in brake function (Loading driver)
- 11) Output voltage can be set up by voltage establishment terminal.

●Dimension (Units : mm)

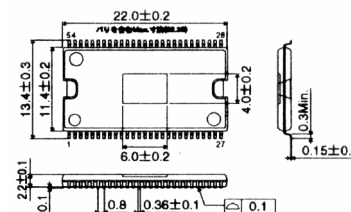

SSOP-A54

●Applications

Car CD, MD

●Absolute Maximum Ratings (Ta=25°C)

Parameter	Symbol	Limits	Unit
Supply voltage	PreVcc, PowVcc	18	V
Powerd dissipation	Pd	1.92 ¹	W
Output current	IOMAX	1 ²	A
Operating temperature range	Topr	-35 ~ +85	°C
Storage temperature range	Tstg	-55 ~ +150	°C

¹ Derating : 15.36mW/°C for operation above Ta=25°C.

² The output current must not exceed the maximum ASO

●Recommended Operating Conditions (Ta=25°C)

Parameter	Symbol	Min.	Typ.	Max.	Unit
Supply voltage	PreVcc	4.5	—	13.5	V
	PowVcc	4.5	—	PreVcc	V

● Electrical characteristics

(Unless otherwise noted, Ta=25°C, PreVcc=PowVcc1=PowVcc2=PowVcc3=8V, BIAS=1.65V, RL=8)

Parameter	Symbol	Min.	Typ.	Max.	Unit	Conditions	
Standby current (VCC+PowVcc)	IqST	—	—	1	mA	No load	
Quiescent current	Iq	—	22	30	mA	No load	
<BTL driver>							
Close loop gain	Gvc	10	11.5	14	dB	VIN=BIAS±0.5V	
Maximum output voltage	VOM	4.8	5.4	—	V	VIN=BIAS±1.65V	
Output offset voltage	VOO	-50	0	50	mV		
<Pre-operational amplifier & Operational amplifier>							
Input bias current	IB	—	—	0.3	μA		
Output offset voltage	VOP	-6	0	6	mV		
High level output voltage HI	VOH	7.5	—	—	V	BIAS=2.5V	
Low level output voltage LO	VOL	—	—	0.5	V	BIAS=2.5V	
Output sink current	ISO	1	—	—	mA		
Output source current	ISI	0.5	0.8	—	mA		
<Loading driver>							
Close loop gain	LDGVC	9	11	13	dB	LDCONT=1V	
Output voltage	FWD	VOL2F	4.8	5.4	—	V	LDCONT=4.5V
	REV	VOL2R	—	-5.4	-4.8		
Load regulation	FWD	VLI2F	—	0.45	0.9	V	LDCONT=4.5V VIL=100~500mA
	REV	VLI2R	—	0.45	0.9		
Line regulation	FWD	VLVSF	-0.5	—	0.5	V	Vcc=6~13V VIL=500mA LDCONT=1V
	REV	VLVSR	-0.5	—	0.5		
Output offset voltage	LDVOO	-50	0	50	mV	Brake mode	
<Regulator>							
Output voltage	Vreg	—	3.32	—	V	IL=50mA, Note) reference value	
Load regulation	VRL	-40	0	20	mV	IL=0~200mA, 3.3V set up	
Line regulation	VVCC	-20	10	40	mV	Vcc=6~13V, 3.3V set up	
REG.P pin voltage	VREGP	1.14	1.2	1.26	V		

※ This product is not designed for protection against radioactive rays.

● Application circuit

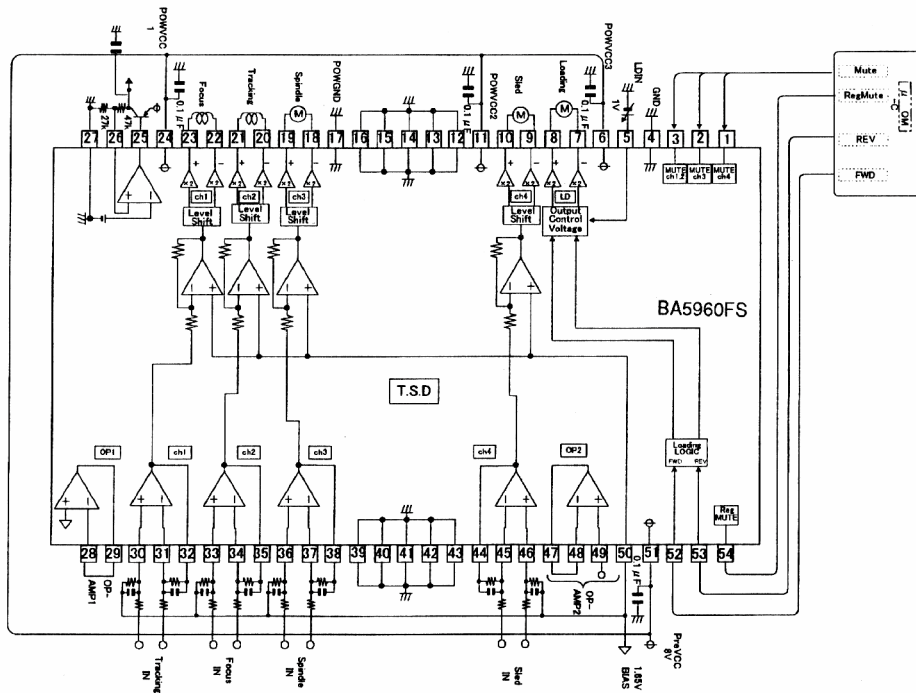



LittleDiode supplies new, hard to find or obsolete electronic components and semiconductors all over the world.

With over two million different components listed you are sure to find the part you need.

Feel free to visit us today at our online store:

LittleDiode.com

Looking forward to providing you with the best possible service.