

3-channel BTL driver for CD, CD-ROM, DVD, and DVD-ROM

BA5973FP

The BA5973FP is a 3-channel BTL driver developed for use as the actuator and loading motor driver for CD and DVD players. Since the gain and frequency characteristics for the actuator can be set to any desired value with external components, it can be used in a wide range of applications.

●Features

- | | |
|---|--|
| <ul style="list-style-type: none"> 1) 3-channel BTL driver for CD players. 2) The HSOP-28 package allows for the design of smaller sets. 3) Internal thermal shutdown circuit with hysteresis. | <ul style="list-style-type: none"> 4) Gain is adjustable with external resistor. 5) Contains both positive and negative input systems for compatibility with a variety of input formats such as reverse phase input. |
| | <ul style="list-style-type: none"> 6) Internal brake function. 7) Internal back-rush voltage protection diode. |

●Absolute maximum ratings (Ta = 25°C)

Parameter	Symbol	Limits	Unit
Power supply voltage	V _{CC} , PV _{CC}	13.5	V
Power dissipation	P _d	1.7*1	W
Allowable current	I _{Omax}	0.8*2	A
Operating temperature	T _{opr}	-35~+85	°C
Storage temperature	T _{stg}	-55~+150	°C

*1 Reduced by 13.6mW for each increase in Ta of 1°C over 25°C.

*2 Should not exceed Pd and ASO values.

●Recommended operating conditions

Parameter	Symbol	Limits	Unit
Power supply voltage (pre-block)	V _{CC}	4.5~+13.5	V
Power supply voltage (power-block)	PV _{CC}	4.5~+8.5	V

● Block diagram

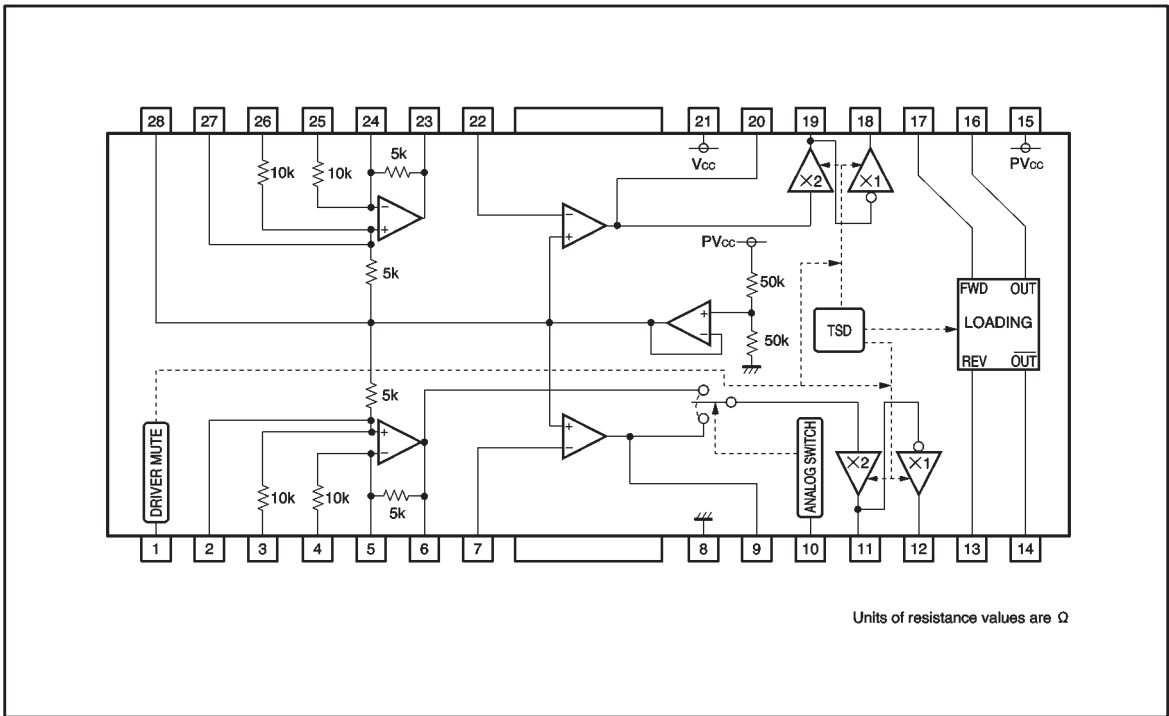

● Pin descriptions

Pin No.	Pin name	Function	Pin No.	Pin name	Function
1	MUTE	Mute*	15	PVcc	Vcc (output H bridge block)
2	OPIN11+	Op-amp non-inverse input	16	LDOUT+	Loading (+) output
3	FWD1	Forward input	17	FWD	Loading forward input*
4	REV1	Reverse input	18	OUT2+	Driver output
5	OPIN11-	Op-amp inverse input	19	OUT2-	Driver output
6	OPOUT11	Op-amp output	20	OPOUT22	Op-amp output
7	OPIN12-	Op-amp inverse input	21	Vcc	Vcc (pre-block)
8	GND	Substrate GND	22	OPIN22-	Op-amp inverse input
9	OPOUT12	Op-amp output	23	OPOUT21	Op-amp output
10	SW	Analog switch input*	24	OPIN21-	Op-amp inverse input
11	OUT1-	Driver output	25	REV2	Reverse input
12	OUT1+	Driver output	26	FWD2	Forward input
13	REV	Loading reverse input*	27	OPIN21+	Op-amp non-inverse input
14	LDOUT-	Loading (-) output	28	VREF	Reference voltage output

* Refer to the truth table in circuit operation explanation on page 695.

●Electrical characteristics (unless otherwise noted, $T_a = 25^\circ\text{C}$, $V_{CC} = 12\text{V}$, $PV_{CC} = 5\text{V}$, $f = 1\text{kHz}$, $R_L = 8\Omega$)

Parameter	Symbol	Min.	Typ.	Max.	Unit	Conditions
Quiescent current 1	I_{Q1}	—	11.5	21.5	mA	No load, loading driver in open mode
Quiescent current 2	I_{Q2}	—	17.0	32.0	mA	No load, loading driver in forward/reverse mode
Quiescent current 3	I_{Q3}	—	20.0	30.0	mA	No load, loading driver in brake mode
〈Internal reference〉						
Output voltage	V_{ref}	2.30	2.50	2.70	V	—
Maximum output current source	I_{OSO}	10	30	—	mA	—
Maximum output current sink	I_{OSI}	10	15	—	mA	—
〈Actuator driver〉						
Output offset voltage	V_{OO}	-70	0	70	mV	—
Maximum output amplitude	V_{OM}	3.5	4.0	—	V	—
Closed-loop voltage gain	G_{VC}	4.5	6.0	7.5	dB	—
Ripple rejection	RR	—	60	—	dB	$V_{osc}=0.1\text{V}_{rms}$, 100kHz
〈Analog switch input〉						
Input high level voltage	V_{IH}	2.0	—	V_{CC}	V	—
Input low level voltage	V_{IL}	-0.3	—	0.5	V	—
Input high level current	I_{IH}	—	90	135	μA	$V_{IN}=5\text{V}$
Input low level current	I_{IL}	-10	0	10	μA	$V_{IN}=0\text{V}$
〈Loading driver〉						
Output saturation voltage 1	V_{sat1}	—	0.4	0.8	V	Upper+lower $I_L=200\text{mA}$
Output saturation voltage 1 F / R difference	ΔV_{sat1}	—	—	0.1	V	F / R difference for output saturation voltage 1
Output saturation voltage 2	V_{sat2}	—	0.9	1.5	V	Output saturation voltage at $I_L=500\text{mA}$
〈Loading logic〉						
Input high level voltage	V_{IHLD}	2.0	—	V_{CC}	V	—
Input low level voltage	V_{ILLD}	-0.3	—	0.5	V	—
Input high level current	I_{IHLD}	—	180	270	μA	—
Input low level current	I_{ILLD}	-10	0	10	μA	—

©Not designed for radiation resistance.

● Measurement circuit

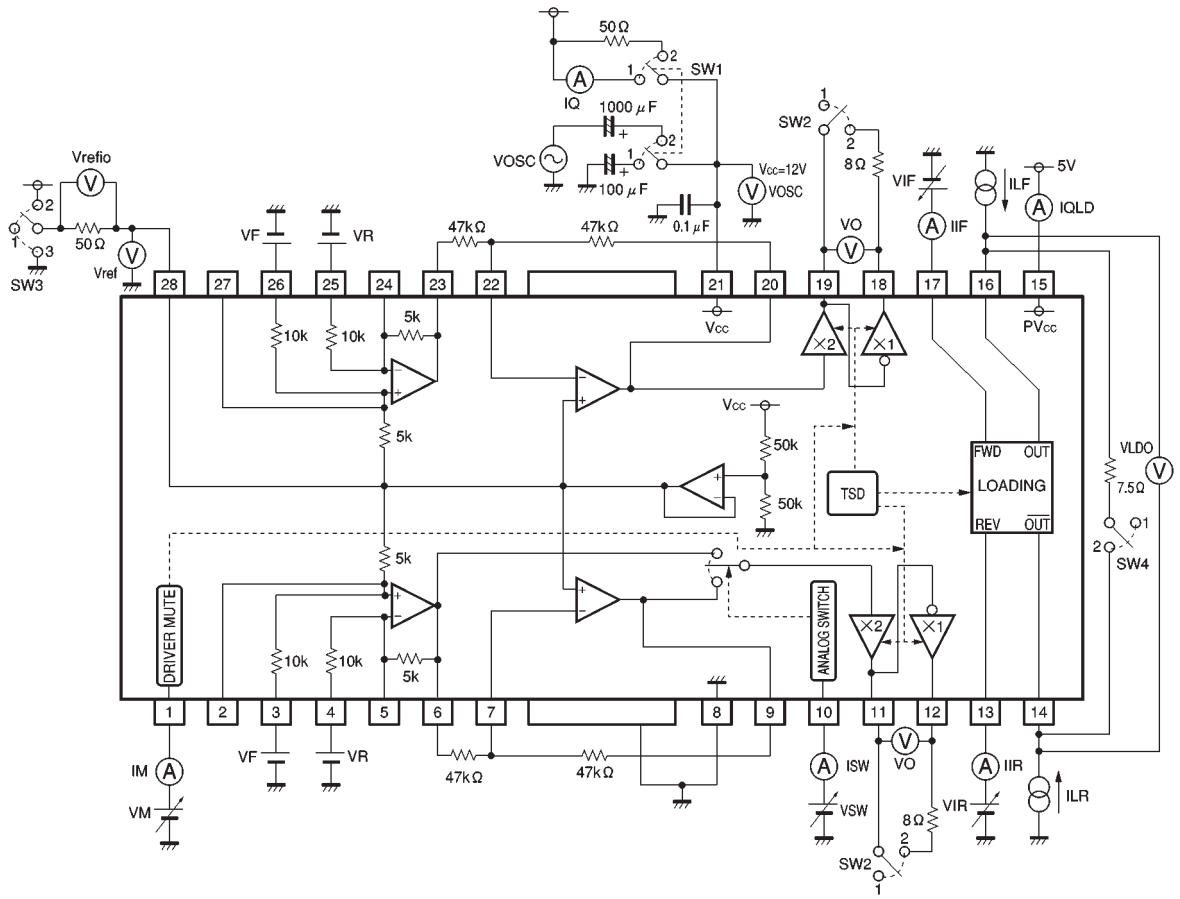

Fig.1

●Circuit operation

The analog switch pin 10, the mute pin 1, and the loading driver input logic operate as shown below.

(1) Mute input (pin 1) truth table

Input	Function
L	Mute on for actuator driver
H	Mute off for actuator driver

(2) Analog switch input (pin 10) truth table

Input	Function
L	Connects driver buffer input to pin 6
H	Connects driver buffer input to pin 9

(3) Loading driver logic input (pins 13 and 17) truth table

FWD	REV	Function
L	L	Open mode
L	H	Reverse mode
H	L	Forward mode
H	H	Brake mode

●Application example

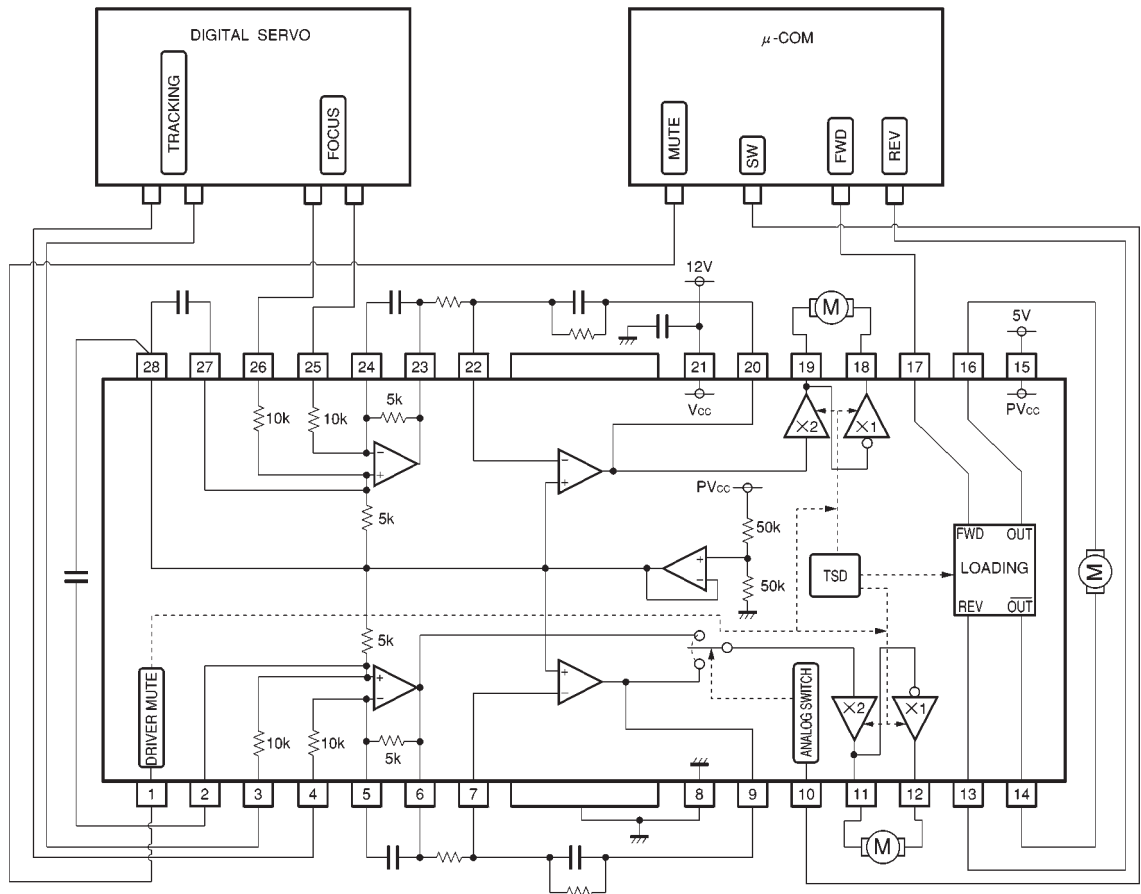

Fig.2

● Operation notes

(1) The BA5973FP contains a thermal shutdown circuit. When the chip temperature reaches 175°C (Typ.), the output current is muted. If the chip temperature then drops below 150°C (Typ.), then the driver circuits start up.

- (2) Connect a bypass capacitor (approx. 0.1μF) between the bases of the power supply pins of this IC.
- (3) Be sure to connect the radiation fins to an external ground.

● Electrical characteristic curves

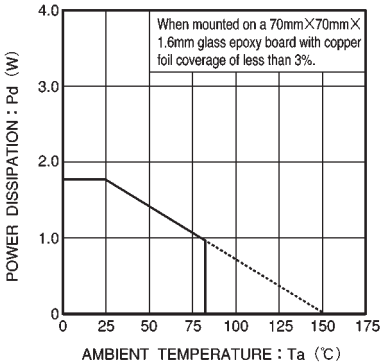

Fig.3 Thermal derating curve

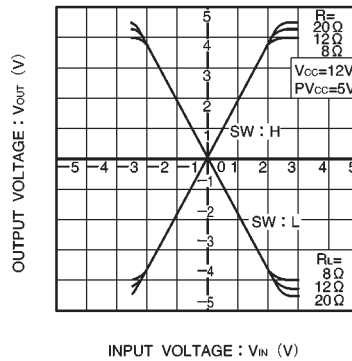

Fig.4 Channel 1 driver I/O characteristics (during load regulation)

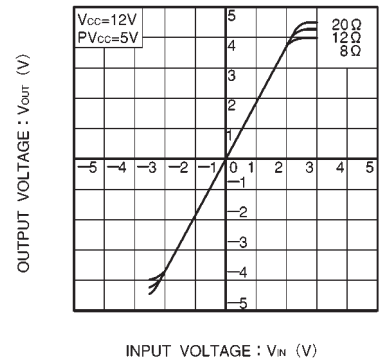

Fig.5 Channel 2 driver I/O characteristics

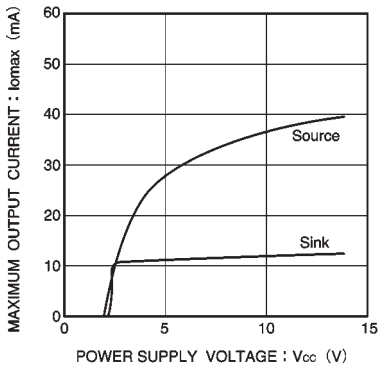

Fig.6 Power supply voltage vs. Vref amplifier maximum output current

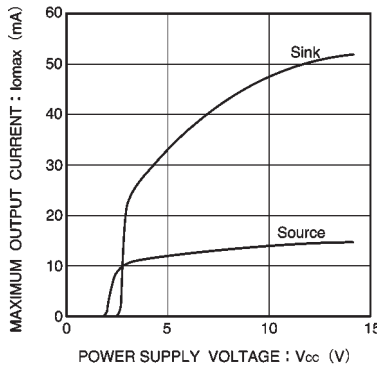

Fig.7 Power supply voltage vs. op-amp maximum output current

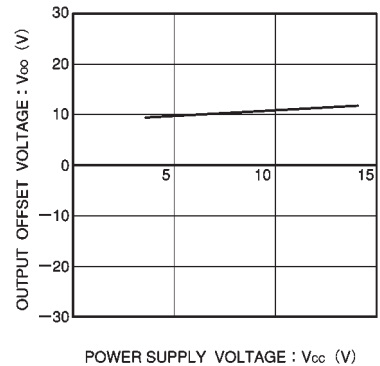

Fig.8 Power supply voltage vs. output offset voltage

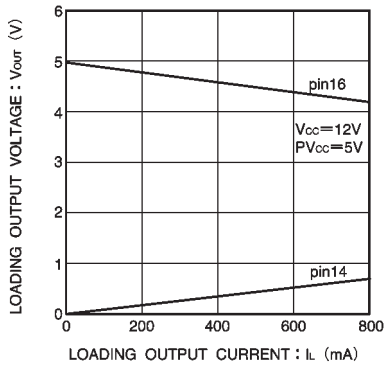

Fig.9 Loading output current vs. output voltage

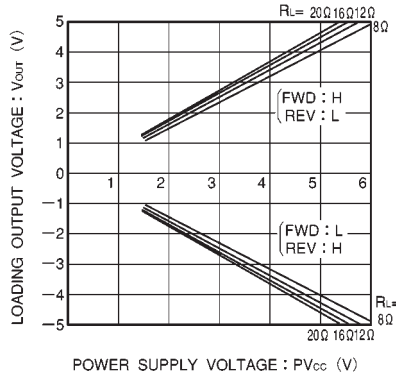
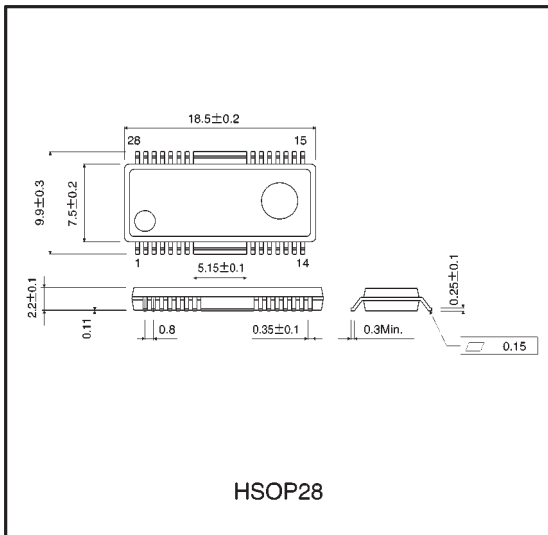

Fig.10 Loading output voltage vs. power supply voltage (during load regulation)

● External dimensions (Units: mm)





LittleDiode supplies new, hard to find or obsolete electronic components and semiconductors all over the world.

With over two million different components listed you are sure to find the part you need.

Feel free to visit us today at our online store:

LittleDiode.com

Looking forward to providing you with the best possible service.