

4-Channel BTL driver BA5994FM

● Description

The BA5994FM is a 4-channel BTL driver for an actuator and motor driver of CD/CD-ROM. (Inputs for the driver connect to an operational amplifier and it is compatible with various applications.)
Channel 2&3 include a short-brake function.

● Dimension (Units:mm)

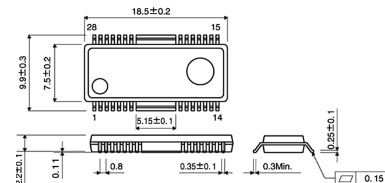

● Features

- 1) 4-channel BTL driver
- 2) Wide dynamic range (4V typical at PreVcc=12V, PowVcc=5V, RL=8)
- 3) Built-in thermal shut down circuit
- 4) Separating Vcc into Pre and Power (Power divides into Channel1&2 and Channel 3&4) makes for improved power efficiency, by a lower supply voltage drive
- 5) Mute operated individually with Channel 4 and Channel 1&2&3
- 6) All channels are mute in standby mode
- 7) Suitable for low operation voltage DSP by wide dynamic range pre operational amplifier.
- 8) Built-in short-brake circuit (Channel 2&3)

HSOP-M28

● Applications

CD, CD-ROM

● Absolute Maximum Ratings (Ta=25°C)

Parameter	Symbol	Limits	Unit
Supply voltage	PREVcc, POWVcc	13.5	V
Power dissipation	Pd	2.2 *1	W
Output current	IoMAX	1 *2	A
Operating temperature range	Topr	-35 ~ +85	°C
Storage temperature rang	Tstg	-55 ~ +150	°C

*1 On less than 3% (percentage occupied by copper foil), 70mm×70mm, t=1.6mm, glass epoxy mounting.
Derating: 17.6mW/°C for operation above Ta=25°C

*2 The output current must not exceed the maximum ASO.

● Recommended Operating Conditions (Ta=25 °C)

Parameter	Symbol	Min.	Typ.	Max.	Unit
Supply voltage	PREV _{CC}	4.5	-	13.2	V
	POWV _{CC}	4.5	-	PREV _{CC}	V

● Electrical characteristics

(Unless otherwise noted, Ta=25 °C, PreVcc=12V, PowVcc1=5V, PowVcc2=5V, V_{BIAS}=1.65V, V_{RL}=8 Ω)

Parameter	Symbol	Min.	Typ.	Max.	Unit	Conditions
Quiescent current	I _Q	-	20	30	mA	No load
All Channel Standby Current	I _{QST3}	-	-	1	mA	No load (Pre circuit current)
<Driver block>						
Output offset voltage	VOOF	70	0	70	mV	
Maximum output voltage 1	VOM1	3.6	4.0	-	V	CH1, 2 VIN=V _{BIAS} 1.65V
Maximum output voltage 2	VOM2	7.5	9	-	V	CH3, 4 VIN=V _{BIAS} 1.65V*
Closed loop voltage gain 1	GVC1	10	12	14	dB	CH1, 2 VIN=V _{BIAS} 0.5V
Closed loop voltage gain 2	GVC2	16	18	20	dB	CH3, 4 VIN=V _{BIAS} 0.5V*
<Pre operational amplifier>						
Input offset voltage	VOFOP	6	0	6	mV	
Input bias current	VBOP	-	-	300	nA	
High level output voltage	VOHOP	9	11	-	V	V _{BIAS} =6V
Low level output voltage	VOLOP	-	-	0.3	V	V _{BIAS} =6V
Output sink current	ISI	1	-	-	mA	Output to PreVcc by 50 Ω, V _{BIAS} =6V
Output source current	ISO	300	500	-	A	Output to GND by 50 Ω, V _{BIAS} =6V

○ This product is not designed for protection against radioactive rays. * PowVcc1=PowVcc2=12V

● Application circuit

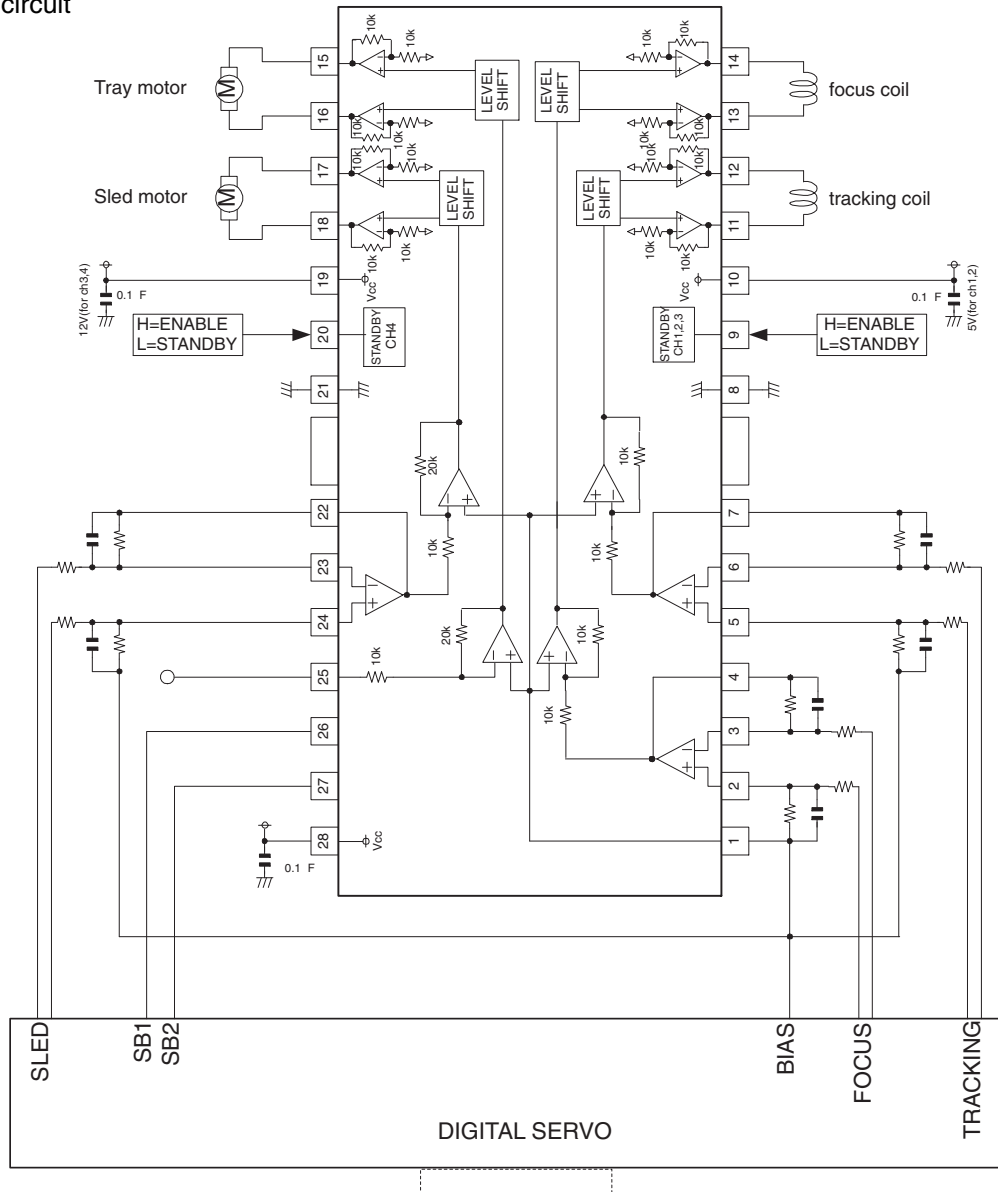



LittleDiode supplies new, hard to find or obsolete electronic components and semiconductors all over the world.

With over two million different components listed you are sure to find the part you need.

Feel free to visit us today at our online store:

LittleDiode.com

Looking forward to providing you with the best possible service.