

Dual output voltage regulator with power saving

BA61W12ST

The BA61W12ST is a general-purpose, low saturation power supply with two outputs : 10V, 1A and 5V, 500mA. The IC is available in a compact TO220FP-5 package. The outputs can be turned off during the power saving state with the built-in switch. Also built in the IC are an overcurrent protection circuit, an overvoltage protection circuit, and a thermal shutdown circuit.

●Applications

Car audio systems, VCRs, facsimiles, air conditioners, and other household and industrial equipment

●Features

- 1) Minimum I / O voltage differential is 0.5V or less.
- 2) Built-in protection circuits against overcurrent, over-voltage, and overheat.
- 3) Available in a compact TO220FP-5 package (pins are bendable).
- 4) Zero power saving current. (Typ.)

●Block diagram

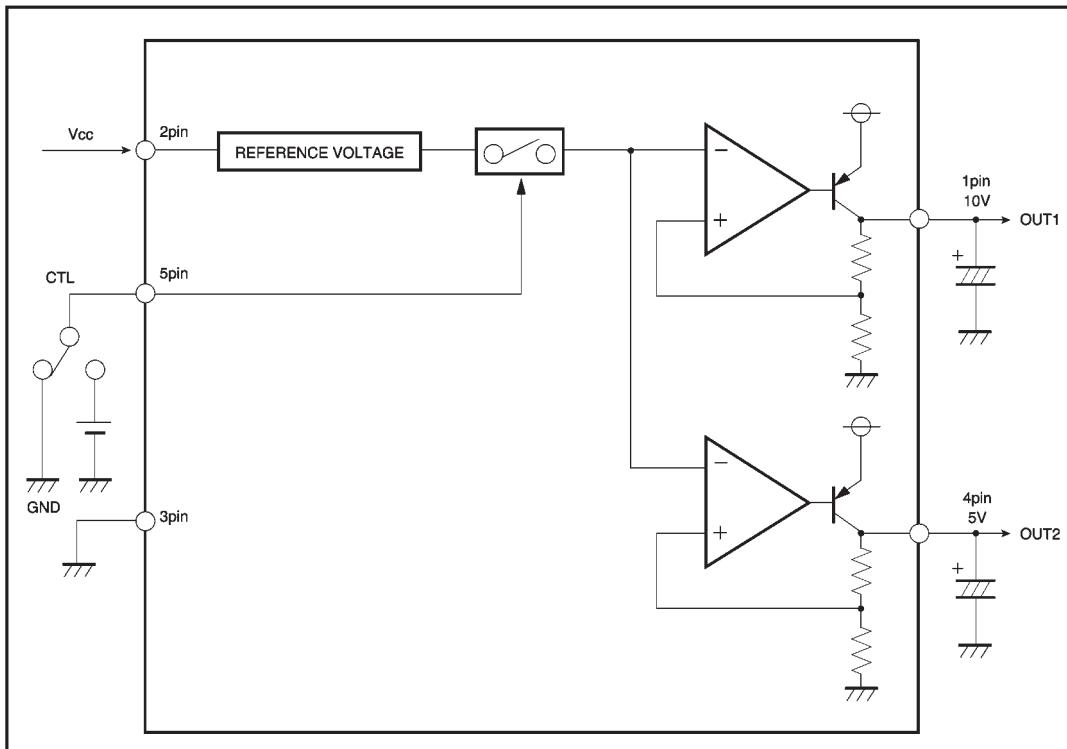

● Absolute maximum ratings ($T_a = 25^\circ\text{C}$)

Parameter	Symbol	Limits	Unit
Power supply voltage	V_{CC}	35	V
Power dissipation	P_d	2000*1	mW
Operating temperature	T_{opr}	$-40 \sim +85$	$^\circ\text{C}$
Storage temperature	T_{stg}	$-55 \sim +150$	$^\circ\text{C}$
Peak applied voltage	V_{surge}	50*2	V

*1 Reduced by 16mW for each increase in T_a of 1°C over 25°C .

*2 Applied time is less than 200 msec ($t_r \leq 1\text{msec}$)

● Recommended operating conditions ($T_a = 25^\circ\text{C}$)

Parameter	Symbol	Min.	Typ.	Max.	Unit
Power supply voltage	V_{CC}	11	15	25	V

● Pin descriptions

Pin No.	Pin name	Function
1	OUT1	Output 1 (10 V, 1 A)
2	V_{CC}	Power supply
3	GND	Ground
4	OUT2	Output 2 (5 V, 500 mA)
5	CTL	ON/OFF switch

● Input / output circuits

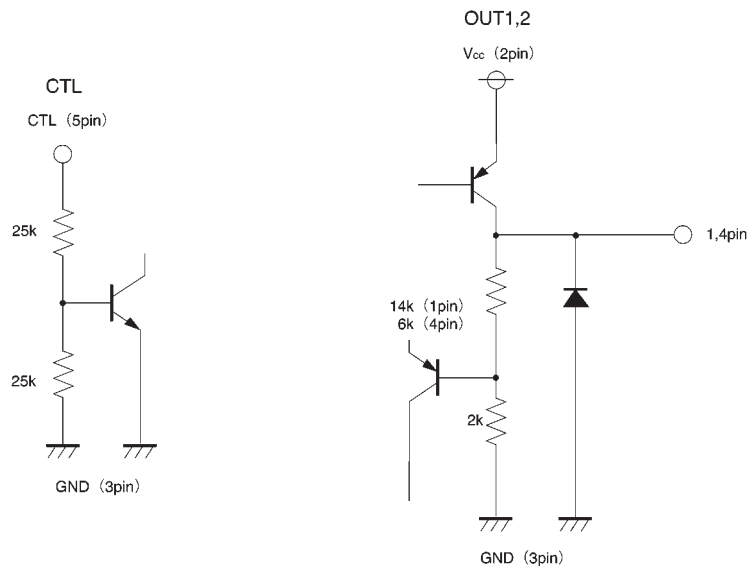

●Electrical characteristics (unless otherwise noted, Ta = 25°C and Vcc = 15.0V)

Parameter	Symbol	Min.	Typ.	Max.	Unit	Conditions	Measurement circuit
Power save supply current	I _{ST}	—	0	10	μA	OFF mode	Fig.4
Bias current	I _b	—	3.0	5.0	mA	ON mode	Fig.4
〈10V output section〉							
Output voltage 1	V _{O1}	9.5	10.0	10.5	V	I _{o1} =500mA	Fig.1
Minimum I/O voltage differential 1	ΔV _{O1}	—	0.3	0.5	V	I _{o1} =500mA V _{cc} =0.95V _{O1}	Fig.3
Output current capacity 1	I _{o1}	1.0	—	—	A		Fig.1
Ripple rejection ratio 1	R.R1	—	55	—	dB	I _{o1} =500mA, f=120Hz e _{IN} =1V _{rms}	Fig.2
Input stability 1	Reg.I1	—	50	100	mV	V _{cc} =11→25V, I _o =500mA	Fig.1
Load regulation 1	Reg.L1	—	100	150	mV	I _o =5mA→1A	Fig.1
Output short-circuit current 1	I _{OS1}	—	150	—	mA	V _{cc} =25V	Fig.5
〈5V output section〉							
Output voltage 2	V _{O2}	4.75	5.0	5.25	V	I _{o2} =350mA	Fig.1
Minimum I/O voltage differential 2	ΔV _{O2}	—	0.3	0.5	V	I _{o2} =350mA V _{cc} =0.95V _{O2}	Fig.3
Output current capacity 2	I _{o2}	500	—	—	mA		Fig.1
Ripple rejection ratio 2	R.R2	—	60	—	dB	I _{o2} =350mA, f=120Hz e _{IN} =1V _{rms}	Fig.2
Input stability 2	Reg.I2	—	50	100	mV	V _{cc} =6→25V, I _o =350mA	Fig.1
Load regulation 2	Reg.L2	—	50	100	mV	I _o =5mA→500mA	Fig.1
Output short-circuit current 2	I _{OS2}	—	100	—	mA	V _{cc} =25V	Fig.5
〈Switch section〉							
OFF mode voltage	V _{TH1}	2.0	—	—	V	Output ACTIVE mode	Fig.6
ON mode voltage	V _{TH2}	—	—	0.8	V	Output OFF mode	Fig.6
Input high level current	I _{IN}	—	150	—	μA	V _{TH} =5V	—

©Not designed for radiation resistance.

Note: All the characteristic values are measured with a 0.33 μF-capacitor connected to the input pin and 22 μF-capacitor connected to the output pin.

Measurements are made by using a pulse all cases but noise voltage and the ripple rejection ratio.

● Measurement circuits

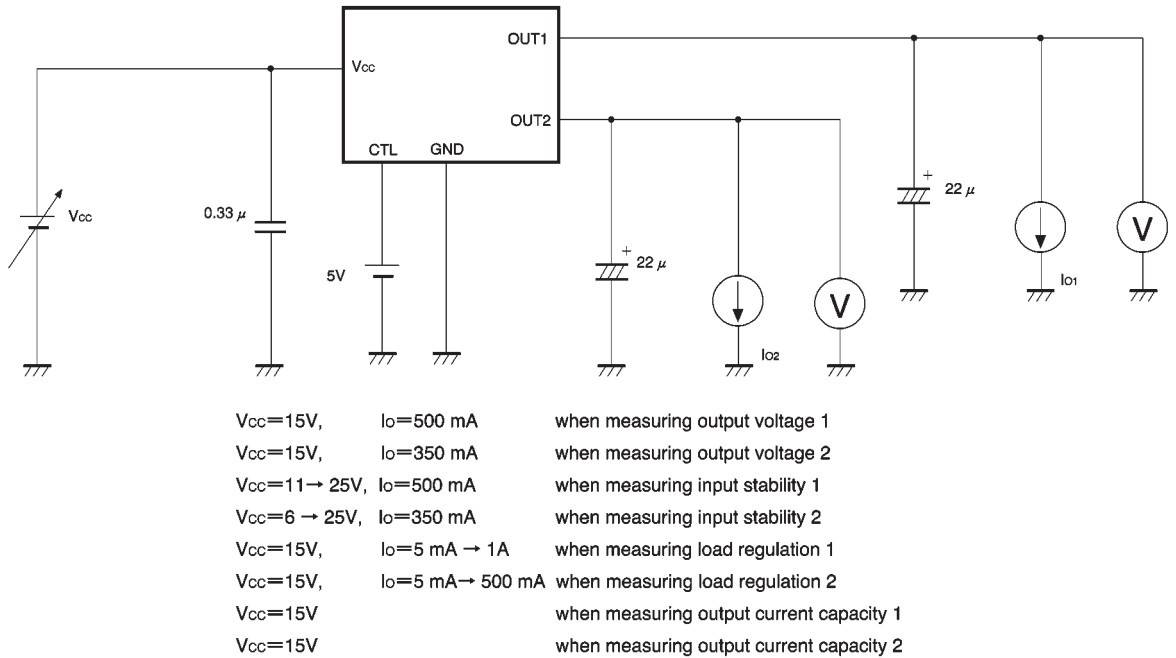

Fig.1 Circuit for measuring output voltage, input stability, load regulation, and output current capacity

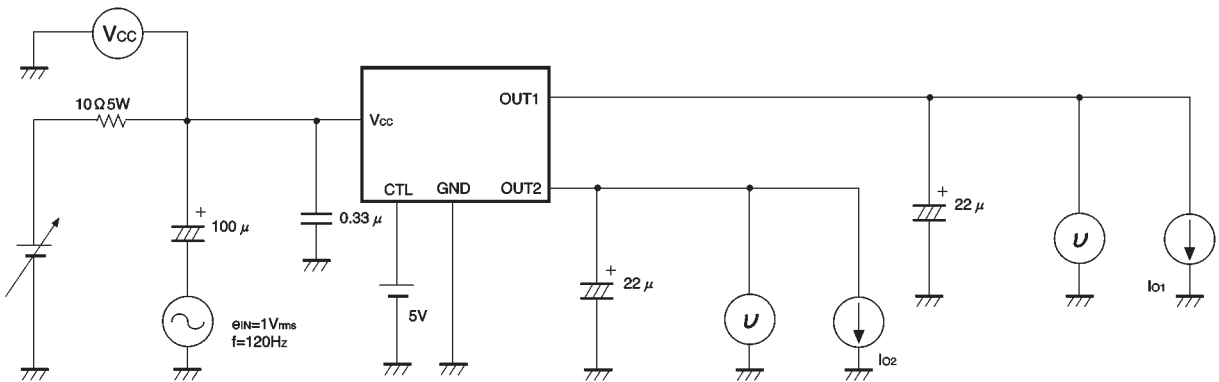

Fig.2 Circuit for measuring ripple rejection ratio

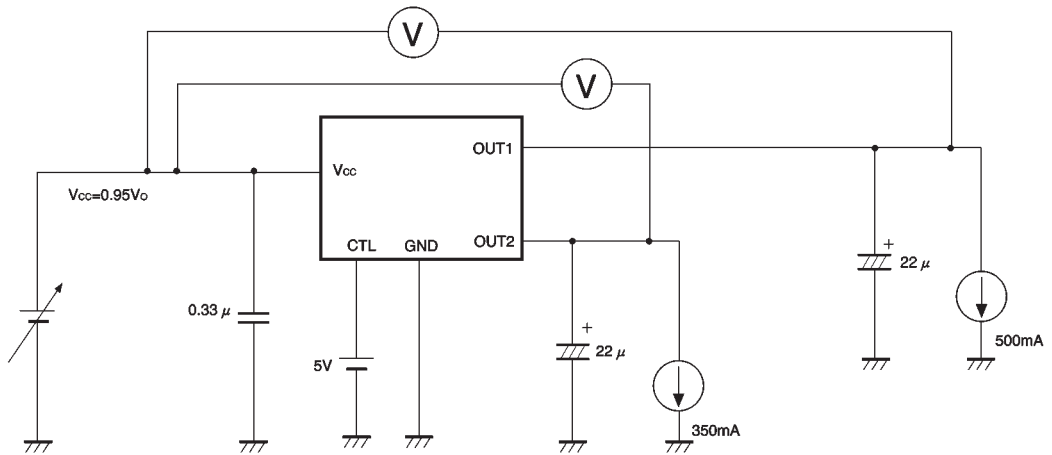
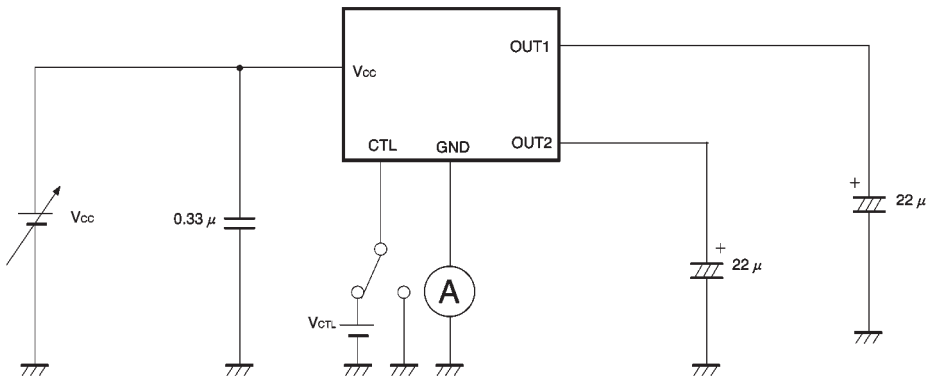

Fig.3 Circuit for measuring minimum I / O voltage differential



$V_{cc} = 15\text{ V}$, $I_o = 0\text{ mA}$, $V_{ctl} = 5\text{ V}$ when measuring bias current
 $V_{cc} = 15\text{ V}$, $I_o = 0\text{ mA}$, $V_{ctl} = 5\text{ V}$ when power save supply current

Fig.4 Circuit for measuring bias current power save supply current

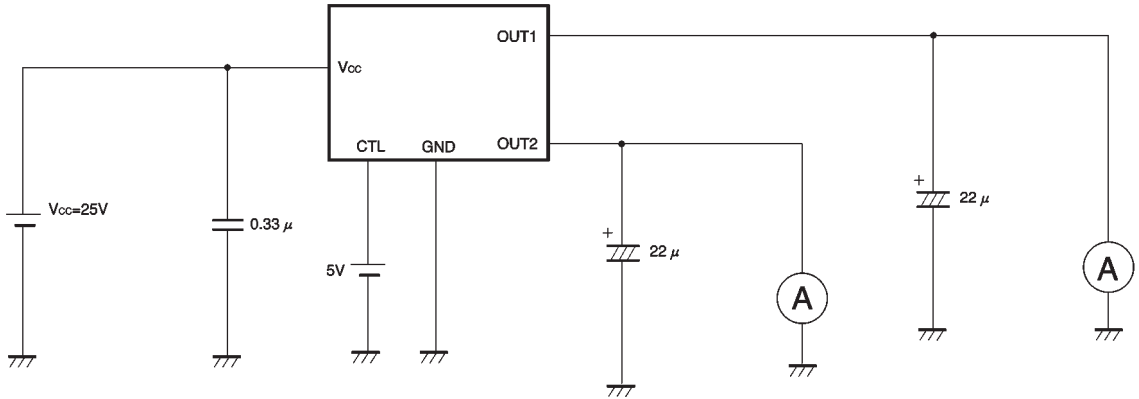

Fig.5 Circuit for measuring output short-circuit current

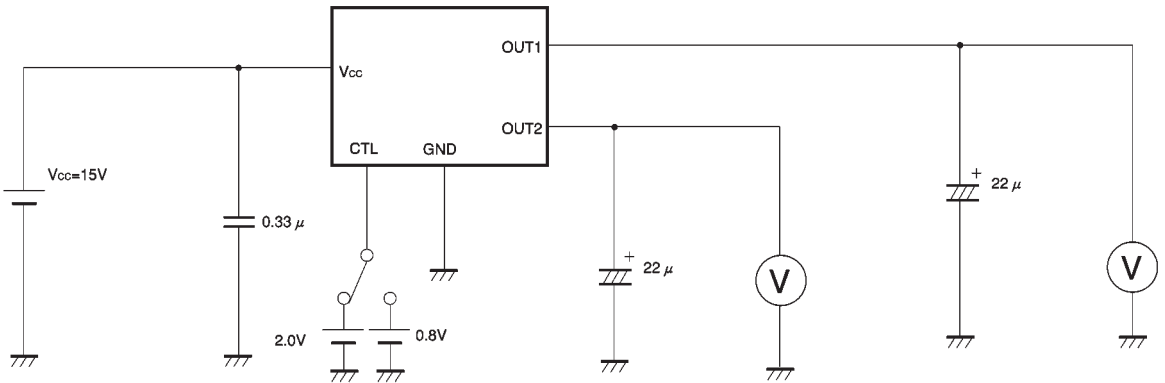

Fig.6 Circuit for measuring mode switching voltage

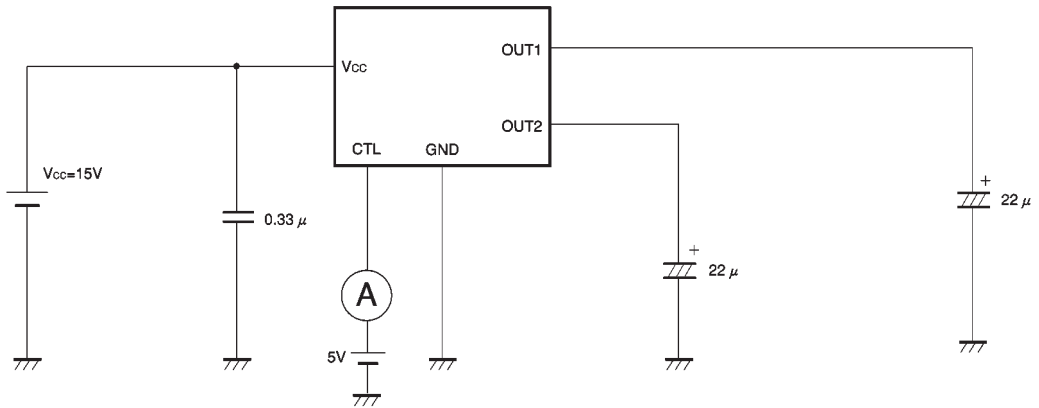

Fig.7 Circuit for measuring input high level current

●Application example

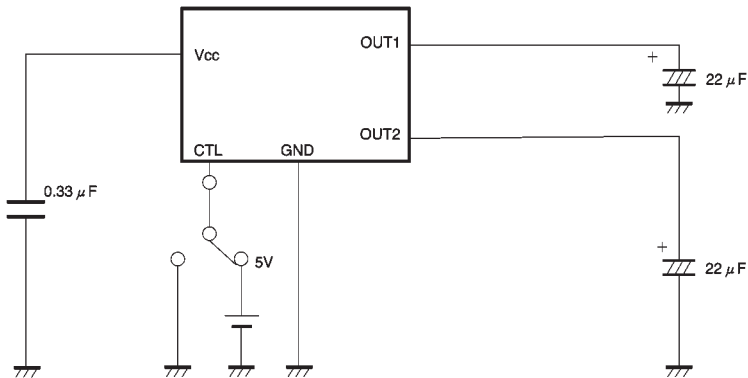

Fig.8

● Operation notes

(1) The application circuit of Fig.8 is recommended for use. Make sure to confirm the adequacy of parts characteristics. When using the circuit with changes to external circuit constants, make sure to leave sufficient margins in consideration of fluctuations in the IC and external components including static and transitional characteristics. Note that ROHM has not carried out extensive survey regarding the patent right of this application.

(2) Operating power supply voltage

When operating within the proper ranges of power supply voltage and ambient temperature, most circuit functions are guaranteed. Although the rated values of electrical characteristics cannot be absolutely guaranteed, characteristic values do not change drastically within the proper ranges.

(3) Power dissipation (Pd)

Refer to the power dissipation characteristics in Fig. 10. If power dissipation exceeds the allowable limit, the functionality of the IC will be degraded (such as reduction of current capacity by increased chip temperature). Make sure to use the IC within the allowable range of power dissipation with a sufficient margin.

(4) Preventing oscillation at each output and bypass capacitor

To stop output oscillation, make sure to connect a capacitor between GND and each output pin (capacitance of at least 10 μ F over the whole operating temperature range is recommended). Oscillation can occur if capacitance is susceptible to temperature. We recommend using a tantalum electrolytic capacitor with minimal changes in capacitance. Also, output can be further stabilized by connecting a bypass capacitor of about 0.33 μ F between the input pin and GND. Place the capacitor as near as possible to the input pin.

(5) Overcurrent protection circuit

An overcurrent protection circuit is installed in each output system, based on the respective output current. This prevents IC destruction due to overcurrent, by limiting the current with a curve shape of "7" in the voltage-current graph. The IC is designed with margins so that current flow will be restricted and latching will be prevented even if a large current suddenly flows through a large capacitor. Note that these protection circuits are only good for preventing damage from sudden accidents. Make sure your design does not cause the protection circuit to operate continuously under transitional conditions (for instance, if output is clamped at 1Vf or higher, short mode circuit operates at 1Vf or lower). Note that the circuit ability is negatively correlated with temperature.

(6) Thermal protection circuit

A built-in thermal protection circuit prevents thermal damage to the IC. All outputs are turned off when the circuit operates, and revert to the original state when the temperature drops to a certain level.

(7) We recommend installing a bypass line with a diode in your application if there is a mode where potential difference between each output and input (V_{CC}) or GND is reversed from the normal state. A reversed mode may cause damage to the IC.

(8) Although the quality of this IC is rigorously controlled, the IC may be destroyed when the applied voltage or the operating temperature exceeds its absolute maximum rating. Because short mode or open mode cannot be specified when the IC is destroyed, be sure to take physical safety measures, such as fusing, if any of the absolute maximum ratings might be exceeded.

(9) When used within a strong magnetic field, be aware that there is a slight possibility of malfunction.

●Electrical characteristic curves

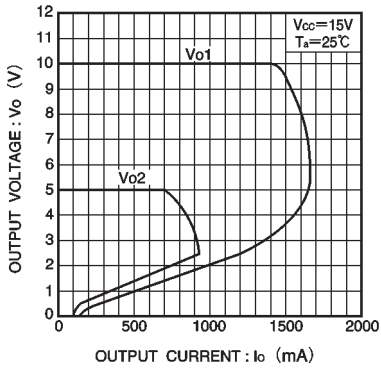

Fig.9 Output current capacity characteristics (Typ.)

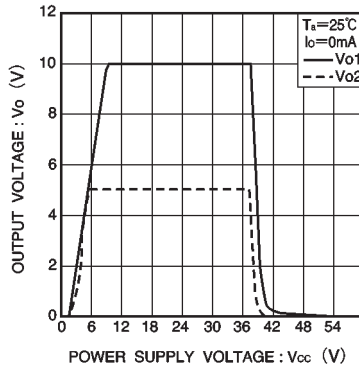

Fig.10 Output voltage characteristic (Typ.)

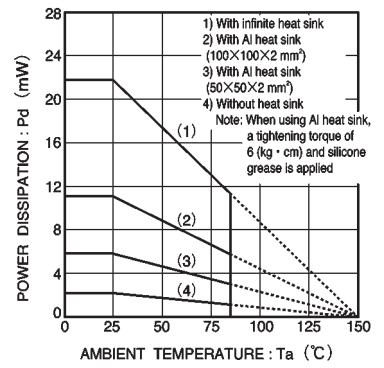
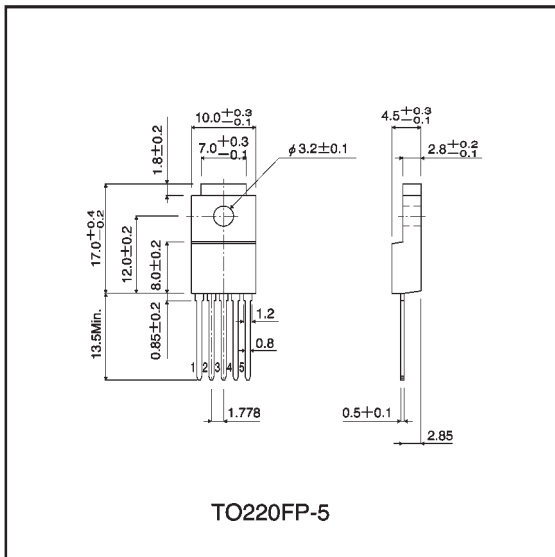

Fig.11 Thermal derating characteristics

●External dimensions (Units: mm)



This datasheet has been downloaded from:

www.DatasheetCatalog.com

Datasheets for electronic components.



LittleDiode supplies new, hard to find or obsolete electronic components and semiconductors all over the world.

With over two million different components listed you are sure to find the part you need.

Feel free to visit us today at our online store:

LittleDiode.com

Looking forward to providing you with the best possible service.