

2-channel BTL driver for CDplayers

BA6295AFP

The BA6295AFP is a 2-channel BTL driver for CD player actuators and motors. This IC delivers a large output current and is ideal for car CD players.

● Applications

CD players

● Features

- 1) 2-channel BTL driver.
- 2) High output current. ($I_o = I_A$ Typ.)
- 3) HSOP 28-pin package allows for miniaturization of applications.
- 4) Internal thermal shutdown.
- 5) Gain is adjustable by inserting a resistor between pins 27 and 28 ; pins 18 and 16.

● Block diagram

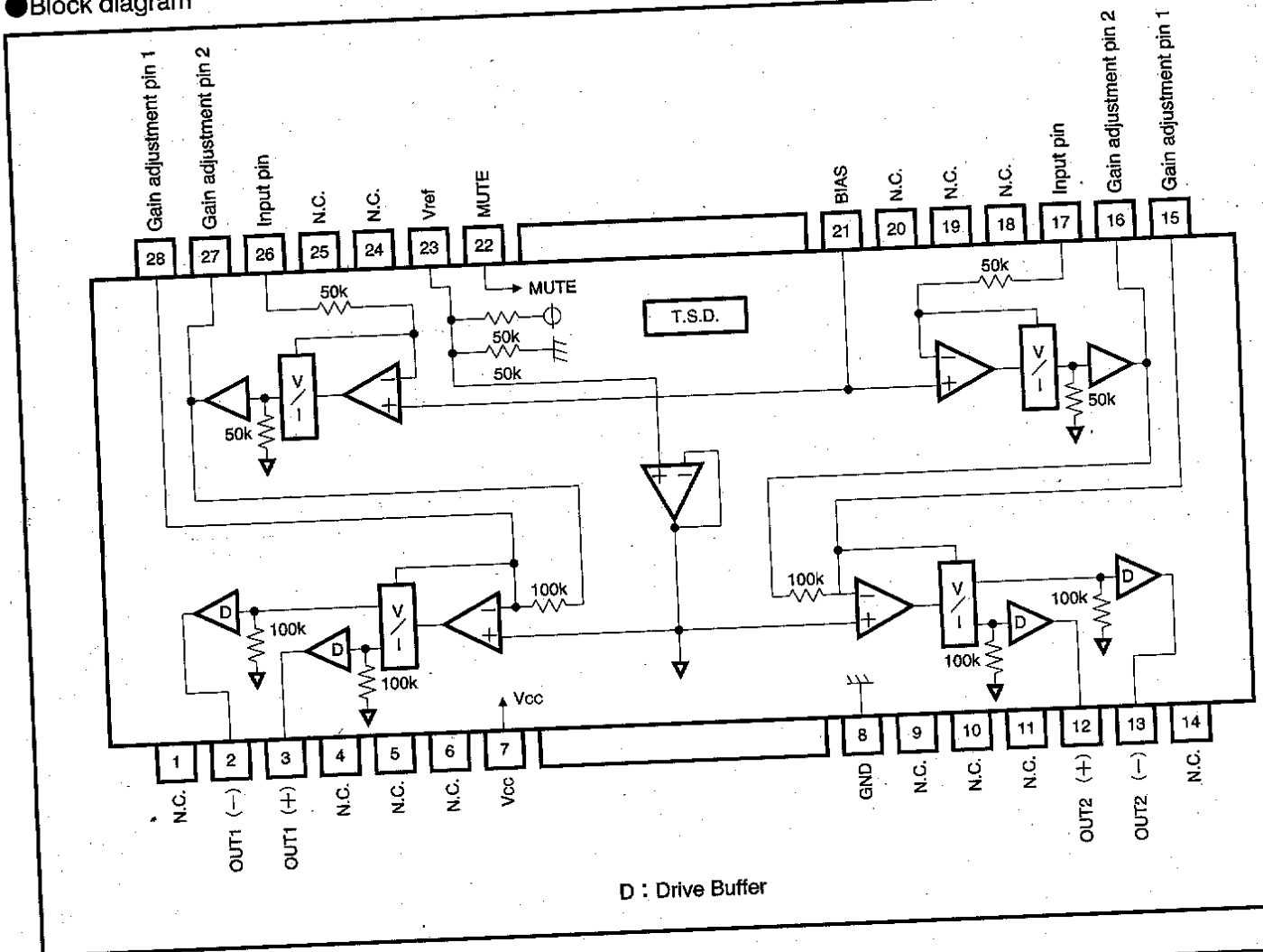

●Absolute maximum ratings (Ta=25°C)

Parameter	Symbol	Limits	Unit
Power supply voltage	V _{CC}	22	V
Power dissipation	P _d	1.7*	W
Operating temperature	T _{opr}	-30~85	°C
Storage temperature	T _{stg}	-55~150	°C

*Reduced by 13.6 mW for each increase in Ta of 1°C over 25°C.
When mounted to a 50 × 50 × 1.0 mm paper phenol board

●Recommended operating conditions (Ta=25°C)

Parameter	Symbol	Min.	Typ.	Max.	Unit
Operating power supply voltage	V _{CC}	7.5	—	18*	V

*Set the power supply voltage according to power dissipation.

●Electrical characteristics (Unless otherwise noted, Ta=25°C, V_{CC}=10V, f=1kHz)

Parameter	Symbol	Min.	Typ.	Max.	Unit	Conditions	Measurement Circuit
Quiescent current	I _{CC}	3.4	5.2	7	mA	No load	Fig.5
Output offset voltage	V _{OO}	-30	0	30	mV		Fig.5
Maximum output current 1	I _{OSO}	1	—	—	A	GND output at R _L = 4 Ω	Fig.5
Maximum output current 2	I _{OSI}	1	—	—	A	V _{CC} output at R _L = 4 Ω	Fig.5
Maximum output amplitude	V _{OM}	3.2	3.6	—	V _{rms}	V _{in} =2V _{rms} , 1kHz	Fig.5
Closed loop voltage gain	G _{VC}	—	5.0	—	dB	V _{in} =1V _{rms} , 1kHz	Fig.5
Cutoff frequency	f _c	—	40	—	kHz	V _{in} =1V _{rms} , 3dB DOWN	Fig.5
Crosstalk	CT	60	80	—	dB	V _{in} =1V _{rms} , 1kHz,	Fig.5
Ripple rejection	RR	50	70	—	dB	V _{in} =0.1V _{rms} , 100Hz	Fig.5
Slew rate	SR	—	0.5	—	V/μs	V _{in} =1V _{P-P}	Fig.5
Bias pin voltage	V _{BI}	—	5.0	—	V		Fig.5

†Not designed for radiation resistance.

●Electrical characteristic curves

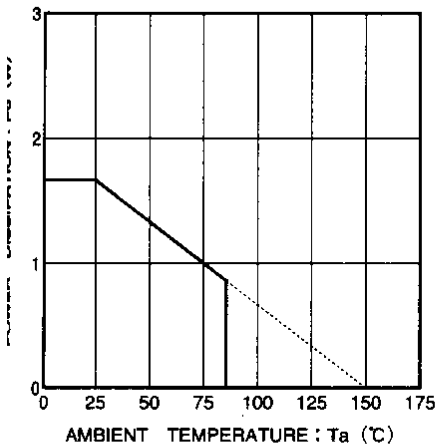

Fig. 1 Thermal derating curve

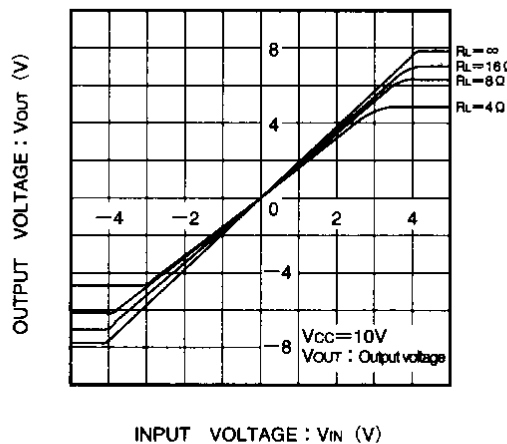

Fig. 2 I/O characteristics (variable load)

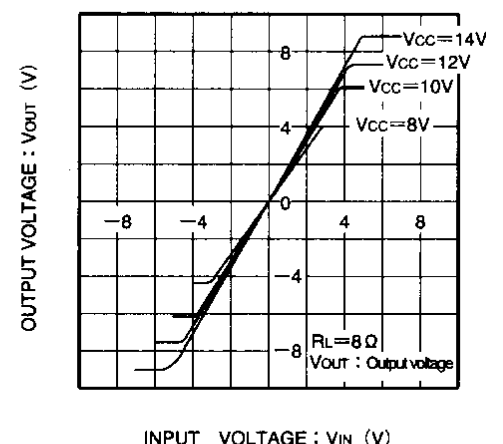

Fig. 3 I/O characteristics (variable supply voltage)