

Fan motor driver IC

BA6811F / BA6813F

The BA6811F and BA6813F are 2-phase, half-wave motor drivers suited for 12V fan motors. Built-in lock detection and automatic restart mechanisms protect motors. Compact SOP8 (BA6811F/BA6813F) packages reduce the number of external components required.

●Applications

2-phase fan motors

●Features

- 1) Built-in power transistors.
- 2) Lock detection and automatic restart mechanisms.
- 3) Built-in thermal shutdown circuit.
- 4) Alarm output pin. (BA6811F)
- 5) Hall signal output pin. (BA6813F)
- 6) Built-in reverse current protection diode.

●Absolute maximum ratings (Ta = 25°C)

Parameter	Symbol	Limits	Unit
Power supply voltage	V _{CC}	18	V
Power dissipation	P _d	550*1	mW
Operating temperature	T _{opr}	-25~+85	°C
Storage temperature	T _{stg}	-55~+150	°C
Output current	I _{OUT}	1.0*2	A
Alarm output pin current *3	I _{AL}	10	mA
Alarm output pin withstanding voltage *3	V _{AL}	36	V
Hall signal output pin current *4	I _{HO}	10	mA
Hall signal output pin withstanding voltage *4	V _{HO}	36	V

*1 Reduced by 4.4 mW for each increase in Ta of 1°C over 25°C.
When mounted on a glass epoxy board (50.0×50.0×1.6 mm).

*2 Should not exceed P_d or ASO values.

*3 BA6811F only.

*4 BA6813F only.

●Recommended operating conditions (Ta = 25°C)

Parameter	Symbol	Limits	Unit
Operating power supply voltage	V _{CC}	4.0~15.0	V

● Block diagram

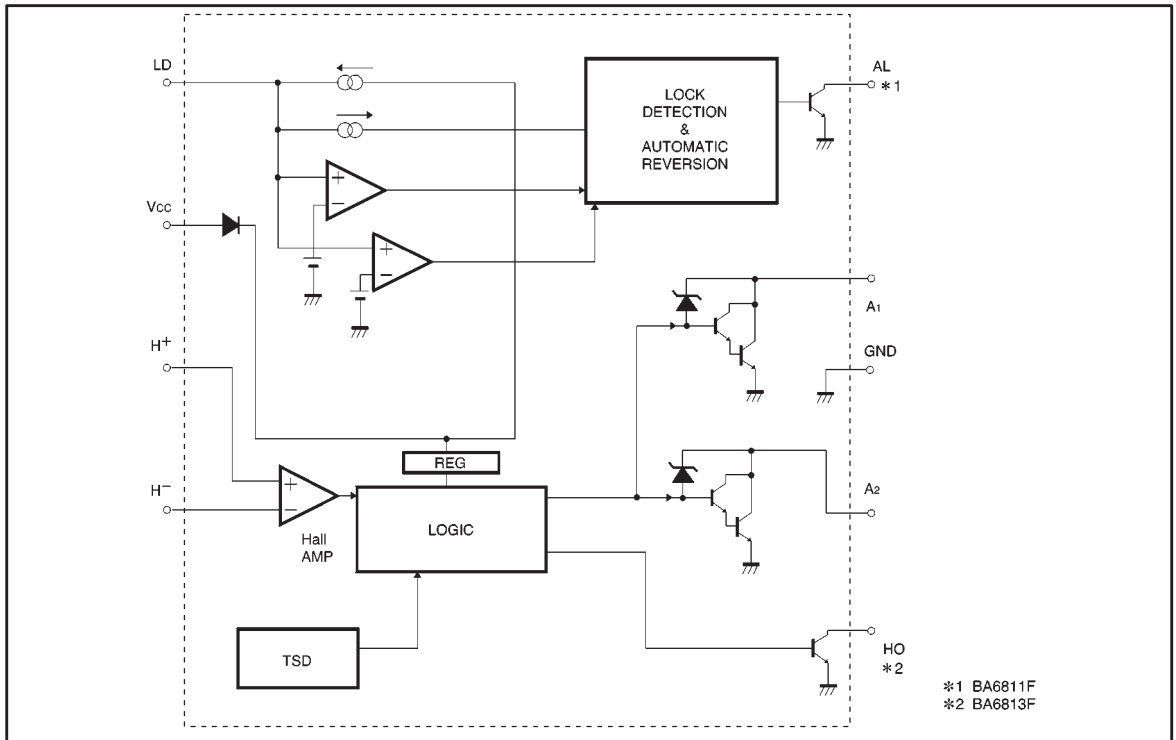

● Pin descriptions

BA6811F

Pin No.	Pin name	Function
1	A ₂	Output 2
2	AL	Alarm output
3	LD	Capacitor connection pin for lock detection and automatic restart
4	V _{CC}	Power supply
5	H ⁺	Hall input (+)
6	H ⁻	Hall input (-)
7	A ₁	Output 1
8	GND	GROUND

BA6813F

Pin No.	Pin name	Function
1	A ₂	Output 2
2	HO	Hall signal output
3	LD	Capacitor connection pin for lock detection and automatic restart
4	V _{CC}	Power supply
5	H ⁺	Hall input (+)
6	H ⁻	Hall input (-)
7	A ₁	Output 1
8	GND	GROUND

● Hall input / output truth table

H ⁺	H ⁻	A ₁	A ₂	HO
H	L	HIGH (output transistor OFF)	LOW (output transistor ON)	LOW (output transistor ON)
L	H	LOW (output transistor ON)	HIGH (output transistor OFF)	HIGH (output transistor OFF)

Note: LD = 0 V

● Input / output equivalent circuits

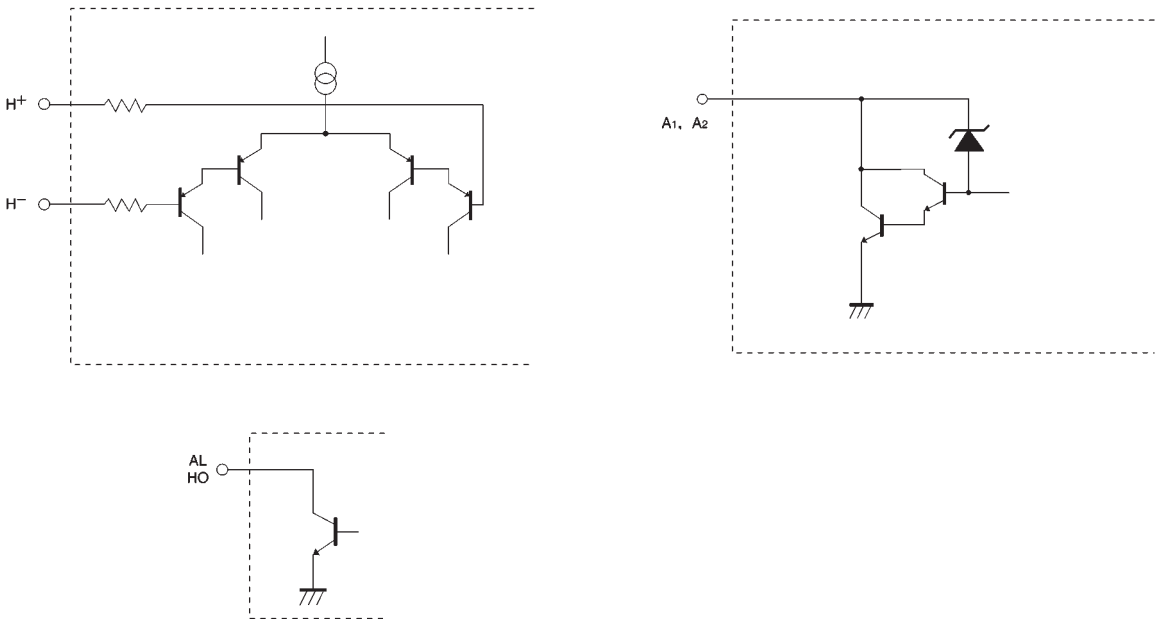

● Electrical characteristics (unless otherwise noted, Ta = 25°C, Vcc = 12V)

Parameter	Symbol	Min.	Typ.	Max.	Unit	Conditions
Supply current	I _{CC}	1.8	4.5	9.0	mA	When output is OFF
Lock detection capacitor charge current	I _{LDC}	1.6	2.9	4.64	μA	V _{LD} =1.2V
Lock detection capacitor discharge current	I _{LDD}	0.26	0.52	0.87	μA	V _{LD} =1.2V
Lock detection capacitor charge/discharge ratio	r _{CD}	2.8	5.7	9.9	—	r _{CD} =I _{LDC} / I _{LDD}
Lock detection capacitor clamp voltage	V _{LDCL}	1.27	1.93	2.60	V	
Lock detection capacitor comparator voltage	V _{LDOP}	0.47	0.76	1.06	V	
Output low level voltage	V _{OL}	—	0.8	1.3	V	I _o =200mA
Output leakage current	I _{oL}	—	—	100	μA	V _o =20V
Output zener voltage	V _{OZ}	28	30	32	V	Clamp current = 10 mA
Alarm output pin low level voltage *1	V _{ALL}	—	0.13	0.5	V	I _o =5mA
Alarm output pin leakage current *1	I _{ALL}	—	—	50	μA	V _{AL} =15V
Hall signal output pin voltage *2	V _{HOL}	—	0.13	0.5	V	I _o =5mA
Hall signal output pin leakage current *2	I _{HOL}	—	—	50	μA	V _{HO} =15V
Hall input pin offset voltage	V _{OFF}	—	—	10	mV	V _{COM} =6.0V

*1 BA6811F only

*2 BA6813F only

©Not designed for radiation resistance.

●Circuit operation

The BA6811F and BA6813F have motor lock detection and automatic restart circuits. The timing of lock detection and automatic restart is determined by the external capacitor connected to the LD pin. The charge time of the external capacitor is given by :

(Typical value)

$$T_{ON} \text{ (Charge time)} = \frac{C \cdot (V_{LDCL} - V_{LDCLP})}{I_{LDC}}$$

$$T_{OFF} \text{ (Discharge time)} = \frac{C \cdot (V_{LDCL} - V_{LDCLP})}{I_{LDD}}$$

where

- V_{LDCL} is the LD-pin clamp voltage (1.93V),
- V_{LDCLP} is the LD-pin comparator voltage (0.76V),
- I_{LDC} is the LD-pin charge current (2.9 μ A),
- I_{LDD} is the LD-pin discharge current (0.52 μ A),
- C is the capacitance of the LD-pin external capacitor.

For $C=1\mu$ F, for example, the charge (output ON) and discharge (output OFF) times are 0.40s and 2.25s, respectively.

The timing chart for an occasion of motor locking is shown in Fig. 1.

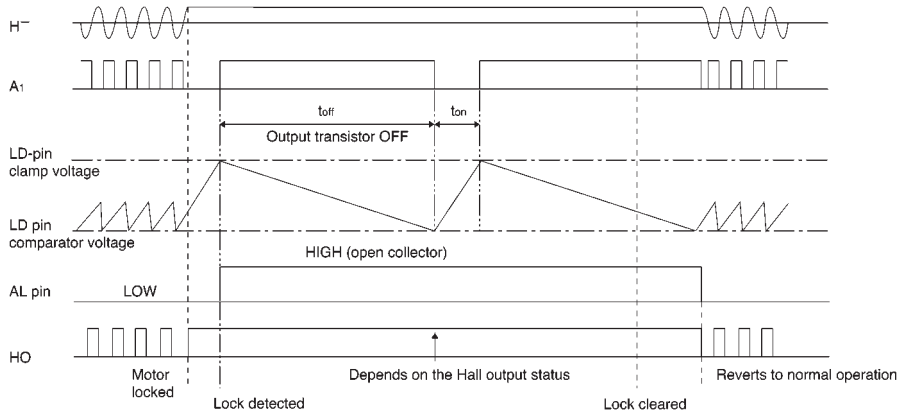

Fig.1 Timing chart for motor locking

●Application example

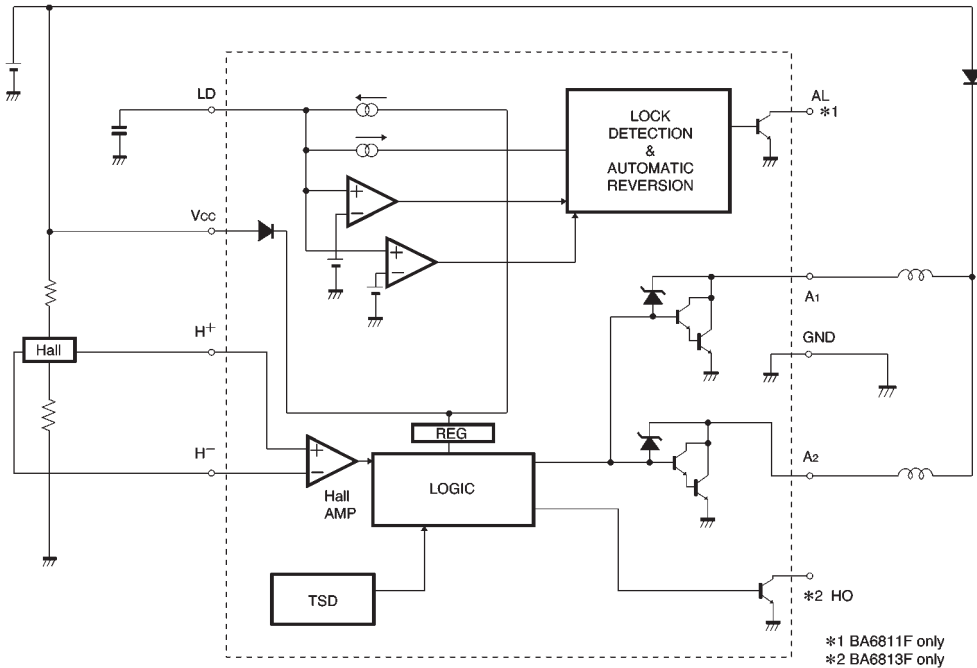

Fig.2

●Operation notes

(1) Thermal shutdown circuit

The IC has a built-in thermal shutdown circuit. This is a temperature difference of 25°C (typical) between the temperatures at which the circuit is activated and deactivated.

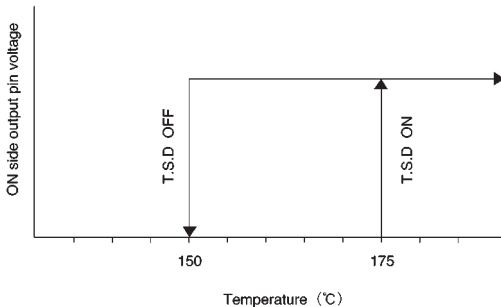

Fig.3 Temperature setting of the thermal shutdown circuit

The circuit is activated at the temperature of about 175°C (typical), so that all outputs are turned OFF. Normal operation resumes when the circuit is deactivated.

(2) Power consumption

Power consumed in the IC can be calculated from the following equation :

$$P_c = P_{c1} + P_{c2} + P_{c3}$$

P_{c1} is power consumed by the circuit current.

$$P_{c1} = V_{CC} \times I_{CC}$$

P_{c2} is the output current consumption.

$$P_{c2} = V_{OL} \times I_o$$

V_{OL} is the LOW level output voltage of output pins 1 and 2, and I_o is the sink current of pins 1 and 2.

P_{c3} is power consumed by the AL and HO pins.

$$P_{c3} = V_{ALL} \times I_{AL} + V_{HOL} \times I_{HO} / 2$$

where

V_{ALL} is the AL-pin LOW level voltage,

I_{AL} is the AL-pin sink current,

V_{HOL} is the HO-pin LOW level voltage,

I_{HO} is the HO-pin sink current.

Make sure that your application does not exceed the allowable power dissipation of the IC.

(3)Hall amplifier input voltage

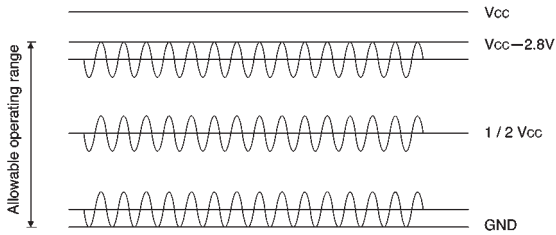

Fig.4 Hall amplifier input bias voltage

The R1 and R2 resistances must be set so as to maintain the Hall amplifier input bias voltage within the range of 0V to (V_{CC} – 2.8V) including the signal amplitude.

The Hall device may be affected by power supply noise due to the PCB conductor pattern. If you have this problem, insert a capacitor C1 as shown in Fig. 5.

If the conductor lines from the Hall device output terminals to the Hall inputs of the IC are particularly long, noise can be picked up and fed into the inputs. If you have this problem, insert a capacitor C2 as shown in Fig. 5. Note that the Hall inputs have no hysteresis in this IC.

$$\text{Hall current is given by : } \frac{V_{CC}}{R1 + R2 + R_H}$$

where R_H is the Hall device impedance.

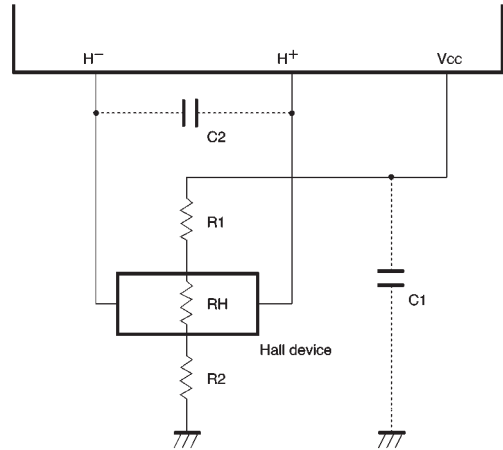
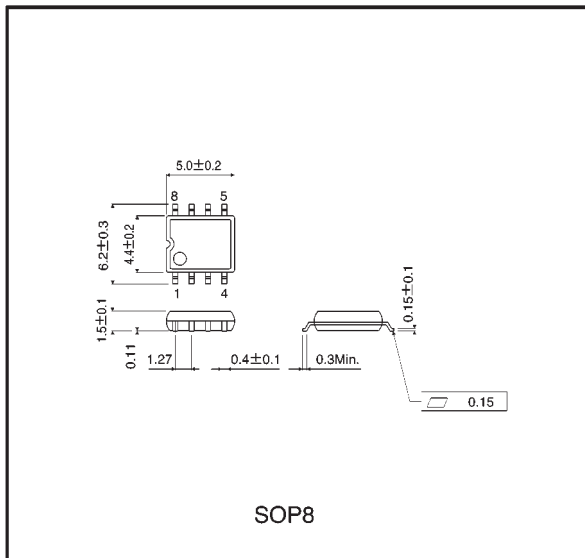

Fig.5

●External dimensions (Units: mm)





LittleDiode supplies new, hard to find or obsolete electronic components and semiconductors all over the world.

With over two million different components listed you are sure to find the part you need.

Feel free to visit us today at our online store:

LittleDiode.com

Looking forward to providing you with the best possible service.