

3-phase motor driver for CD-ROMs

BA6848FP / BA6853FS

The BA6848FP and BA6853FS are single-chip ICs developed for CD-ROM spindle motor drives. These ICs are 3-phase, full-wave, pseudo-linear drives with FG output, FG composite output, and reverse-rotation pins built-in for high functionality and high performance.

●Applications

CD-ROM, CD-R, CD-RW, DVD-ROM, DVD-RAM

●Features

- 1) Three-phase, full wave, pseudo-linear drive system.
- 2) Built-in PS pin for power save mode when ON.
- 3) Built-in thermal shutdown and current limiter circuits.
- 4) Built-in Hall bias circuit (for the BA6848FP).
- 5) Built-in FG output and FG composite output.
- 6) Built-in reverse-rotation pin.

●Absolute maximum ratings (Ta = 25°C)

Parameter		Symbol	Limits	Unit
Applied voltage		V _{CC}	7	V
Applied voltage		V _{M1,2}	16	V
Power dissipation	BA6848FP	Pd	1700*1	mW
	BA6853FS		1000*2	
Operating temperature		T _{opr}	-20~+75	°C
Storage temperature		T _{stg}	-55~+150*4	°C
Output current		I _{OUT}	1300*3	mW

*1 When mounted on a 90mm×50mm×1.6 mm glass epoxy board.

Reduced by 13.6mW for each increase in Ta of 1°C over 25°C.

*2 Reduced by 8.0mW for each increase in Ta of 1°C over 25°C.

*3 Should not exceed Pd and ASO values.

*4 Ta should not exceed 150°C.

●Recommended operating conditions (Ta = 25°C)

Parameter	Symbol	Limits	Unit
Operating power supply voltage	V _{CC}	4.25~5.5	V
	V _{M1}	3.0~15	V
	V _{M2}	3.0~15	V

●Block diagram

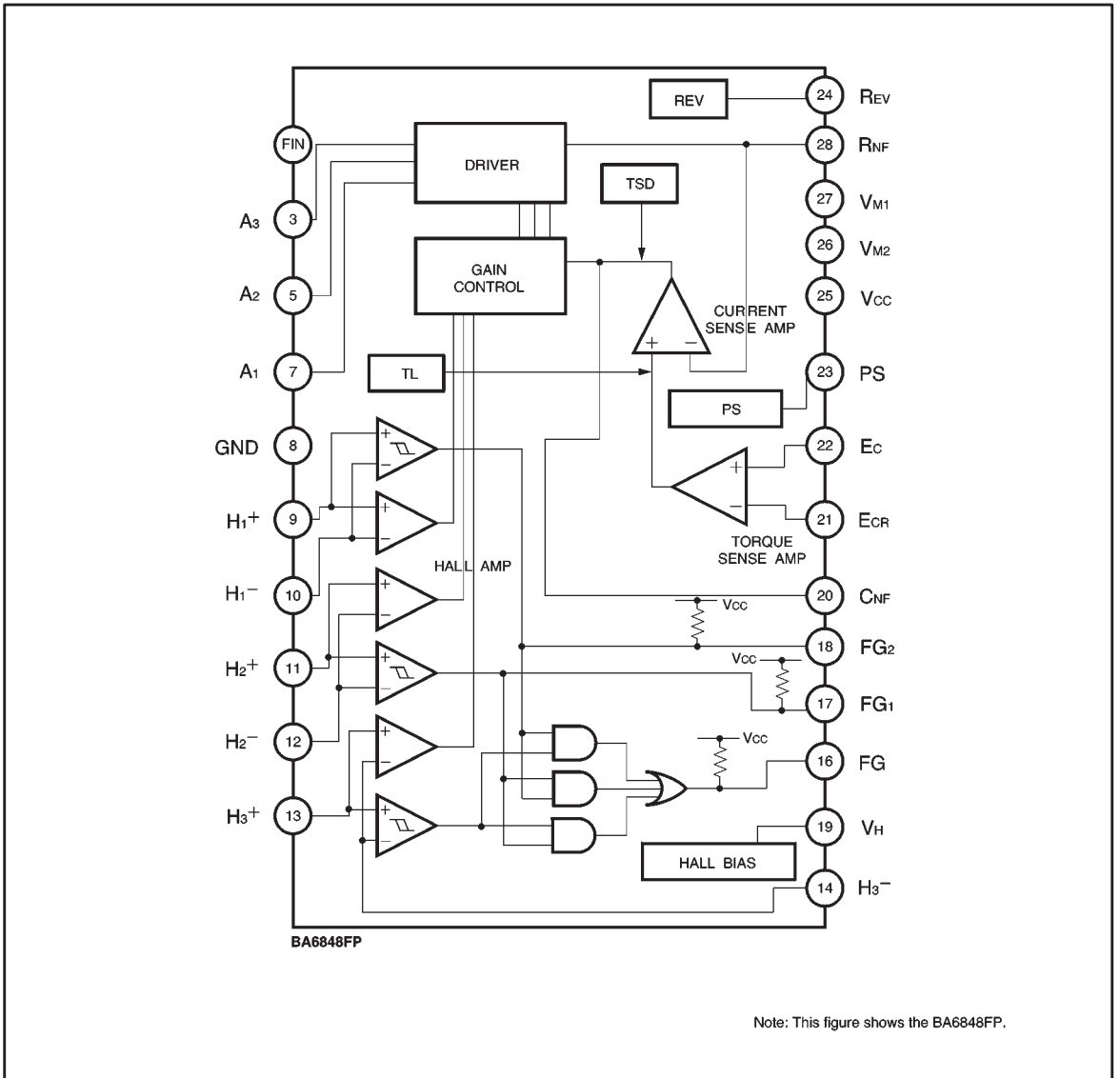

Note: This figure shows the BA6848FP.

● Pin descriptions

BA6848FP

Pin No.	Pin name	Function
1	N.C.	N.C.
2	N.C.	N.C.
3	A ₃	Output
4	N.C.	N.C.
5	A ₂	Output
6	N.C.	N.C.
7	A ₁	Output
8	GND	Ground
9	H ₁ ⁺	Hall signal input
10	H ₁ ⁻	Hall signal input
11	H ₂ ⁺	Hall signal input
12	H ₂ ⁻	Hall signal input
13	H ₃ ⁺	Hall signal input
14	H ₃ ⁻	Hall signal input
15	N.C.	N.C.
16	FG	Three-phase composite FG signal output
17	FG ₂	FG signal output
18	FG ₁	FG signal output
19	V _H	Hall bias
20	C _{NF}	For capacitor for phase compensation
21	E _{CR}	Torque control reference
22	E _C	Torque control
23	PS	Power save
24	R _{EV}	Reverse rotation
25	V _{CC}	Power supply
26	V _{M2}	Motor power supply
27	V _{M1}	12V power supply
28	R _{NF}	For resistor for output current detection
FIN	FIN	SUB GND

BA6853FS

Pin No.	Pin name	Function
1	GND	SUB GND
2	FG	Three-phase composite FG signal output
3	FG ₂	FG signal output
4	FG ₁	FG signal output
5	C _{NF}	For capacitor for phase compensation
6	E _{CR}	Torque control reference
7	E _C	Torque control
8	PS	Power save
9	R _{EV}	Reverse rotation
10	V _{CC}	Power supply
11	V _{M2}	Motor power supply
12	V _{M1}	12V power supply
13	R _{NF}	For resistor for output current detection
15	A ₃	Output
16	A ₂	Output
17	A ₁	Output
18	GND	Ground
19	H ₁ ⁺	Hall signal input
20	H ₁ ⁻	Hall signal input
21	H ₂ ⁺	Hall signal input
22	H ₂ ⁻	Hall signal input
23	H ₃ ⁺	Hall signal input
24	H ₃ ⁻	Hall signal input

● / ○ circuit diagrams

(1) Power save(PS)

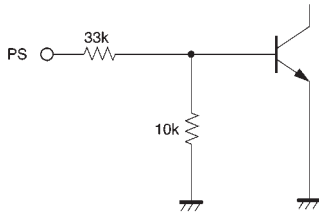

Fig.1

(2) Reverse (REV)

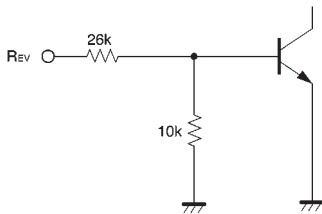

Fig.2

(3) Torque command input

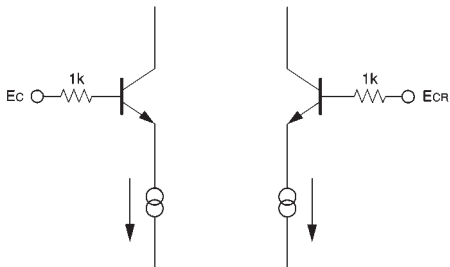

Fig.3

(4) Coil output (A₁, A₂, A₃)

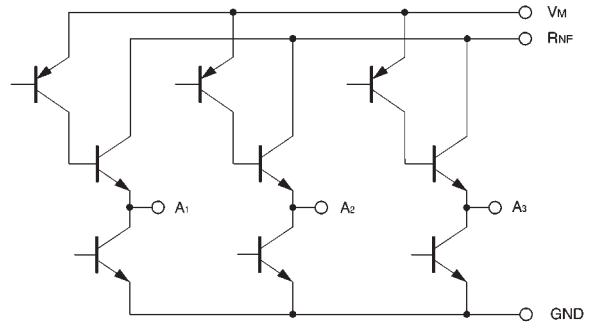

Fig.4

(5) Hall input

(H₁⁺, H₁⁻, H₂⁺, H₂⁻, H₃⁺, and H₃⁻)

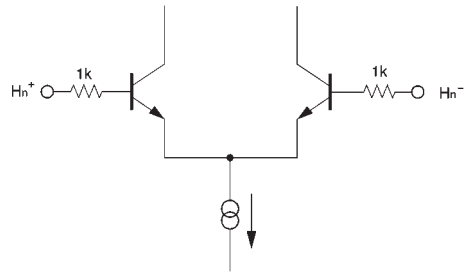

Fig.5

(6) Hall bias

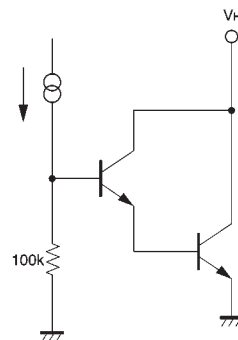

Fig.6 (for BA6848FP only)

Note: Resistances are typical values.

●Electrical characteristics (unless otherwise noted, Ta = 25°C, V_{CC} = 5V, V_{M1} = 12V, V_{M2} = 12V)

Parameter	Symbol	Min.	Typ.	Max.	Unit	Conditions
〈Total〉						
Circuit current 1	I _{CC1}	—	0	0.2	mA	With power save ON
Circuit current 2	I _{CC2}	—	5.2	7.6	mA	With power save OFF
〈Power save〉						
ON voltage	V _{PSON}	—	—	1.5	V	—
OFF voltage	V _{PSOFF}	3.5	—	—	V	—
〈Hall bias〉						
Hall bias voltage	V _{HB}	0.5	0.9	1.5	V	I _{HB} =10mA
〈Hall amplifier〉						
Input bias current	I _{HA}	—	0.7	3.0	μA	—
Common-phase input voltage	V _{HAR}	1.5	—	4.0	V	—
Minimum input level	V _{INH}	50	—	—	mV _{P-P}	—
H ₃ hysteresis level	V _{HYS}	10	20	40	mV	—
〈Torque command〉						
Input voltage	E _C , E _{CR}	1.0	—	4.0	V	—
Offset voltage (+)	E _{COFF+}	−80	−50	−20	mV	E _{CR} =2.5V
Offset voltage (−)	E _{COFF−}	20	50	80	mV	E _{CR} =2.5V
Input bias current	E _{CIN}	—	0.5	2.0	μA	E _C =E _{CR} =2.5V
I / O gain	G _{EC}	0.41	0.51	0.61	A / V	E _C =1.5, 2.0V, 3.0, 3.5V R _{NF} =0.5Ω
〈FG〉						
FG output high level voltage	V _{FGH}	4.5	4.9	5.0	V	I _{FG} =−20μA
FG output low level voltage	V _{FGL}	0	0.25	0.4	V	I _{FG} =3mA
〈Output〉						
Output high level saturation voltage	V _{CH}	—	1.0	1.5	V	I _O =−600mA
Output low level saturation voltage	V _{CL}	—	0.4	0.8	V	I _O =600mA
V _M leakage current	I _{VML}	—	35	70	mA	E _C =5V output open
Output limit current	I _{TL}	560	700	840	mA	R _{NF} =0.5Ω
〈Reverse rotation〉						
ON voltage	V _{RSON}	4.0	—	—	V	—
OFF voltage	V _{RSOFF}	—	—	1.5	V	—

◎Not designed for radiation resistance.

● Circuit operation

(1) Hall input and output

The phase relationship between the Hall input signals and the output current and voltage is shown below in Fig.7. The input three-phase Hall signal is sent to the matrix section for waveform synthesis. This signal is input to the output driver and supplies the drive current to the motor coil.

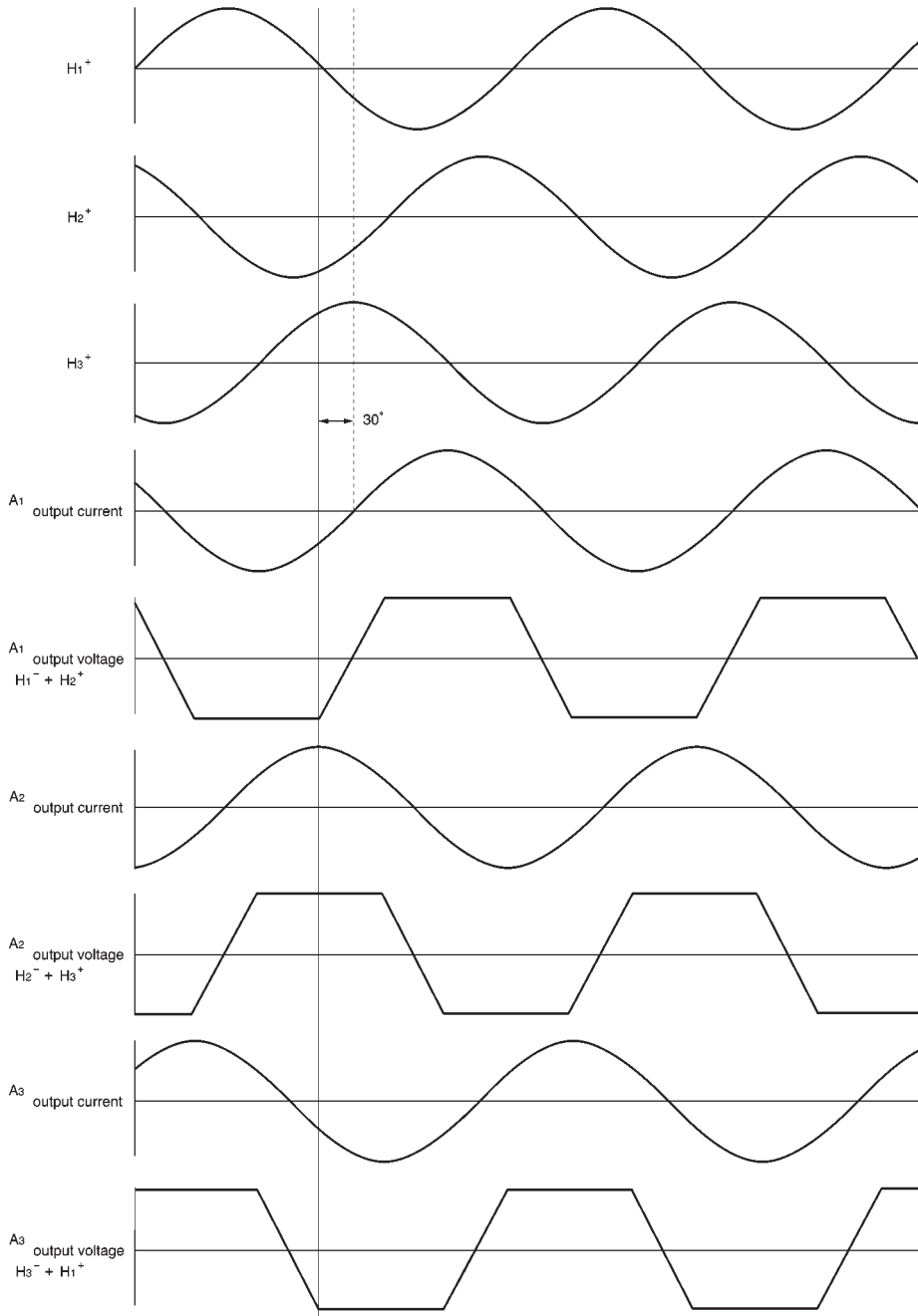

Fig.7

(2) Torque command

The R_{NF} pin voltage with respect to the torque command

(E_c) is as follows:

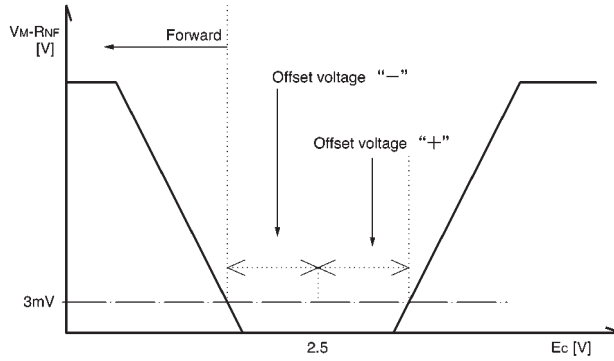

Fig.8

	Reverse rotation pin voltage	
	HIGH	LOW
$E_{CR} < E_c$	Forward rotation	Reverse rotation
$E_{CR} > E_c$	Stopped	Forward rotation

The I / O gain G_{EC} from E_c pin to R_{NF} pin (output current) is determined by the R_{NF} detector resistance.

$$G_{EC} = 0.255 / R_{NF} [A / V]$$

The torque limit current I_{TL} is:

$$I_{TL} = 0.35 / R_{NF} [A]$$

(3) FG signal output waveform

From the Hall input signal, a pulse signal (FG signal) is output proportional to the motor speed of rotation. This timing is shown in Fig.9 below.

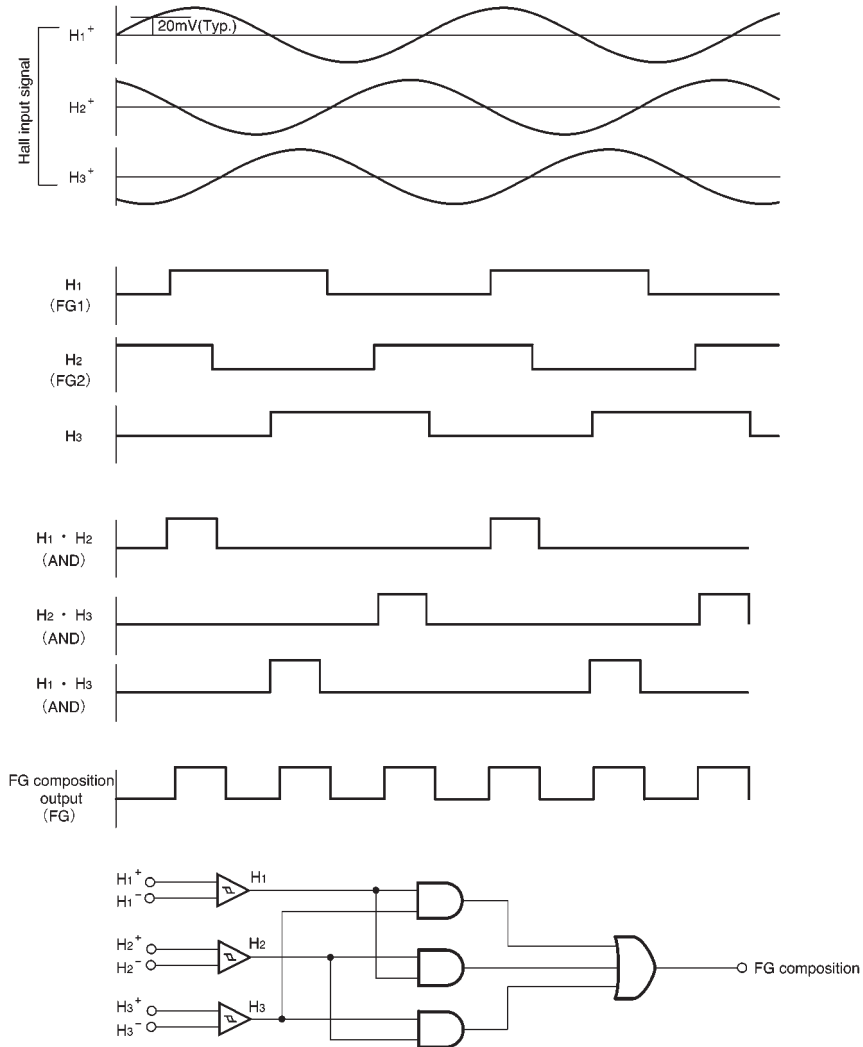
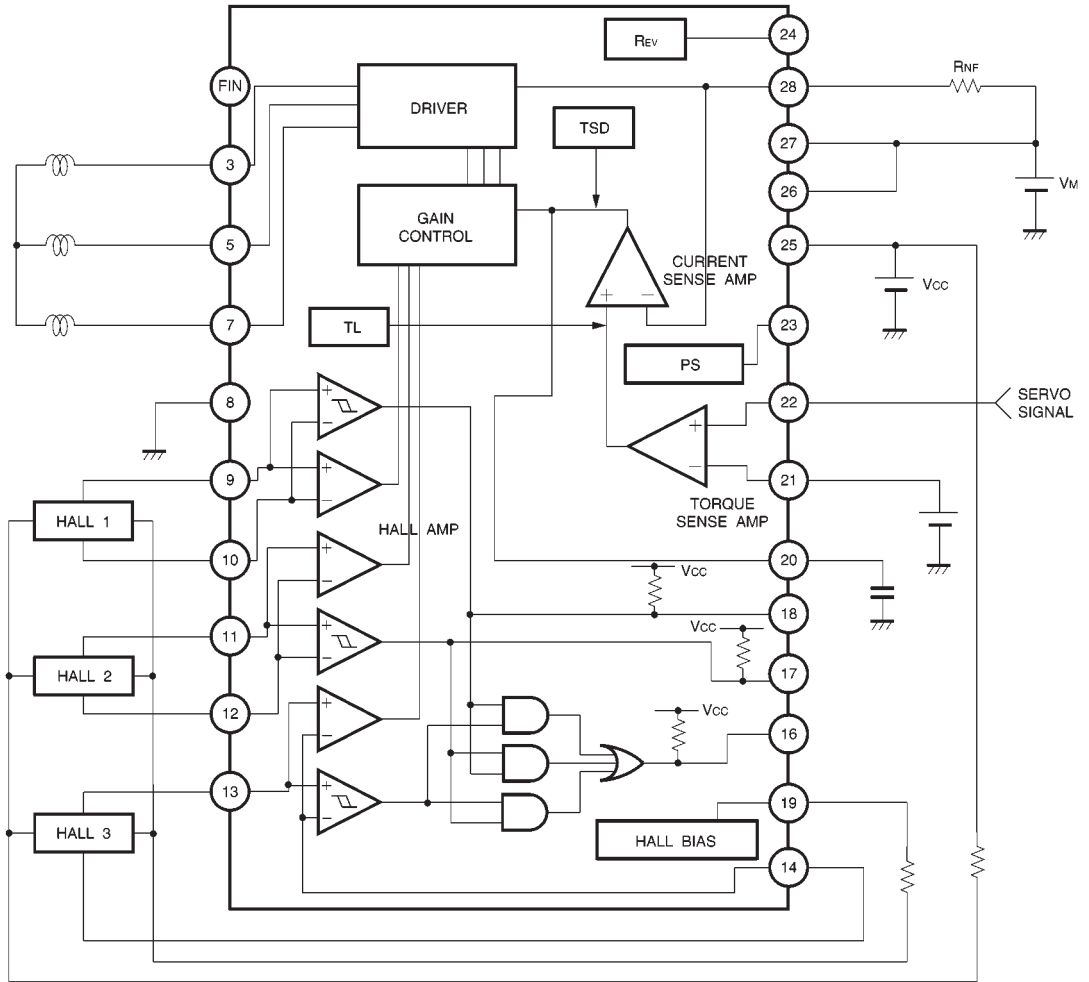

Fig.9

(4) Other

For the PS pins, the circuits turn on at 3.5 V or greater, and enter the power save mode at 1.5 V or less. For the R_{EV} pin, it enters the reverse mode at 4.0 V or greater, and enters the normal mode at 1.5 V or less.

●Application example



Note: This figure shows the BA6848FP.

Fig.10

● Operation notes

(1) Power save

The power save input is an input / output circuit as shown in Fig.1. The power save pins have a thermal derating characteristic of $-8\text{mV} / ^\circ\text{C}$. The resistance also has a fluctuation of $\pm 30\%$, so be careful of the input voltage range.

(2) Reverse

The reverse input is an input / output circuit as shown in Fig.2. The reverse pins have a thermal derating characteristic of $-7\text{mV} / ^\circ\text{C}$. The resistance also has a fluctuation of $\pm 30\%$, so be careful of the input voltage range.

(3) Hall input

The Hall input is an input circuit as shown in Fig.5. The Hall elements can be connected in series or in parallel.

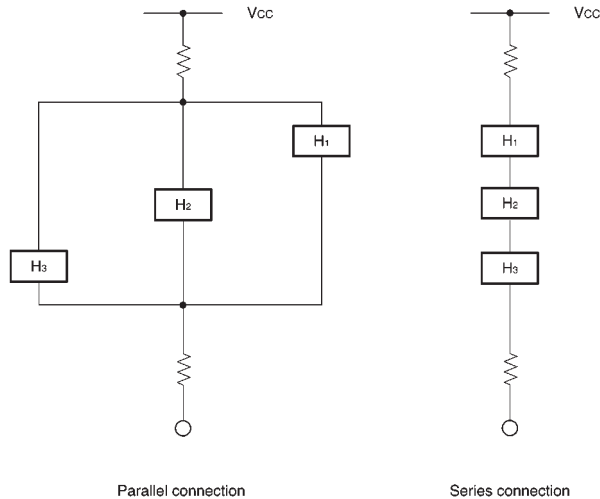

Fig.11

(4) Thermal shutdown (TSD)

When the junction temperature reaches 175°C (Typ.), the A_1 to A_3 coil outputs become open. There is an approximate 15°C (Typ.) temperature hysteresis.

●Electrical characteristic curves

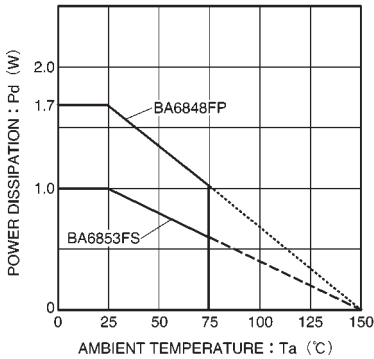

Fig.12 Package thermal derating characteristics

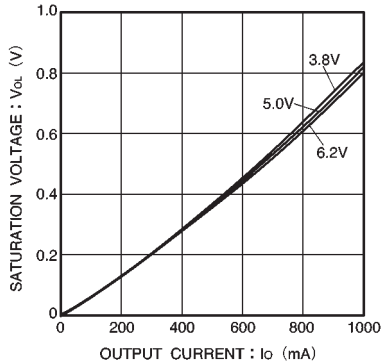

Fig.13 Low level output saturation voltage vs. output current

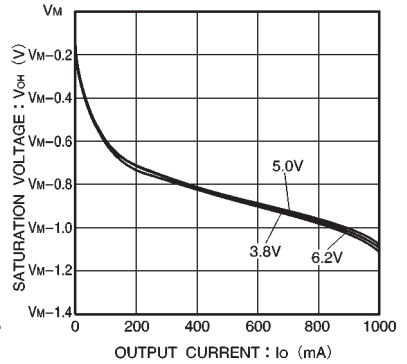
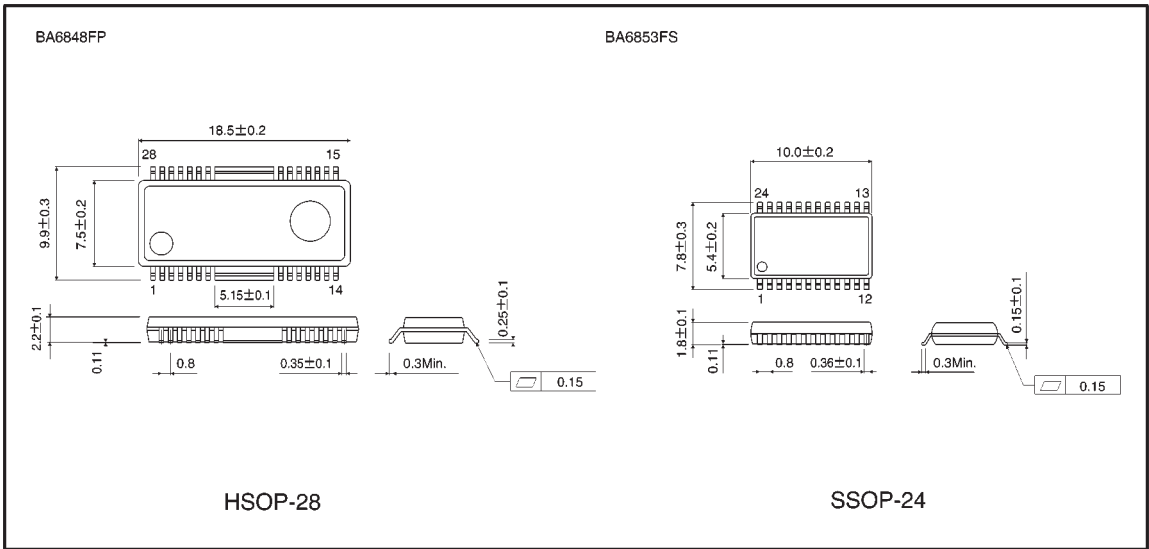

Fig.14 High level output saturation voltage vs. output current

●External dimensions (Units: mm)



This datasheet has been downloaded from:

www.DatasheetCatalog.com

Datasheets for electronic components.



LittleDiode supplies new, hard to find or obsolete electronic components and semiconductors all over the world.

With over two million different components listed you are sure to find the part you need.

Feel free to visit us today at our online store:

LittleDiode.com

Looking forward to providing you with the best possible service.