

# SYNC separator IC with AFC

## BA7046 / BA7046F

The BA7046 and BA7046F separate the synchronization signals from a video signal and output the horizontal and vertical synchronization signals ( $H_D$  and  $V_D$ ), and the composite synchronization signal (Sync-out). The  $H_D$  and  $V_D$  pulse phase difference is guaranteed.

### ●Applications

TVs and VCRs

### ●Features

- 1) Built-in AFC circuit.
- 2)  $H_D$  and  $V_D$  phase difference guaranteed.
- 3) Low power dissipation. (approx. 21mW)
- 4) Low external parts count.
- 5) 8-pin DIP / SOP package.
- 6) Horizontal free-run frequency does not require adjustment.

### ●Absolute maximum ratings ( $T_a = 25^\circ\text{C}$ )

#### BA7046 (DIP)

Parameter	Symbol	Limits	Unit
Power supply voltage	$V_{CC \text{ Max.}}$	8.0	V
Power dissipation	$P_d$	500*	mW
Operating temperature	$T_{opr}$	- 20 ~ + 75	$^\circ\text{C}$
Storage temperature	$T_{stg}$	- 55 ~ + 125	$^\circ\text{C}$

\* Reduced by 5mW for each increase in  $T_a$  of  $1^\circ\text{C}$  over  $25^\circ\text{C}$ .

#### BA7046F (SOP)

Parameter	Symbol	Limits	Unit
Power supply voltage	$V_{CC \text{ Max.}}$	8.0	V
Power dissipation	$P_d$	350*	mW
Operating temperature	$T_{opr}$	- 20 ~ + 75	$^\circ\text{C}$
Storage temperature	$T_{stg}$	- 55 ~ + 125	$^\circ\text{C}$

\* When mounted on a 50mm × 50mm PCB board, reduced by 3.5mW for each increase in  $T_a$  of  $1^\circ\text{C}$  over  $25^\circ\text{C}$ .

### ●Recommended operating conditions ( $T_a = 25^\circ\text{C}$ )

Parameter	Symbol	Min.	Typ.	Max.	Unit
Operating power supply voltage	$V_{CC}$	4.5	—	5.5	V

●Block diagrams

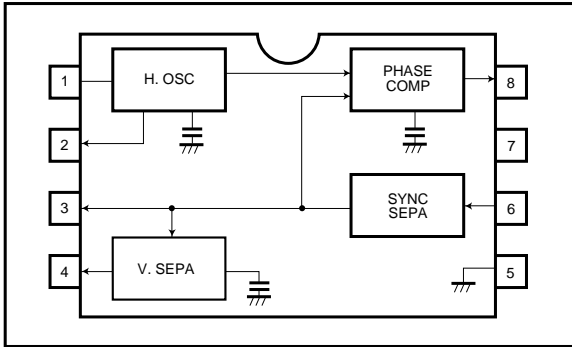

●Pin descriptions

Pin No.	Function
1	Horizontal oscillator resistor
2	H <sub>D</sub> output
3	SYNC output (open collector)
4	V <sub>D</sub> output
5	GND
6	Video input
7	Power supply
8	Phase comparator output

●Input / output circuits

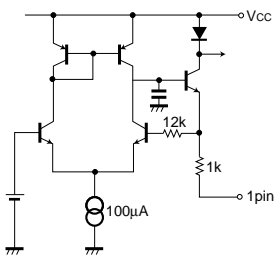

Fig. 1

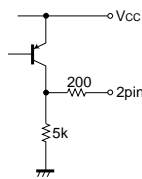

Fig. 2

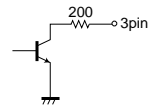

Fig. 3

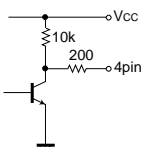

Fig. 4

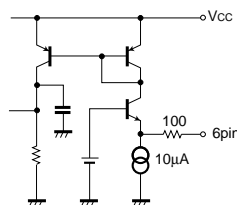

Fig. 5

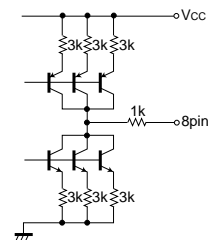

Fig. 6

●Electrical characteristics (unless otherwise noted Ta = 25°C and Vcc = 5.0V)

Parameter	Symbol	Min.	Typ.	Max.	Unit	Conditions
Quiescent current	I <sub>Q</sub>	2.0	4.1	6.2	mA	pin 3 open
Minimum synchronization separation level	V <sub>syn-Min.</sub>	—	0.08	0.15	V <sub>P-P</sub>	pin 6 terminated with 75Ω resistor
Pulse voltage, LOW	V <sub>P-L</sub>	—	0.1	0.3	V	pins 2, 4
Pulse voltage, HIGH	V <sub>P-H</sub>	4.7	4.9	—	V	pins 2, 4
(Horizontal) free-running frequency	f <sub>H-O</sub>	13.9	15.7	17.5	kHz	No input signal, I <sub>1</sub> = open
Capture range	Δf <sub>CAP</sub>	± 2.1	± 2.9	—	kHz	
Lock-in phase difference	T <sub>H<sub>PH</sub></sub>	- 1.0	0	+ 1.0	μs	pin2 ↘ pin- 6 ↘
H <sub>D</sub> , V <sub>D</sub> phase difference	T <sub>H<sub>VD</sub></sub>	17.0	23.5	30.0	μs	pin4 ↘ pin- 2 ↗
H <sub>D</sub> pulse width	T <sub>HD</sub>	4.6	5.1	5.6	μs	pin2 ↘ ↗
V <sub>D</sub> pulse width	T <sub>VD</sub>	190	230	270	μs	pin4 ↘ ↗

○ Not designed for radiation resistance.

●Measurement circuit

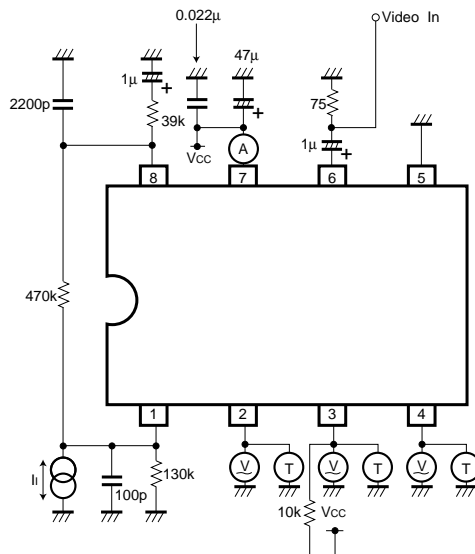

Fig. 7

●Circuit operation

(1) Synchronization separation circuit

Detects the charging current to an externally-connected capacitor, and performs synchronization separation.

(2) Horizontal oscillation circuit

When a video signal is input, it is synchronized with Hsync by the PLL. The horizontal free-running frequency

is determined by external resistor R1.

$$f_{H-O} = \frac{2.05E6}{R_1} \text{ [kHz]}$$

(3) Vertical synchronization separation circuit

When a video signal is input, synchronization signal separation is done over the vertical synchronization pulse interval.

●  $V_{IN}$ ,  $H_D$  and  $V_D$  timing charts

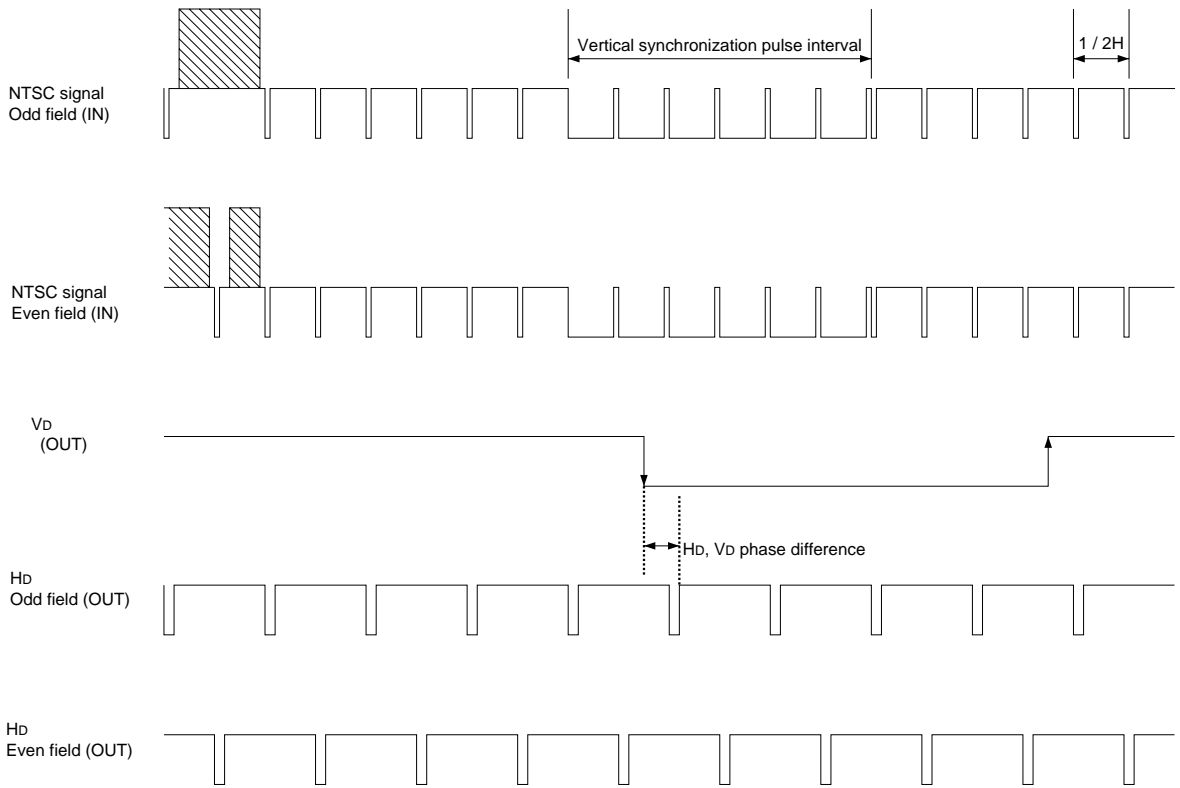
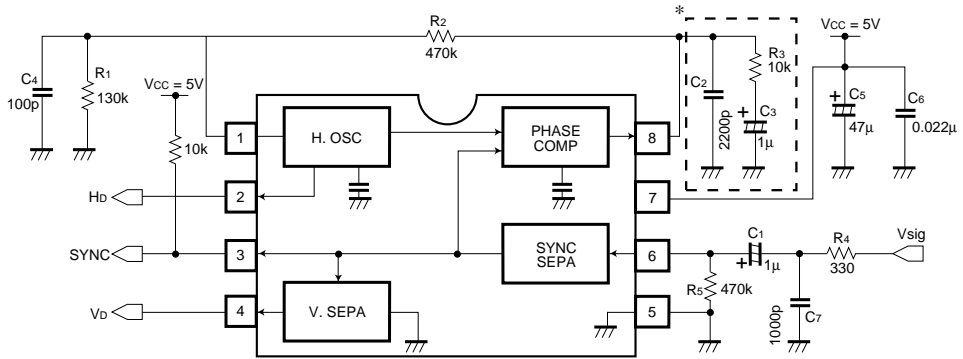

Fig. 8

- (1) The rise and fall positions for  $V_D$  are basically the same for both odd and even fields.
- (2)  $H_D$  shifts by  $1/2H$  during the odd and even field interval.
- (3) Only the odd field is given for the specification.

●Application example



\* By configuring the circuit enclosed in the dotted line to that in the diagram on the right, you can decrease the lock-in time and increase the capture range.

Fig.9

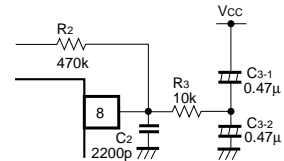

- When SYNC SEPA output only is used. Hb and Vb unused.

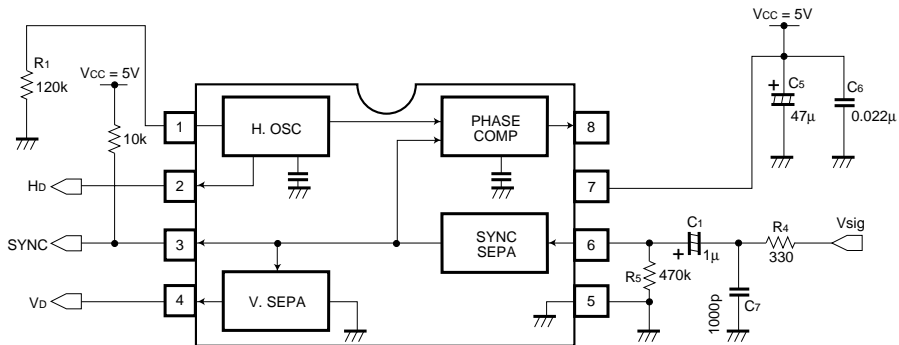

Fig. 10

- (1) Connect pin 1 to GND via a 120kΩ (approx.) resistor. Leave pins 2, 4 and 8 open.
- (2) SYNC output polarity (pin 3) is positive.
- (3) The delay time for rising edge of the SYNC output (pin 3) with respect to the falling edge of Sync for the Vsigt input signal (pin 6) is 850ns (reference value).
- (4) The delay time for falling edge of the SYNC output (pin 3) with respect to the rising edge of Sync for the Vsigt input signal (pin 6) is 450ns (reference value).

●Attached components

Resistor R1 should have a tolerance of ± 2%, and a temperature coefficient of 100ppm or lower.

●Electrical characteristic curves

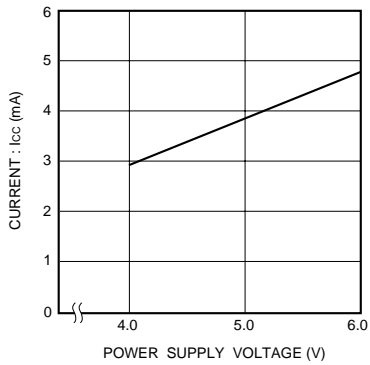

Fig. 11 Quiescent current vs. power supply voltage

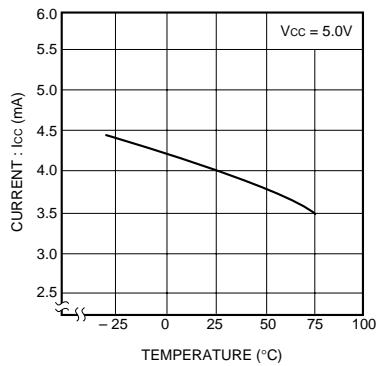

Fig. 12 Quiescent current vs. temperature

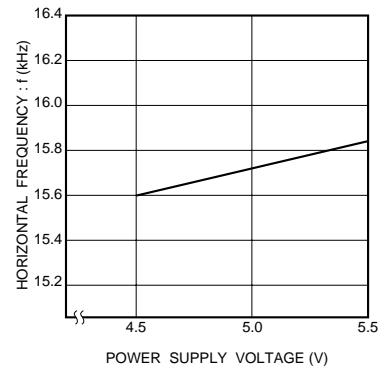

Fig. 13 Horizontal free-running frequency vs. power supply voltage

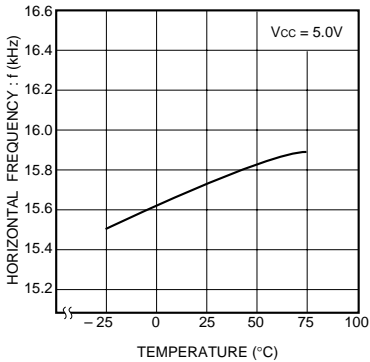

Fig. 14 Horizontal free-running frequency vs. temperature

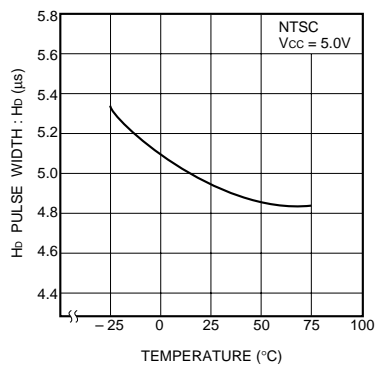

Fig. 15 Hd pulse width vs. temperature

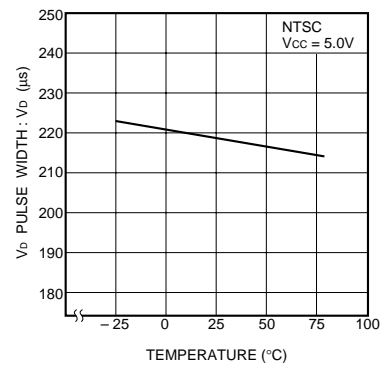

Fig. 16 Vd pulse width vs. temperature

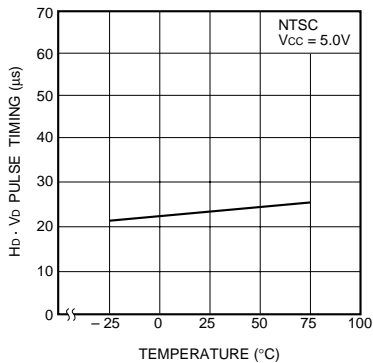

Fig. 17 Hd, Vd phase difference vs. temperature

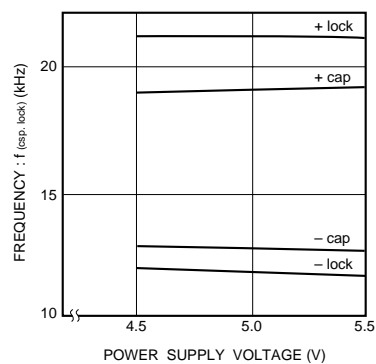

Fig. 18 Capture range / lock range vs. power supply voltage

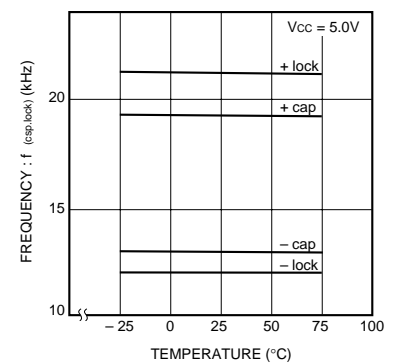

Fig. 19 Capture range charging / lock range vs. temperature

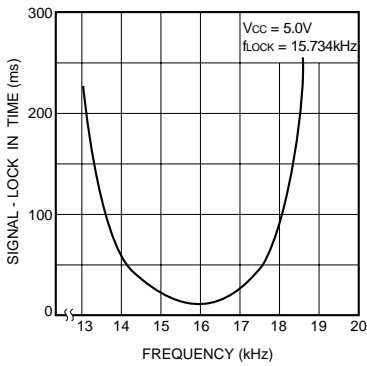

Fig. 20 Time from no signal to pull in

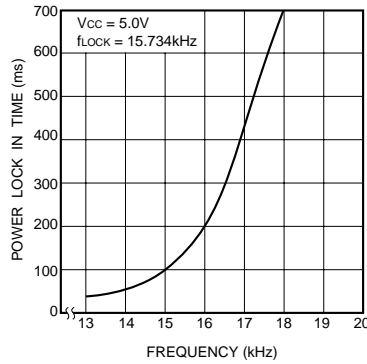
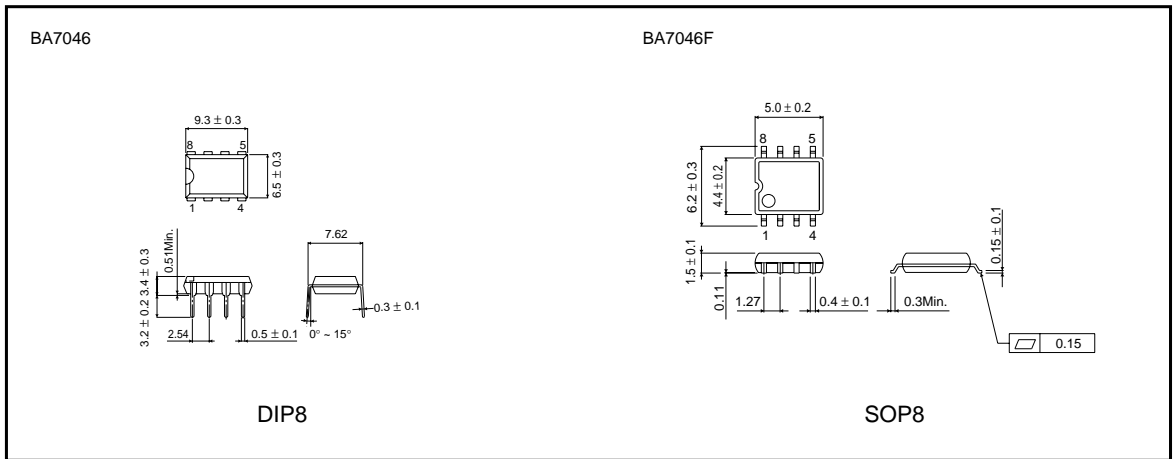

Fig. 21 Time from power on to pull in

● Operation notes

- Make the ground line as thick as possible.
- Keep power supply noise to a minimum.

● External dimensions (Units: mm)



This datasheet has been downloaded from:

[www.DatasheetCatalog.com](http://www.DatasheetCatalog.com)

Datasheets for electronic components.



LittleDiode supplies new, hard to find or obsolete electronic components and semiconductors all over the world.

With over two million different components listed you are sure to find the part you need.

Feel free to visit us today at our online store:

[LittleDiode.com](http://LittleDiode.com)

Looking forward to providing you with the best possible service.