

SYNC separator IC with AFC

BA7062F

The BA7062F separates the synchronization signals from a video signal and outputs the horizontal and vertical synchronization signals (H_D and V_D), and the composite synchronization signal (Sync-out).

The H_D and V_D pulse widths are different.

●Applications

TVs and VCRs

●Features

- 1) Built-in AFC circuit.
- 2) Low power dissipation (approx. 21mW).
- 3) Low external parts count.
- 4) SOP 8-pin package.
- 5) Horizontal free-run frequency does not require adjustment.

●Absolute maximum ratings ($T_a = 25^\circ\text{C}$)

Parameter	Symbol	Limits	Unit
Power supply voltage	$V_{CC \text{ Max.}}$	8.0	V
Power dissipation	P_d	350*	mW
Operating temperature	T_{opr}	- 20 ~ + 75	$^\circ\text{C}$
Storage temperature	T_{stg}	- 55 ~ + 125	$^\circ\text{C}$

* When mounted on a 50mm × 50mm PCB, reduced by 3.5mW for each increase in T_a of 1 $^\circ\text{C}$ over 25 $^\circ\text{C}$.

●Recommended operating conditions ($T_a = 25^\circ\text{C}$)

Parameter	Symbol	Min.	Typ.	Max.	Unit
Operating power supply voltage	V_{CC}	4.5	—	5.5	V

●Block diagram

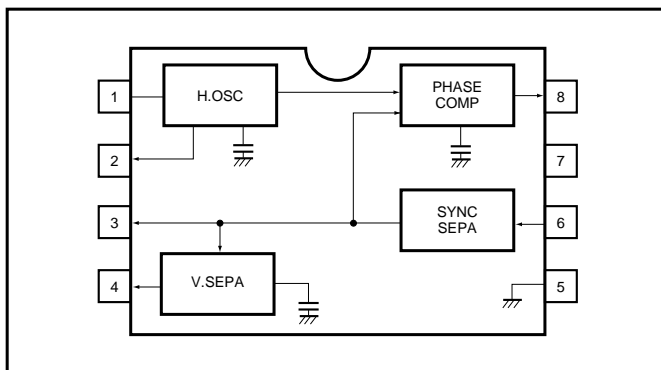

●Pin descriptions

Pin No.	Function
1	Horizontal oscillator resistor
2	Hb output
3	SYNC output (open collector)
4	Vb output
5	GND
6	Video input
7	Power supply
8	Phase comparator output

●Input / output circuits

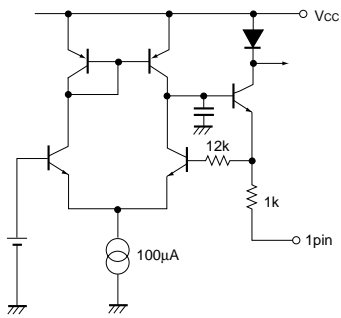

Fig. 1

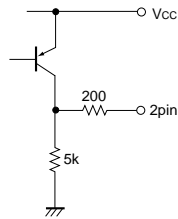

Fig. 2

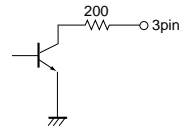

Fig. 3

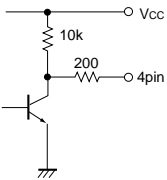

Fig. 4

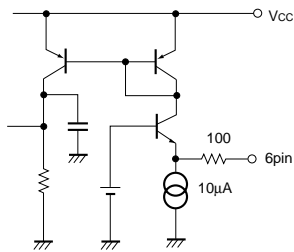

Fig. 5

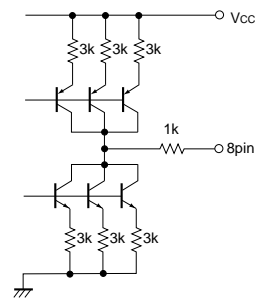

Fig. 6

● V_{IN} , H_D , and V_D timing charts

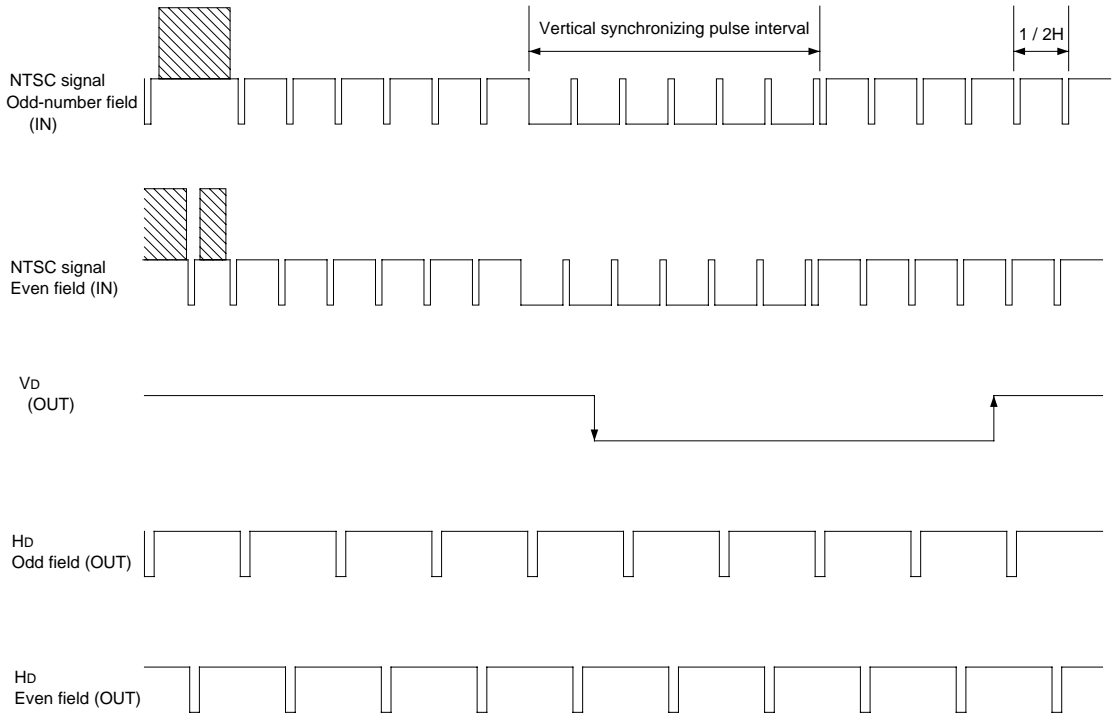
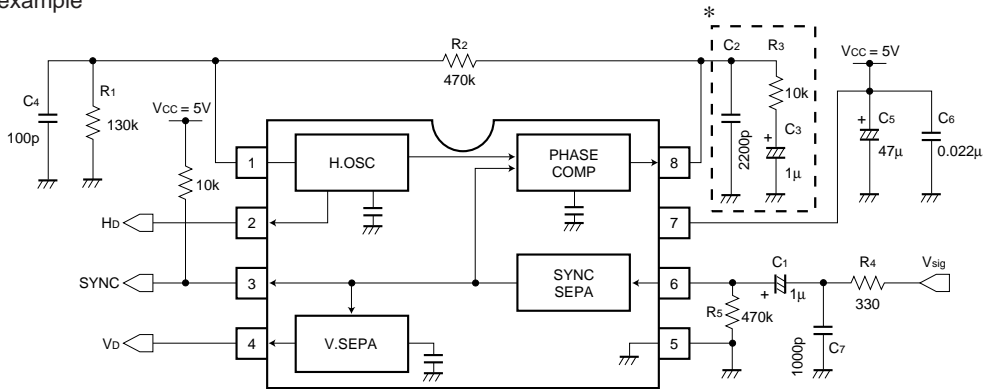

Fig. 8

- (1) The rise and fall positions for V_D are basically the same for both odd and even fields.
- (2) H_D shifts by $1/2H$ during the odd and even field interval.

●Application example



* By configuring the circuit enclosed in the dotted line to that in the diagram on the right, you can decrease the lock-in time and increase the capture range.

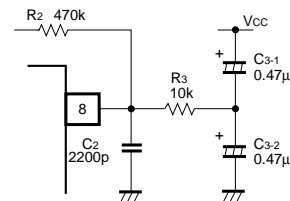

Fig. 9

• When SYNC SEPA output only is used. H_b and V_D unused.

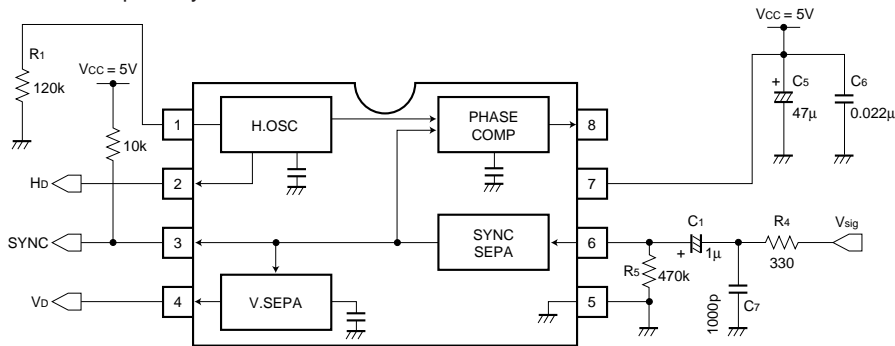

Fig. 10

- (1) Connect pin 1 to GND via a 120kΩ (approx.) resistor. Leave pins 2, 4 and 8 open.
- (2) SYNC output polarity (pin 3) is positive.
- (3) The delay time for rising edge of the SYNC output (pin 3) with respect to the falling edge of Sync for the V_{sig} input signal (pin 6) is 850ns (reference value).
- (4) The delay time for falling edge of the SYNC output (pin 3) with respect to the rising edge of Sync for the V_{sig} input signal (pin 6) is 450ns (reference value).

●Attached components

Resistor R₁ should have a tolerance of ± 2%, and a temperature coefficient of 100ppm or lower.

● Electrical characteristic curves

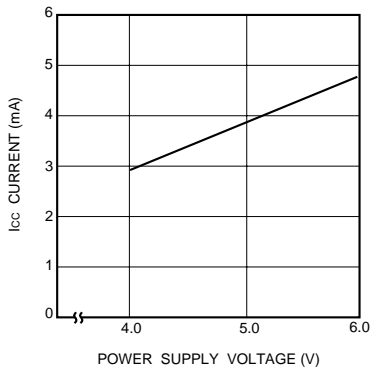

Fig. 11 Quiescent current vs. power supply voltage

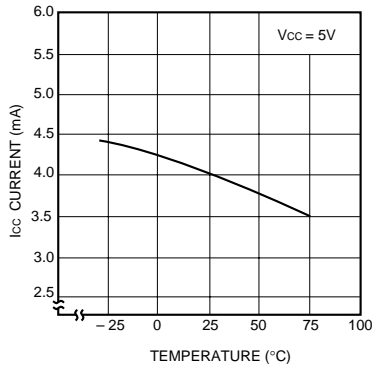

Fig. 12 Quiescent current vs. temperature

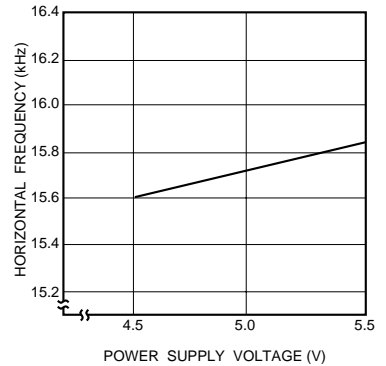

Fig. 13 Horizontal free-running frequency vs. power supply voltage

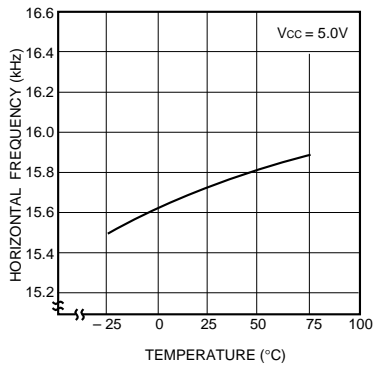

Fig. 14 Horizontal free-running frequency vs. temperature

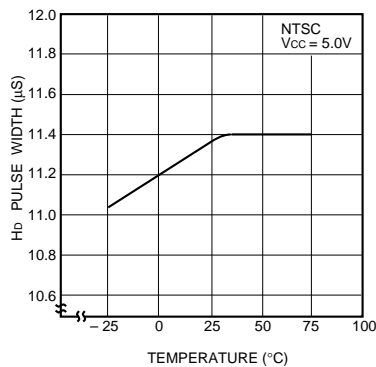

Fig. 15 H_b pulse width vs. temperature

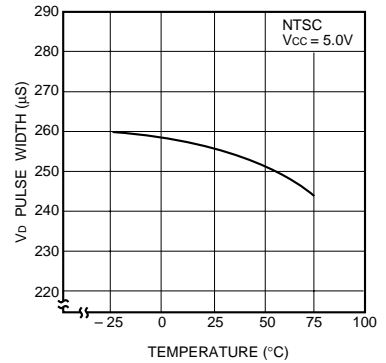

Fig. 16 V_d pulse width vs. temperature

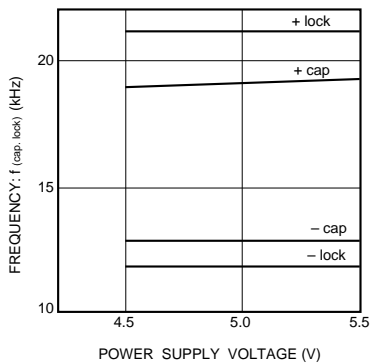

Fig. 17 Capture range / lock range vs. power supply voltage

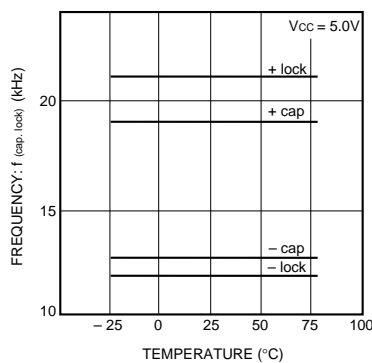

Fig. 18 Capture range / lock range vs. temperature

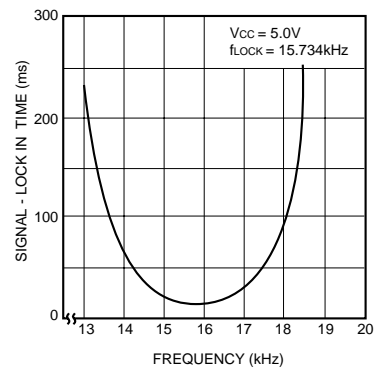

Fig. 19 Time from no signal to pull in

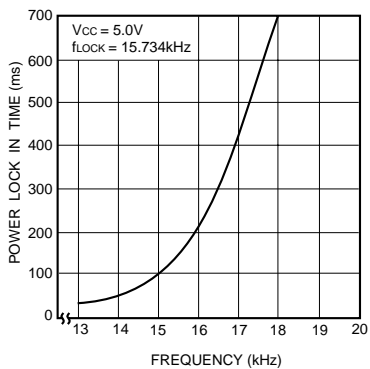
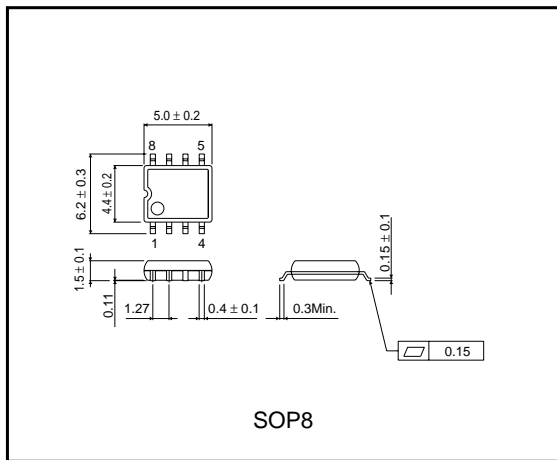

Fig. 20 Time from power on to pull in

● Operation notes

- Make the ground line as thick as possible.
- Keep power supply noise to a minimum.

● External dimensions (Units: mm)





LittleDiode supplies new, hard to find or obsolete electronic components and semiconductors all over the world.

With over two million different components listed you are sure to find the part you need.

Feel free to visit us today at our online store:

LittleDiode.com

Looking forward to providing you with the best possible service.