

Synchronization signal processor for high definition displays

BA7078AF/AS

The BA7078AF is a synchronization signal processing LSI chip designed for multiscan high-definition displays. It generates a synchronization signal and clamp pulse for three types of input signals: separate synchronization, composite synchronization, and synchronization on video.

●Application

CRT displays

●Features

- 1) Operates on a single 5V power supply, with low power consumption.
- 2) Synchronization signal existence and polarity detection output.
- 3) Adjustable clamp pulse width, allowing for the selection of front or back editing.
- 4) Vertical synchronization separation is based on horizontal frequency tracking, for separation starting at 1H.
- 5) Minimal attached components.

●Absolute maximum ratings (Ta = 25°C)

Parameter	Symbol	Limits	Unit
Power supply voltage	V _{cc}	7.0	V
Power dissipation	Pd	*1 450(BA7078AF)	mW
		*2 600(BA7078AS)	
Operating temperature	T _{opr}	-25 to +75	°C
Storage temperature	T _{stg}	-55 to +125	°C

*1 Reduced by 4.5mW for each increase in Ta of 1°C over 25°C.

*2 Reduced by 6.0mW for each increase in Ta of 1°C over 25°C.

●Recommended operating conditions (Ta = 25°C)

Parameter	Symbol	Min.	Typ.	Max.	Unit
Power supply voltage	V _{cc}	4.5	5.0	5.5	V

Multimedia ICs

●Block diagram

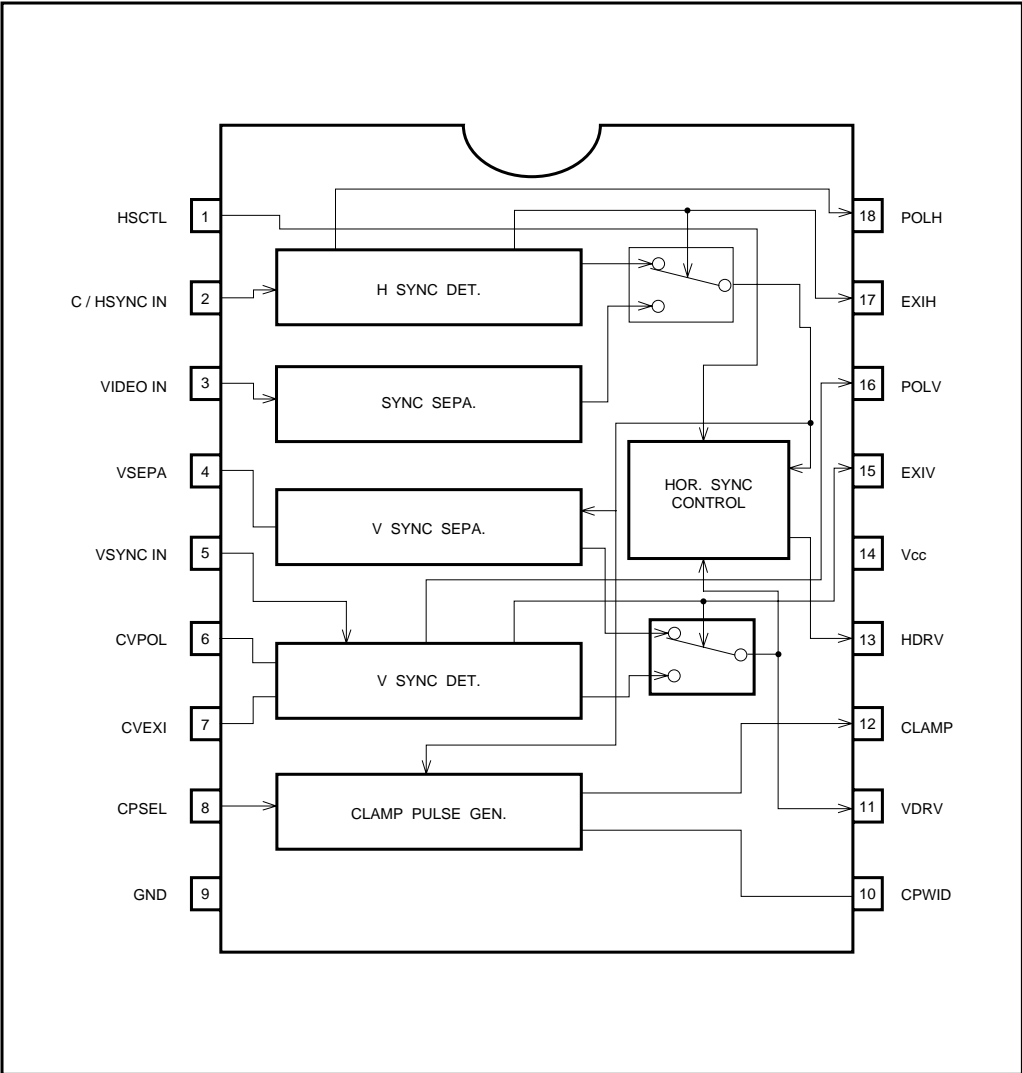

Multimedia ICs

●Pin descriptions

Pin No.	Pin name	Functions	
1	HSCTL	HDRV output	Used to select whether to output the VDRV section of the HDRV output signal. High : VDRV section of HDRV is output Low : VDRV section of HDRV is not output
2	C / HSYNC IN	Composite sync / H SYNC input	Input either the composite synchronization signal or the horizontal synchronization signal. Input is clamped, and is initiated by capacitor coupling.
3	VIDEO IN	SYNC ON VIDEO input	Inputs the SYNC ON VIDEO signal(green). Input is sink chip clamped. Input is initiated by capacitor coupling.
4	VSEPA	f-V conversion	Converts the horizontal synchronization signal frequency into a voltage. The voltage generated is proportional to the frequency of the horizontal synchronization signal. Attach a 0.56 μ F capacitor between the ground pins.
5	VSIN	V SYNC input	Inputs the vertical synchronization signal.
6	CVPOL	Vertical polarity integration	Integrates the vertical synchronization signal polarity detection circuit. Attach a 1.5 μ F capacitor between this pin and the ground.
7	CVEXI	Vertical existence integration	Integrates the vertical synchronization signal existence detection circuit. Attach a 1 μ F capacitor between this pin and the ground.
8	CPSEL	Setting the clamp position	Used to set the clamp pulse generation position to either the front or back edge of HSYNC High : The front edge is the generation position Open : Composite / H SYNC IN : The front edge is the generation position VIDEO IN : The back edge is the generation position Low : The back edge is the generation position
9	GND	Ground	–
10	CPWID	Setting the clamp pulse width	Sets the clamp pulse width according to the attached time constant. Attach a resistor between this pin and V _{cc} and, a capacitor between this pin and GND. When R = 3.9k Ω and C = 100pF, pulse width is approximately 400 ns. Set the resistor to register an abnormality at 1k Ω .
11	VDRV	VDRV output	Outputs the vertical synchronization signal. The output signal has positive polarity.
12	CLAMP	Clamp output	Outputs the clamp pulse generated from the vertical synchronization signal. The output signal has a positive polarity.
13	HDRV	HDRV output	Outputs the clamp pulse generated from the horizontal synchronization signal. The output signal has positive polarity.
14	V _{cc}	Power supply	–
15	EXIV	Vertical existence output	Indicates whether the vertical synchronization signal exists. For the output logic, refer to the separate table.
16	POLV	Vertical polarity output	Indicates the polarity of the vertical synchronization signal. For the output logic, refer to the separate table.
17	EXIH	Horizontal existence output	Indicates whether the horizontal synchronization signal exists. For the output logic, refer to the separate table.
18	POLH	Horizontal polarity output	Indicates the polarity of the horizontal synchronization signal. For the output logic, refer to the separate table.

Multimedia ICs

●Input / output circuits

HSTL

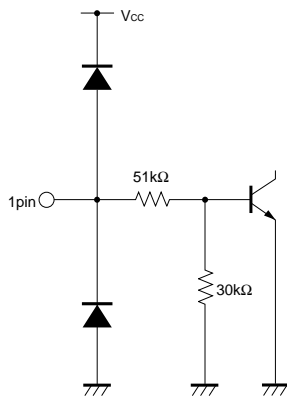

VSEPA

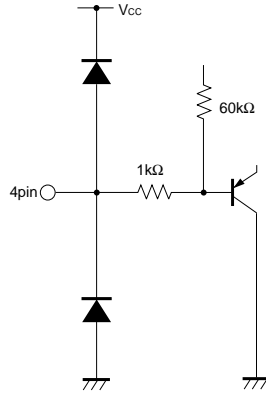

C / HSYNC IN

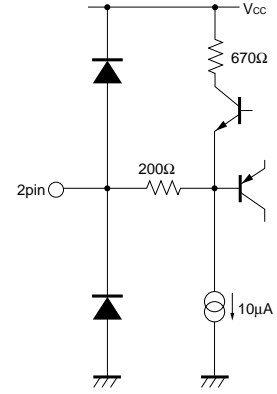

VSYNC IN

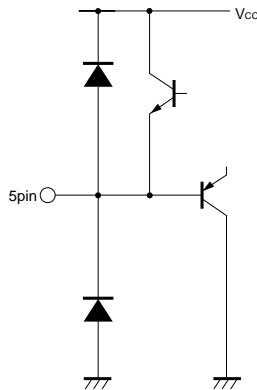

VIDEO IN

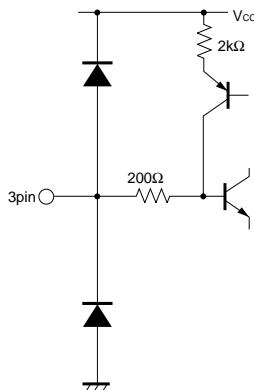

CVPOL

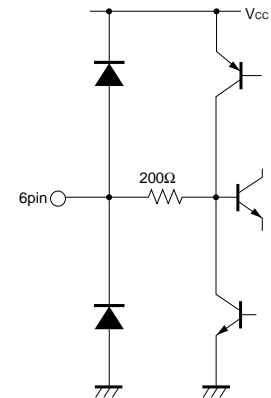

CVEXI

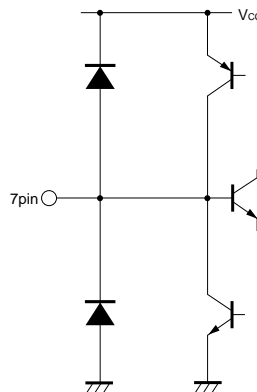

CPWID

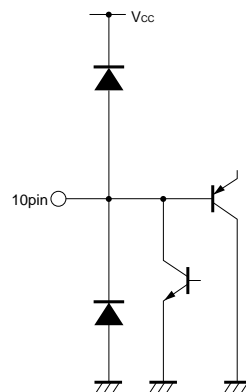

CPSEL

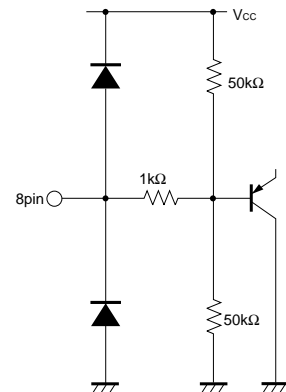

Multimedia ICs

VDRV

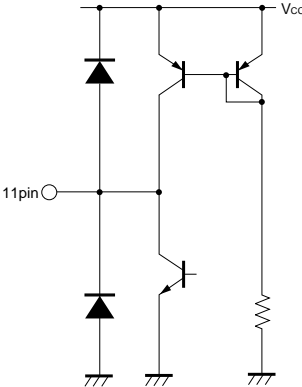

GND

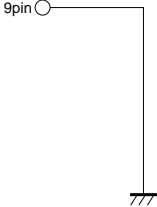

CLAMP

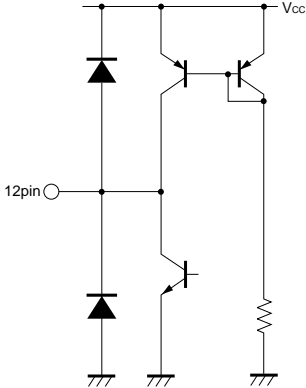

HDRV

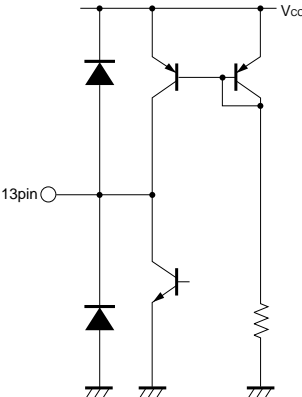

POLV

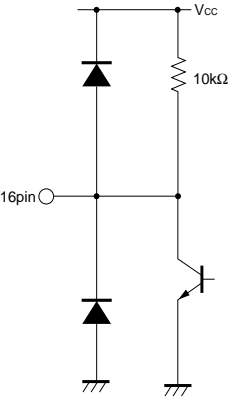

Vcc

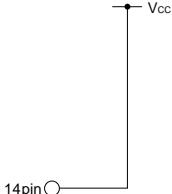

EXIH

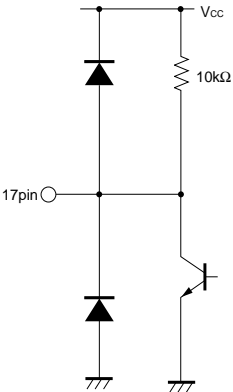

EXIV

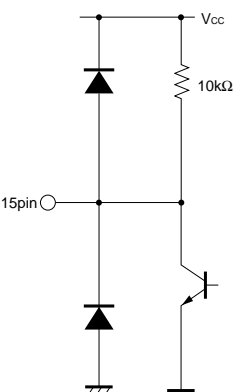

POLH

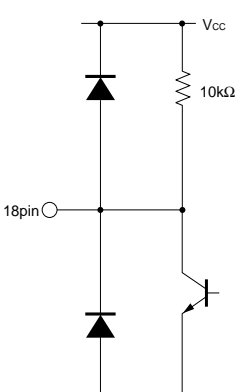

Multimedia ICs

●Electrical characteristics (unless otherwise noted, $V_{CC} = 5V$, $T_a = 25^{\circ}C$)

Parameter	Symbol	Min.	Typ.	Max.	Unit	Conditions
Power supply voltage	V_{CC}	4.5	5.0	5.5	V	
Quiescent current	I_{CC}	21	30	39	mA	
VDRV output voltage "H"	V_{VDH}	4.5	5.0	–	V	
VDRV output voltage "L"	V_{VDL}	–	0.2	0.5	V	
VDRV output current "L"	I_{VDL}	8	–	–	mA	
VDRV rising delay time	trd_{VD}	–	280	450	ns	VSYNC IN
HDRV output voltage "H"	V_{HDH}	4.5	5.0	–	V	
HDRV output voltage "L"	V_{HDL}	–	0.2	0.5	V	
HDRV output current "L"	I_{HDL}	8	–	–	mA	
HDRV rising delay time (1)	trd_{HD1}	–	65	115	ns	C / HSYNC IN
HDRV rising delay time (2)	trd_{HD2}	–	95	145	ns	VIDEO IN
CLAMP output voltage "H"	V_{CPH}	4.5	5.0	–	V	
CLAMP output voltage "L"	V_{CPL}	–	0.2	0.5	V	
CLAMP output current "L"	I_{CPL}	8	–	–	mA	
CLAMP rising delay time (1)	trd_{CP1}	–	75	125	ns	front edge
CLAMP rising delay time (2)	trd_{CP2}	–	95	145	ns	back edge
Synchronization detection output voltage "H"	V_{DH}	4.5	5.0	–	V	
Synchronization detection output voltage "L"	V_{DL}	–	0.2	0.5	V	
Synchronization detection output current "L"	I_{DL}	3	–	–	mA	
Synchronization detection output impedance	Z_{oD}	7	10	13	$k\Omega$	
Minimum synchronization separation level	$V_{SMin.}$	–	–	0.2	V_{P-P}	
HSCCTL "H" level threshold voltage	V_{tHSH}	2.5	–	–	V	
HSCCTL "L" level threshold voltage	V_{tHSL}	–	–	1.5	V	
CPSEL "H" level threshold voltage	V_{tCPH}	3.8	–	–	V	
CPSEL "L" level threshold voltage	V_{tCPL}	–	–	1.2	V	

●Synchronization signal detection chart

INPUT		OUTPUT			
Composite / HSYNC	VSYNC	EXIH	EXIV	POLH	POLV
H. COMP (Positive)	No signal	H	L	L	L
	Positive	H	H	L	L
	Negative	H	H	L	H
H. COMP (Negative)	No signal	H	L	H	L
	Positive	H	H	H	L
	Negative	H	H	H	H
No signal	No signal	L	L	L	L
	Positive	L	H	L	L
	Negative	L	H	L	H

Multimedia ICs

●Relationship between INPUT to OUTPUT

INPUT			OUTPUT		
Composite / HSYNC	VSYNC	VIDEO	HDRV	VDRV	CLAMP
-	-	○	VIDEO	VIDEO	VIDEO
○	-	○	CS	CS	CS
-	○	○	VIDEO	VS	VIDEO
○	○	○	CS	VS	CS
-	-	-	-	-	-
○	-	-	CS	CS	CS
-	○	-	-	VS	-
○	○	-	CS	VS	CS

Explanation of symbol ○ : Signal Input - : No Signal

●Input signal range

Parameter	Vert. separate sync	Hor. separate sync	Composite sync	Sync on Video
Polarity	Posi. / Neg.	Posi. / Neg.	Posi. / Neg.	Neg.
Amplitude (Sync) : Vs (Video) : Vv	1.0 to 5.0V _{P-P}	1.0 to 5.0V _{P-P}	1.0 to 5.0V _{P-P}	0.2 to 0.6V _{P-P} 0 to 2.1V _{P-P}
Vert. sync frequency range : fV	40 to 200Hz	-	40 to 200Hz	40 to 200Hz
Vert. sync pulse width range : pwV	8.0μs to Duty35%	-	* 1HMin. to 400μs	* 1HMin.
Hor. sync frequency range : fH	-	15k to 200kHz	15k to 200kHz	15k to 200kHz
Hor. sync pulse width range : pwH	-	94ns to Duty35%	94ns to Duty30%	Duty30% Max.

* 1H = 1 / fH

●Input signal waveform

Vert. / Hor. separate sync

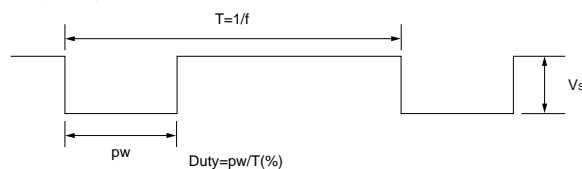

Composite sync

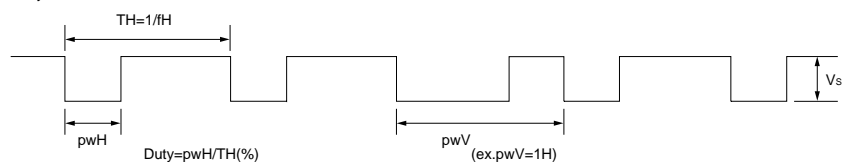

Sync on Video

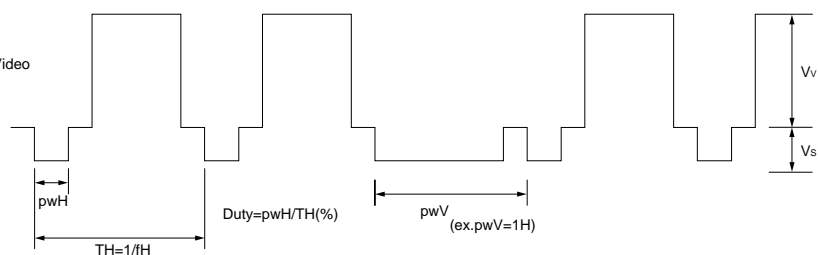

Multimedia ICs

●Measurement circuit

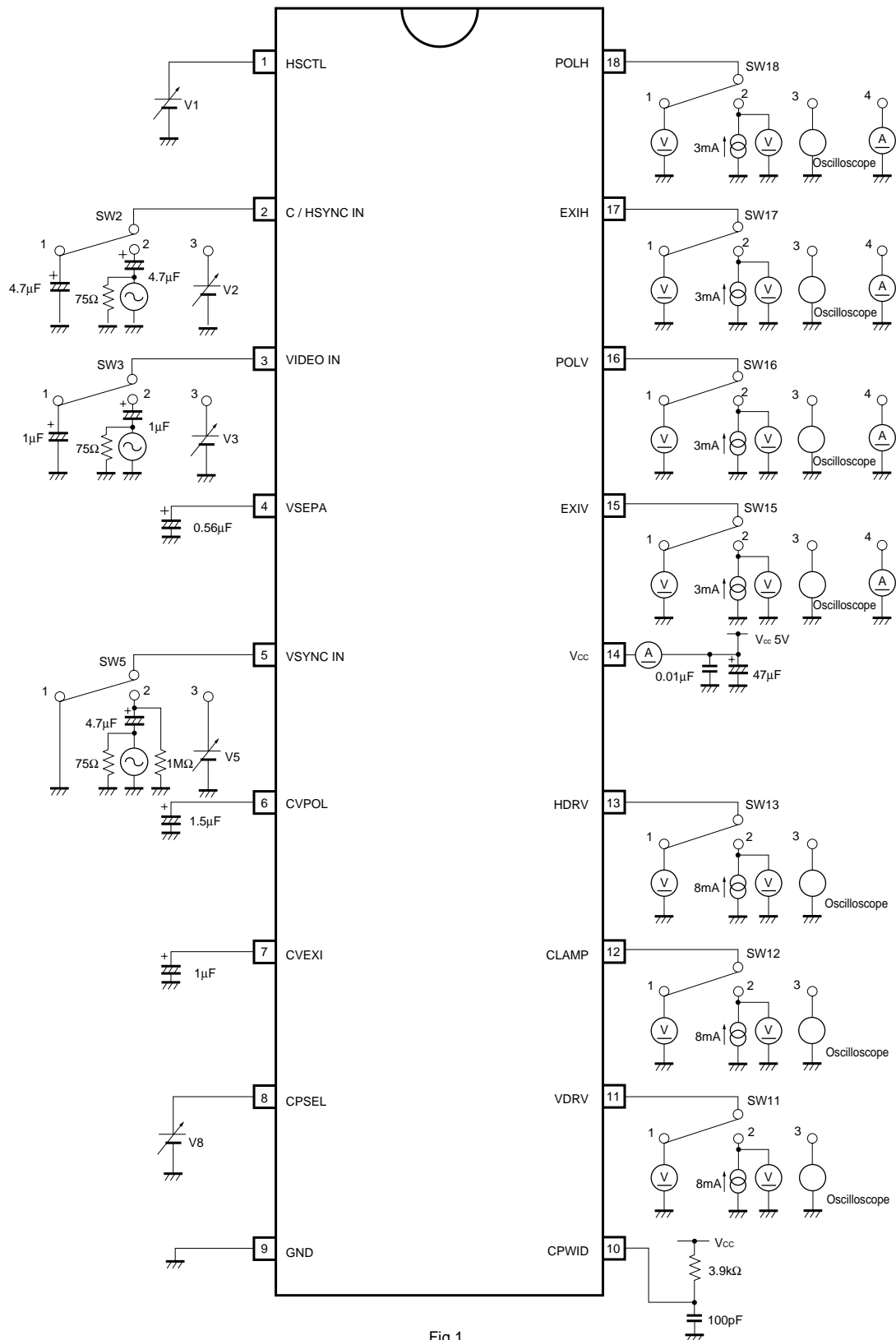

Fig.1

Multimedia ICs

●Conditions for measurement of electrical characteristics

Parameter	Switch condition									
	2	3	5	11	12	13	15	16	17	18
Quiescent current	1	1	1	1	1	1	1	1	1	1
VDRV output voltage "H"	1	1	3	1	1	1	1	1	1	1
VDRV output voltage "L"	1	1	3	1	1	1	1	1	1	1
VDRV output current "L"	1	1	3	2	1	1	1	1	1	1
VDRV rising delay time	1	1	2	3	1	1	1	1	1	1
HDRV output voltage "H"	3	1	1	1	1	1	1	1	1	1
HDRV output voltage "L"	3	1	1	1	1	1	1	1	1	1
HDRV output current "L"	3	1	1	1	1	2	1	1	1	1
HDRV rising delay time (1)	2	1	1	1	1	3	1	1	1	1
HDRV rising delay time (2)	1	2	1	1	1	3	1	1	1	1
CLAMP output voltage "H"	2	1	1	1	3	1	1	1	1	1
CLAMP output voltage "L"	2	1	1	1	3	1	1	1	1	1
CLAMP output current "L"	3	1	1	1	2	1	1	1	1	1
CLAMP rising delay time (1)	2	1	1	1	3	1	1	1	1	1
CLAMP rising delay time (2)	1	2	1	1	3	1	1	1	1	1
POLH output voltage "H"	2	1	1	1	1	1	1	1	1	1
POLH output voltage "L"	2	1	1	1	1	1	1	1	1	1
POLH output current "L"	3	1	1	1	1	1	1	1	1	2
POLH output impedance	3	1	1	1	1	1	1	1	1	4
EXIH output voltage "H"	2	1	1	1	1	1	1	1	1	1
EXIH output voltage "L"	1	1	1	1	1	1	1	1	1	1
EXIH output current "L"	3	1	1	1	1	1	1	1	2	1
EXIH output impedance	3	1	1	1	1	1	1	1	4	1
POLV output voltage "H"	1	1	2	1	1	1	1	1	1	1
POLV output voltage "L"	1	1	2	1	1	1	1	1	1	1
POLV output current "L"	1	1	3	1	1	1	1	2	1	1
POLV output impedance	1	1	3	1	1	1	1	4	1	1
EXIV output voltage "H"	1	1	2	1	1	1	1	1	1	1
EXIV output voltage "L"	1	1	1	1	1	1	1	1	1	1
EXIV output current "L"	1	1	3	1	1	1	2	1	1	1
EXIV output impedance	1	1	3	1	1	1	4	1	1	1
Minimum synchronization separation level	1	2	1	1	1	3	1	1	1	1
HSCTL "H" level threshold voltage	2	1	2	1	1	3	1	1	1	1
HSCTL "L" level threshold voltage	2	1	2	1	1	3	1	1	1	1
CPSEL "H" level threshold voltage	1	2	1	1	3	3	1	1	1	1
CPSEL "L" level threshold voltage	2	1	1	1	3	3	1	1	1	1

●Application example

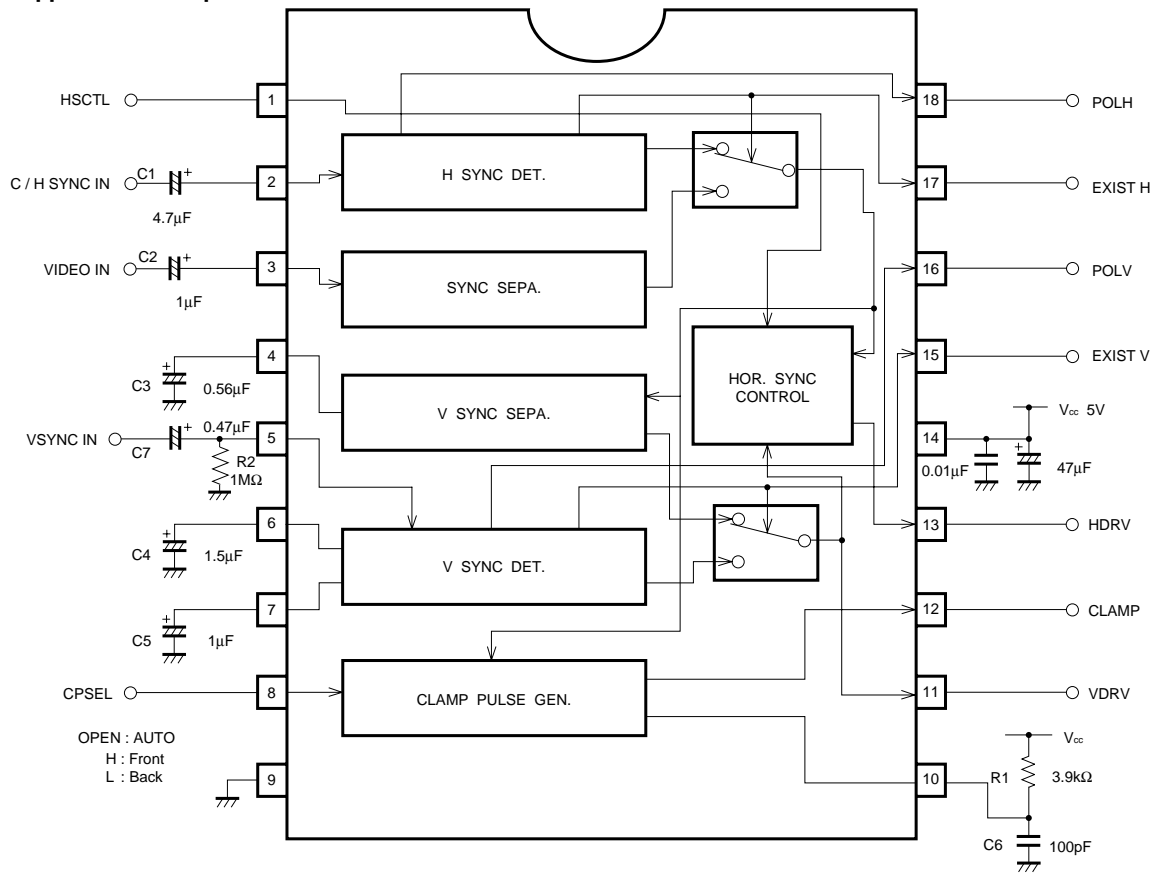
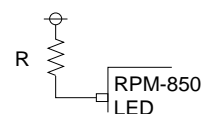

Fig.2

Multimedia ICs

●Attached components

- R : The resistor for limiting the LED current.
Use the resistor of not less than 1W.
- C1 : 47 μ F Coupling capacitor for C / H SYNC IN
A low capacitance increases the size of the input pin waveform's sag.
- C2 : 1 μ F Coupling capacitor for VIDEO IN
A low capacitance increase the size of the input pin waveform's sag.
- C3 : 0.56 μ F Conversion capacitor for f-V
A low capacitance increase the size of the ripple of the f-V conversion voltage. A large capacitance is not a problem, but will delay the reaction speed.
- C4 : 1.5 μ F Capacitor for POLH (detection of the vertical synchronization signal's polarity)
The minimum capacitance is determined as follows:
The internal hysteresis comparator does not react when the duty of minimum frequency synchronization (fV = 40Hz, T = 25ms) is 50%.
 $C_{Min.} = 16\mu \times T [F]$
A large capacitance is not a problem, built will deray the reaction speed.
- C5 : 1 μ F Capacitor for EXIH (detection of the vertical synchronization signal's existance)
The minimum capacitance is determined as follows:
The internal hysteresis comparator does not react at the minimum frequency synchronization (fV = 40Hz, T = 25ms)
 $C_{Min.} = 16\mu \times T [F]$
A large capacitance is not a problem, but will deray the reaction speed.
- C6 : 100pF Constant for setting the clamp pulse width
- C7 : 0.47 μ F Coupling capacitor for VSYNC IN
A low capacitance increases the size of the input pin waveform's sag.
- R1 : 3.9k Ω A low resistance results in a narrow clamp pulse width. Set no lower than 1k Ω .
- R2 : 1M Ω Discharge current setting resistor for CLAMP IN



Multimedia ICs

●Electrical characteristic curves

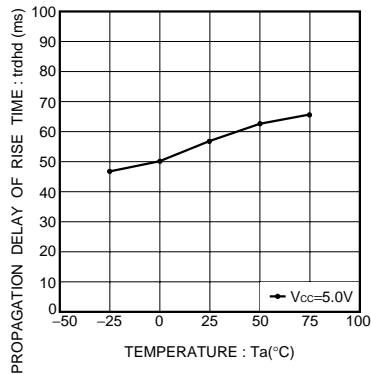

Fig.3 C / HSYNC IN-HDRV
Rising delay time vs. temperature

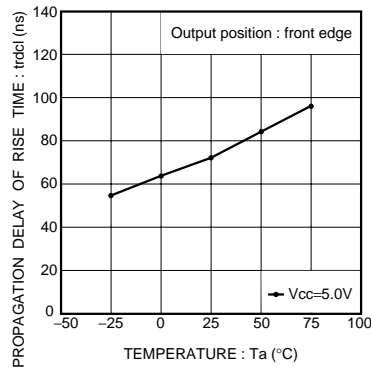

Fig.4 C / HSYNC IN-CLAMP
Rising delay time vs. temperature

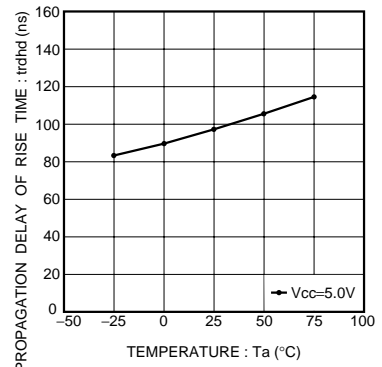

Fig.5 VIDEO IN-HDRV
Rising delay time vs. temperature

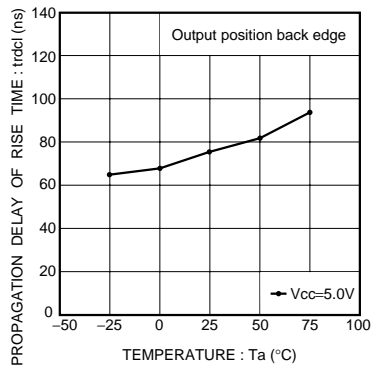

Fig.6 VIDEO IN-CLAMP
Rising delay time vs. temperature

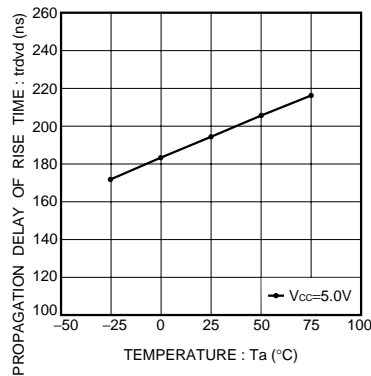

Fig.7 VSYNC IN-VDRV
Rising delay time vs. temperature

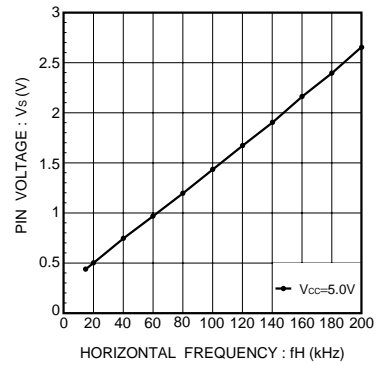
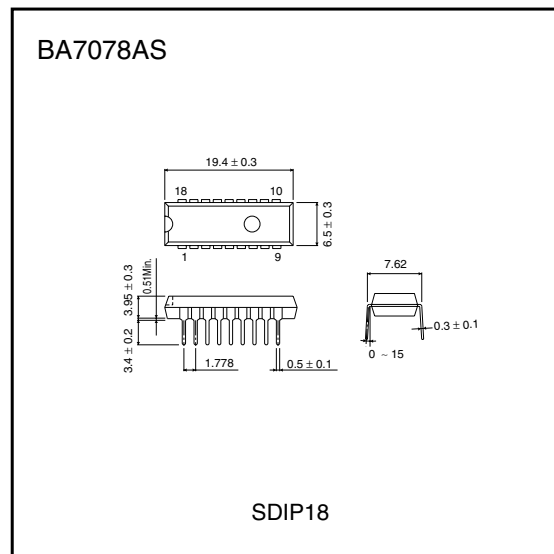
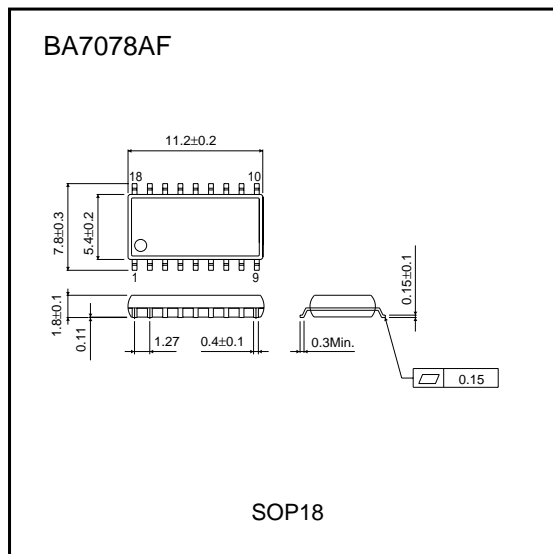

Fig.8 VSEPA horizontal frequency vs. pin voltage

●External dimensions (Unit : mm)



Notes

- No technical content pages of this document may be reproduced in any form or transmitted by any means without prior permission of ROHM CO.,LTD.
- The contents described herein are subject to change without notice. The specifications for the product described in this document are for reference only. Upon actual use, therefore, please request that specifications to be separately delivered.
- Application circuit diagrams and circuit constants contained herein are shown as examples of standard use and operation. Please pay careful attention to the peripheral conditions when designing circuits and deciding upon circuit constants in the set.
- Any data, including, but not limited to application circuit diagrams information, described herein are intended only as illustrations of such devices and not as the specifications for such devices. ROHM CO.,LTD. disclaims any warranty that any use of such devices shall be free from infringement of any third party's intellectual property rights or other proprietary rights, and further, assumes no liability of whatsoever nature in the event of any such infringement, or arising from or connected with or related to the use of such devices.
- Upon the sale of any such devices, other than for buyer's right to use such devices itself, resell or otherwise dispose of the same, no express or implied right or license to practice or commercially exploit any intellectual property rights or other proprietary rights owned or controlled by
- ROHM CO., LTD. is granted to any such buyer.
- Products listed in this document use silicon as a basic material.
Products listed in this document are no antiradiation design.

The products listed in this document are designed to be used with ordinary electronic equipment or devices (such as audio visual equipment, office-automation equipment, communications devices, electrical appliances and electronic toys).

Should you intend to use these products with equipment or devices which require an extremely high level of reliability and the malfunction of which would directly endanger human life (such as medical instruments, transportation equipment, aerospace machinery, nuclear-reactor controllers, fuel controllers and other safety devices), please be sure to consult with our sales representative in advance.

About Export Control Order in Japan

Products described herein are the objects of controlled goods in Annex 1 (Item 16) of Export Trade Control Order in Japan.

In case of export from Japan, please confirm if it applies to "objective" criteria or an "informed" (by MITI clause) on the basis of "catch all controls for Non-Proliferation of Weapons of Mass Destruction.

This datasheet has been downloaded from:

www.DatasheetCatalog.com

Datasheets for electronic components.



LittleDiode supplies new, hard to find or obsolete electronic components and semiconductors all over the world.

With over two million different components listed you are sure to find the part you need.

Feel free to visit us today at our online store:

LittleDiode.com

Looking forward to providing you with the best possible service.