

4-channel PRE / REC amplifier with auto-tracking interface

BA7184S

The BA7184S is a PRE / REC amplifier developed for use in video cassette recorders. It is compatible with four-head decks and features built-in FB damping, four preamplifiers, a chroma output amplifier, an FM output amplifier (with AGC), an envelope detector and envelope comparator, a constant-current BTL-drive REC amplifier (with AGC) and channel switching, EP / SP switching, and mode switching integrated onto a single monolithic IC.

●Applications

VCRs

●Features

- 1) The playback amplifier has a total gain of 56dB (Typ.), and has a low-noise preamplifier. Designed for VHS band operation with low external parts count. The IC has 4 circuits for 4-head VCR applications.
- 2) Two playback output systems (through output and AGC output). The AGC output level is 315mV_{P-P} (Typ.); suitable for FM brightness signal output.
- 3) Auto-tracking interface for automated tracking adjustment. Linear detector characteristic with sensitivity that can be set using external components.
- 4) The recording amplifier uses constant-current BLT drive that handles load variations (i.e. headimpedance) well, and gives stable recording characteristics. 2 circuits are provided for 4-head VCR use.
- 5) Built-in recording level AGC means adjustment of FM recording current is not necessary.
- 6) Head switches for 4-channel PRE / REC system provided.
- 7) Operates off a single 5V power supply, with low power dissipation.

●Absolute maximum ratings (Ta = 25°C)

Parameter	Symbol	Limits	Unit
Applied voltage	V _{cc}	7.0	V
Power dissipation	P _d	1050*1	mW
Operating temperature	T _{opr}	- 20 ~ + 65	°C
Storage temperature	T _{stg}	- 55 ~ + 125	°C

*1 Reduced by 10.5mW for each increase in Ta of 1°C over 25°C (free air).

●Recommended operating conditions (Ta = 25°C)

Parameter	Symbol	Min.	Typ.	Max.	Unit	Conditions
Playback / recording	V _{cc}	4.5	5.0	5.5	V	13pin

○ Not designed for radiation resistance.

●Block diagram

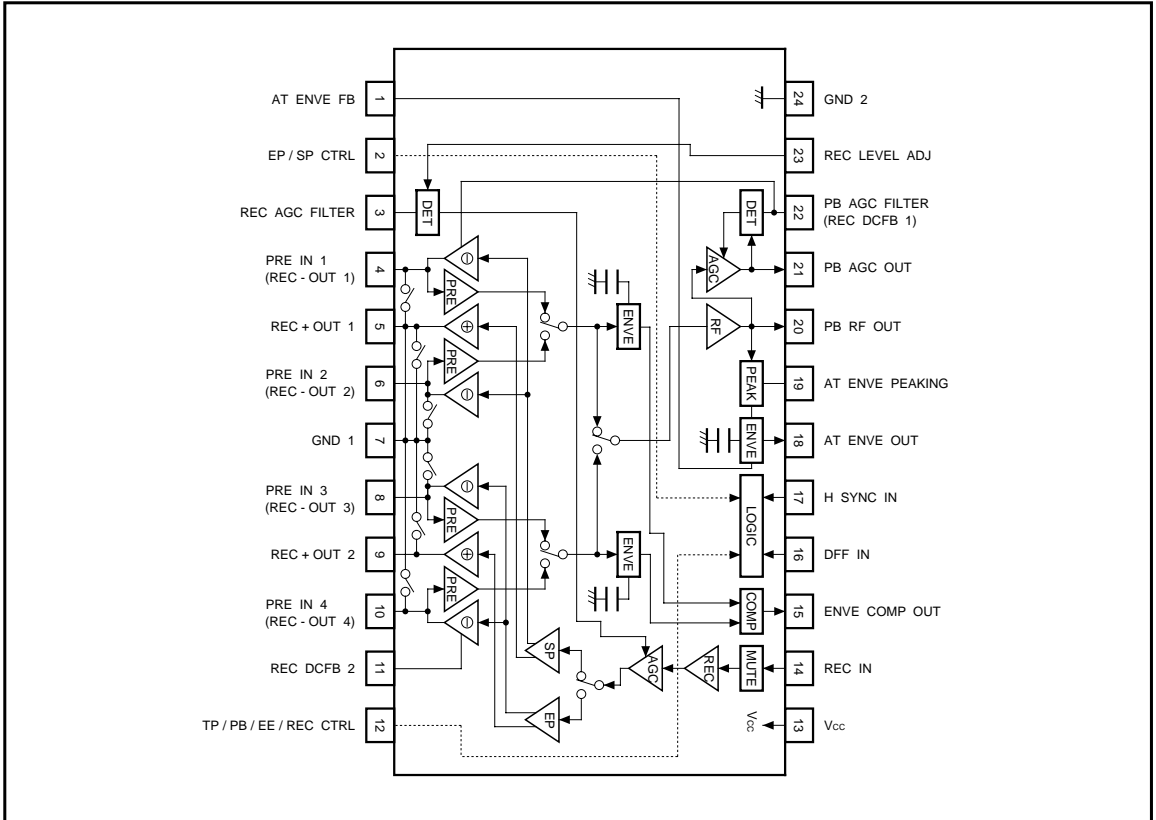

●Electrical characteristics (unless otherwise noted, Ta = 25°C, Vcc = 5.0V and f = 4.0MHz)

Parameter	Symbol	Min.	Typ.	Max.	Unit	Conditions	Measurement circuit
(Playback system) (Pin 12: H)							
Supply current	Iq (P)	—	27	45	mA	No signal	Fig. 1
Voltage gain ch-1	G _{VP1}	52	56	60	dB	Pin 4 input = 0.3mV _{P-P} , pin 2: L, pin 16: L, pin 20 output measurement	Fig. 1
Voltage gain ch-2	G _{VP2}	52	56	60	dB	Pin 6 input = 0.3mV _{P-P} , pin 2: L, pin 16: H, pin 20 output measurement	Fig. 1
Voltage gain ch-3	G _{VP3}	52	56	60	dB	Pin 8 input = 0.3mV _{P-P} , pin 2: H, pin 16: L, pin 20 output measurement	Fig. 1
Voltage gain ch-4	G _{VP4}	52	56	60	dB	Pin 10 input = 0.3mV _{P-P} , pin 2: H, pin 16: H, pin 20 output measurement	Fig. 1
Voltage gain differential	ΔG _{VP}	-1.5	—	+1.5	dB	ΔG _{VP} = G _{VP1} - G _{VP2} , G _{VP3} - G _{VP4}	Fig. 1
Frequency characteristic	ΔG _{VI}	-8	-1.7	—	dB	Pin 20 output level difference for f = 8.0 / 1.0MHz, V _{IN} = 0.3mV _{P-P} .	Fig. 1
2nd harmonic distortion	2HDP	—	-42	-35	dBc	V _{IN} = 0.3mV _{P-P} , 8.0MHz spurious	Fig. 1
3rd harmonic distortion	3HDP	—	-50	-35	dBc	V _{IN} = 0.3mV _{P-P} , 12.0MHz spurious*2	Fig. 1
Maximum output level	V _{OMP}	0.8	1.2	—	V _{P-P}	When pin 20 output 2nd harmonic distortion is -30dBc	Fig. 1
Crosstalk	CT _P	—	-45	-30	dBc	Pin 20 output level difference for pin 2: H / L, pin 16: H / L.	Fig. 1
Output DC offset	ΔV _{ODC}	—	—	200	mV _{P-P}	Pin 20 output DC offset for pin 2: H / L, pin 16: H / L.	Fig. 1
Input conversion noise	V _{NIN}	—	0.25	1.0	μVrms	Rg = 10Ω, input conversion of pin 20 output noise*2	Fig. 1
AGC output level	V _{AGC}	265	315	365	mV _{P-P}	V _{IN} = 0.3mV _{P-P} , pin 21 output measurement	Fig. 1
AGC control sensitivity	ΔV _{AGC}	—	0.3	2.0	dB	Pin 21 output level differential for V _{IN} = 0.15 to 0.6mV _{P-P} .	Fig. 1
AGC frequency characteristic	ΔG _{VAF}	-8	-3	—	dB	f = 8.0 / 1.0MHz, V _{IN} = 0.3mV _{P-P} *2	Fig. 1
PB switch ON resistance	R _{ON5,9}	—	5	10	Ω	Pin 5 and pin 9 impedance*2	Fig. 1
ENVE residual voltage	V _{ENV1}	—	0.7	1.0	V	Pin 18 output measurement when no signal	Fig. 1
ENVE output level	V _{ENV2}	2.4	2.9	3.4	V	Pin 18 output measurement when pin 20 output = 400mV _{P-P}	Fig. 1
ENVE saturation voltage	V _{ENV3}	4.0	4.5	—	V	Pin 18 output measurement for large signal	Fig. 1
PRE ch 2 and 4 holding voltage	V _{TH16H}	3.5	—	V _{CC}	V	Pin 16 DC voltage for ch 2 and 4 operation	Fig. 1
PRE ch 1 and 3 holding voltage	V _{TH16L}	0	—	1.2	V	Pin 16 DC voltage for ch 1 and 3 operation	Fig. 1
EP mode holding voltage	V _{TH2H}	3.5	—	V _{CC}	V	Pin 2 DC voltage for EP mode	Fig. 1
SP mode holding voltage	V _{TH2L}	0	—	1.2	V	Pin 2 DC voltage for SP mode	Fig. 1
TP mode holding voltage	V _{TH12T}	4.1	—	V _{CC}	V	Pin 12 DC voltage for TRICK PLAY mode	Fig. 1
PB mode holding voltage	V _{TH12H}	3.0	—	3.7	V	Pin 12 DC voltage for PB mode	Fig. 1
EE mode holding voltage	V _{TH12M}	1.1	—	2.6	V	Pin 12 DC voltage for REC MUTE mode	Fig. 1
REC mode holding voltage	V _{TH12L}	0	—	0.7	V	Pin 12 DC voltage for REC mode	Fig. 1

*2 Guaranteed design values.

Note: dBc: dB below carrier (used to express relative level from carrier reference for convenience sake)

Parameter	Symbol	Min.	Typ.	Max.	Unit	Conditions	Measurement circuit
(Recording system) (Pin 12: L)							
Quiescent current	$I_{q(R)}$	—	67	100	mA	No signal	Fig. 2
Recording AGC level 1	I_{OAR1}	27	30	33	mA _{P-P}	Pin 14 input = 125mV _{P-P} , pin 2: L, pin 5 output measurement	Fig. 2
Recording AGC level 2	I_{OAR2}	24	27	30	mA _{P-P}	Pin 14 input = 125mV _{P-P} , pin 2: H, pin 9 output measurement	Fig. 2
AGC control sensitivity	ΔI_{OAR}	—	0.3	2.0	dB	Pin 14 input = 62.5mV _{P-P} , to 250mV _{P-P} , pin 5 output level differential	Fig. 2
AGC frequency characteristic	ΔI_{OAF}	-8	-3	—	dB	f = 8.0 / 1.0MHz, pin 14 input = 125mV _{P-P} ,*2	Fig. 2
2nd harmonic distortion	2H _{DR}	—	-45	-35	dBc	Pin 14 input = 125mV _{P-P} , 8MHz spurious	Fig. 2
3rd harmonic distortion	3H _{DR}	—	-50	-35	dBc	Pin 14 input = 125mV _{P-P} , 12.0MHz spurious*2	Fig. 2
Cross modulation distortion	CMD _R	—	-50	-35	dBc	4.0MHz ± 630kHz spurious*2	Fig. 2
Maximum output level	I_{OMR}	40	50	—	mA _{P-P}	When pin 5 output 2nd harmonic distortion is -30dB	Fig. 2
Recording current load characteristic	ΔI_{ORL}	-2.0	-0.3	—	dB	Pin 5 output level difference when load L: 8.2 and 12μH*2	Fig. 2
Mute attenuation ratio	MU _R	—	-45	-35	dBc	Pin 5 output level difference for pin 12: M / L	Fig. 2
AGC mode holding voltage	V_{TH17H}	2.8	—	V_{CC}	V	Pin 17 DC voltage to maintain recording AGC operation.	Fig. 2
AGC mode holding voltage	V_{TH17L}	0	—	1.2	V	Pin 17 DC voltage to maintain recording AGC stopped.	Fig. 2

*2 Guaranteed design values.

Note: dBc: dB below carrier (used to express relative level from carrier reference for convenience sake)

● Measurement circuits
(Playback system)

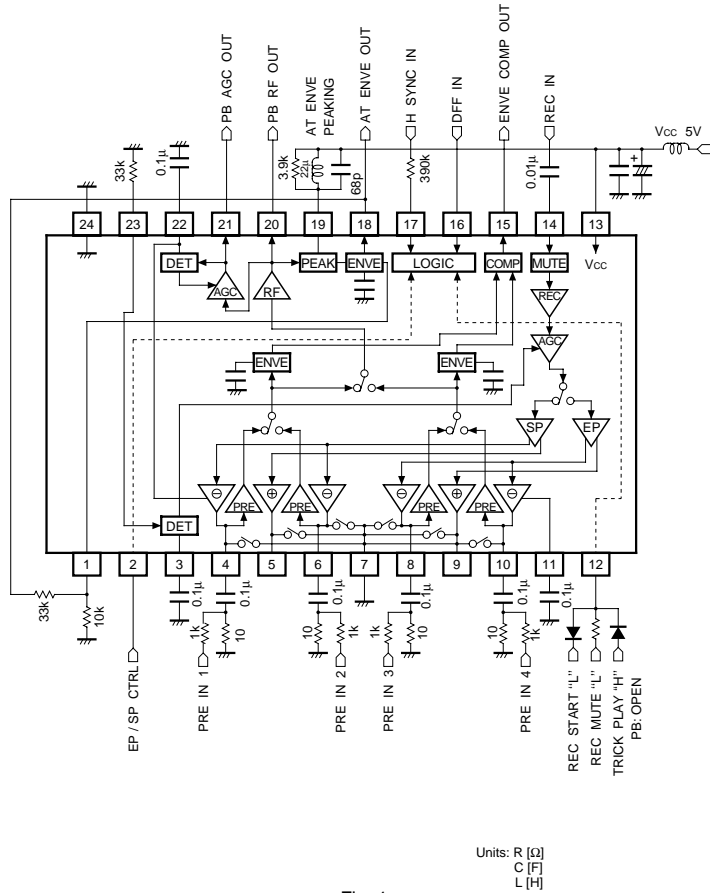
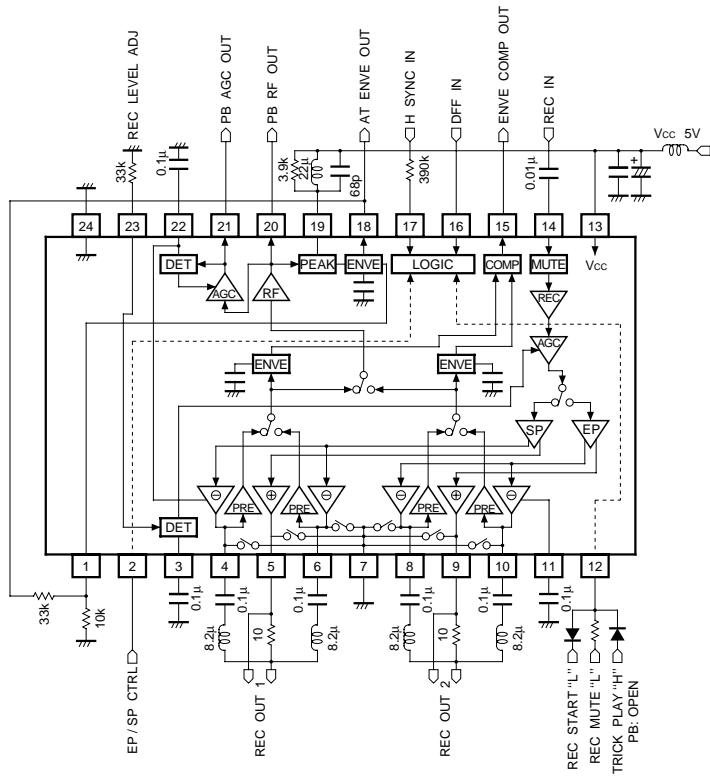

Fig. 1

(Recording system)



Units: R [Ω]
C [F]
L [H]

Fig. 2

●Control system logic table

(1) DFF IN (pin 16)

- Playback input selection (head switching)

Control pin		Function	Control voltage V_{CTRL16} [V]
DFF IN	EP / SP	Selected playback input	
L	H	Ch3 (PRE IN3 8pin)	3.5 ~ V_{CC}
H		Ch4 (PRE IN4 10pin)	0.0 ~ 1.2
L	L	Ch1 (PRE IN1 4pin)	—
H		Ch2 (PRE IN2 6pin)	—

(2) EP / SP control (pin 2)

- Recording output selection
- Playback input selection (see (1))

Control pin		Function	Control voltage V_{CTRL2} [V]
EP / SP		Selected recording output	
H		EP (REC OUT 8, 9, 10pin)	3.5 ~ V_{CC}
L		SP (REC OUT 4, 5, 6pin)	0.0 ~ 1.2

(3) TP / PB / EE / REC CTRL (pin 12)

- Special playback / playback / recording mute / recording mode switching

Control pin	Mode	Function					Control voltage V_{CTRL12} [V]
		PRE AMP	AT ENVE	ENV COMP	REC MUTE	REC AMP	
OT	TRICK PLAY	ON	ON	ON	OFF	OFF	4.1 ~ V_{CC}
H	PB	ON	ON	OFF	OFF	OFF	3.0 ~ 3.7
M	REC MUTE	OFF	OFF	OFF	ON	ON	1.1 ~ 2.6
L	REC	OFF	OFF	OFF	OFF	ON	0.0 ~ 0.7

- Pin 12 is biased internally in the IC. When open, PB mode is selected.

(4) H SYNC IN (pin 17)

- Special playback envelope comparator (ENVE COMP) output latch control.
- AGC operation control for recording.

Control pin		Function		Control voltage V_{CTRL17} [V]
H SYNC		ENVE COMP	AGC detector	
H		Set at falling edge	ON	2.8 ~ V_{CC}
L		—	OFF	0.0 ~ 1.2

(5) ENVE COMP OUT (pin 15)

- Outputs playback envelope comparator data for special playback.

Control pin	Function
ENVE COMP	Playback input level
H	Ch1 or Ch2 > Ch3 or Ch4
L	Ch1 or Ch2 < Ch3 or Ch4

●Application example

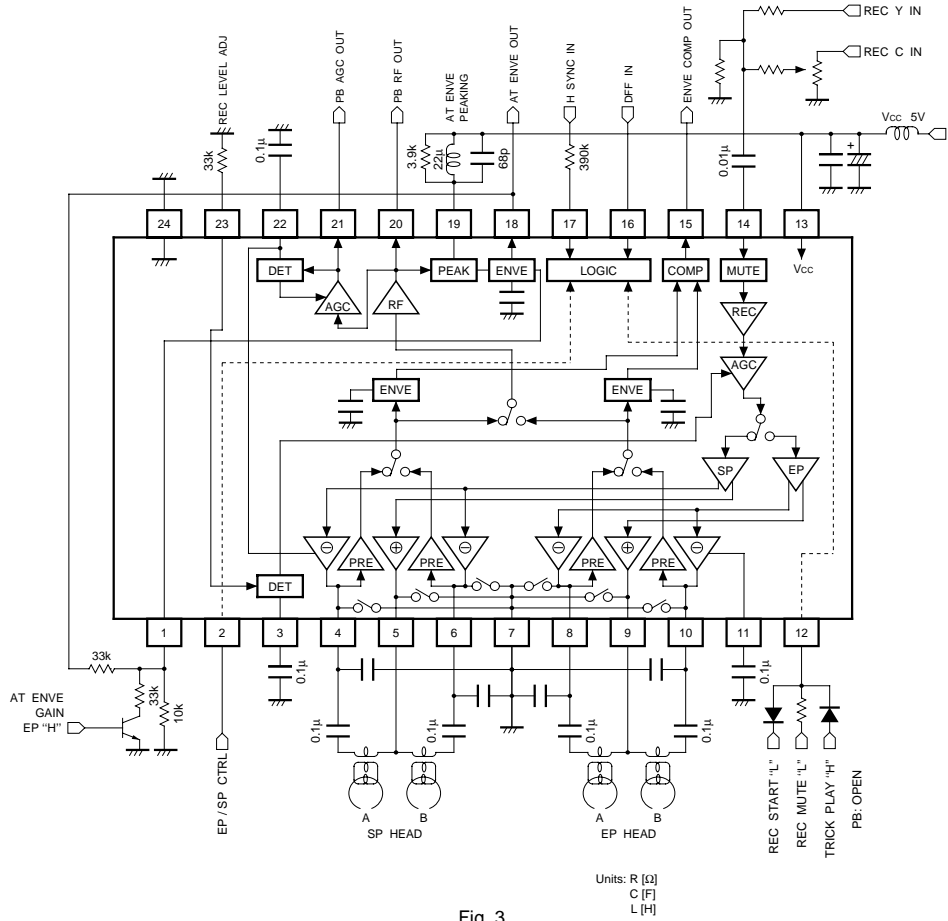
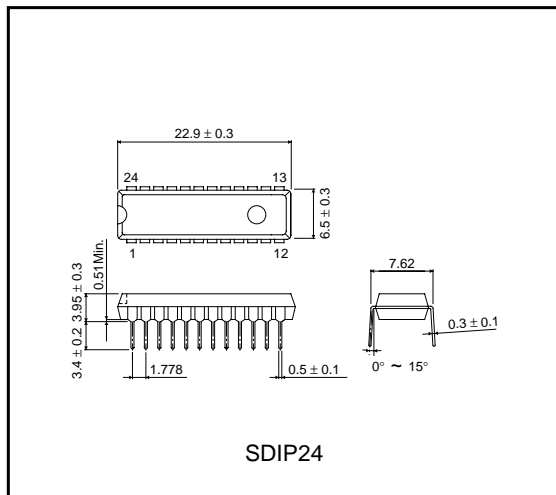

Fig. 3

●External dimensions (Units: mm)





LittleDiode supplies new, hard to find or obsolete electronic components and semiconductors all over the world.

With over two million different components listed you are sure to find the part you need.

Feel free to visit us today at our online store:

LittleDiode.com

Looking forward to providing you with the best possible service.