

Video signal switcher

BA7612N / BA7612F

The BA7612N and BA7613F are three-channel analog multiplexers with built-in mute, 6dB amplifier and 75Ω driver. The ICs designed for use in video cassette recorders, and feature a large dynamic range and wide operating frequency range. All inputs are terminated with 20kΩ (Typ.) input impedance.

●Applications

Video cassette recorders and televisions

●Features

- 1) 3-input / 1-output switches.
- 2) Built-in 6dB amplifier and 75Ω driver.
- 3) Built-in mute.
- 4) Large input impedance (20kΩ Typ.).
- 5) Wide operating supply voltage range (4.5V ~ 13.0V BA7612N) (4.5V ~ 9.5V BA7613F).
- 6) Low power dissipation (103mW Typ.).
- 7) Excellent frequency characteristics (10MHz, 0dB Typ.).
- 8) Wide dynamic range (3.5V_{P-P} Typ.).
- 9) Low interchannel crosstalk (– 65dB Typ., f = 4.43MHz).

●Block diagram

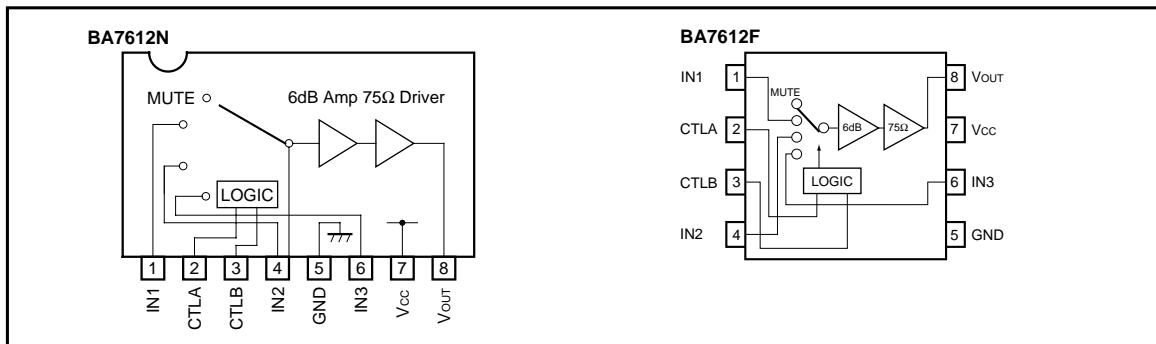

●Truth table

CTL A	CTL B	OUT
L (OPEN)	L (OPEN)	IN1
L (OPEN)	H	IN2
H	L (OPEN)	IN3
H	H	MUTE

● Absolute maximum ratings (Ta = 25°C)

Parameter	Symbol	Limits	Unit
Power supply voltage	V _{CC}	*113.5 / *210.0	V
Power dissipation	P _d	*1900*3 / *2550*4	mW
Operating temperature	T _{opr}	- 25 ~ + 75	°C
Storage temperature	T _{stg}	- 55 ~ + 125	°C

*1 BA7612N

*2 BA7612F

*3 Reduced by 9mW for each increase in Ta of 1°C over 25°C.

*4 Reduced by 5.5mW for each increase in Ta of 1°C over 25°C.

● Electrical characteristics (unless otherwise noted, Ta = 25°C and V_{CC} = 5V)

Parameter	Symbol	Min.	Typ.	Max.	Unit	Conditions
Operating voltage range	V _{CC}	4.5	—	13.0	V	BA7612F is Max.9.5V
Supply current	I _{CC}	—	20.5	29.0	mA	
Maximum output level	V _{om}	3.0	3.5	—	V _{P-P}	f = 1kHz, THD = 0.5%
Voltage gain	G _v	5.5	6.0	6.5	dB	f = 1MHz, V _{IN} = 1.0V _{P-P}
Interchannel crosstalk	C _T	—	- 65	—	dB	f = 4.43MHz, V _{IN} = 1.0V _{P-P}
Frequency characteristic	C _f	- 3.0	0	1.0	dB	f = 10MHz / 1MHz, V _{IN} = 1.0V _{P-P}
Input impedance	Z _{IN}	14	20	26	kΩ	
CTL pin switching level A	V _{TH-A}	1.0	2.0	3.0	V	
CTL pin switching level B	V _{TH-B}	1.0	2.0	3.0	V	

○ Not designed for radiation resistance.

● Measurement circuit

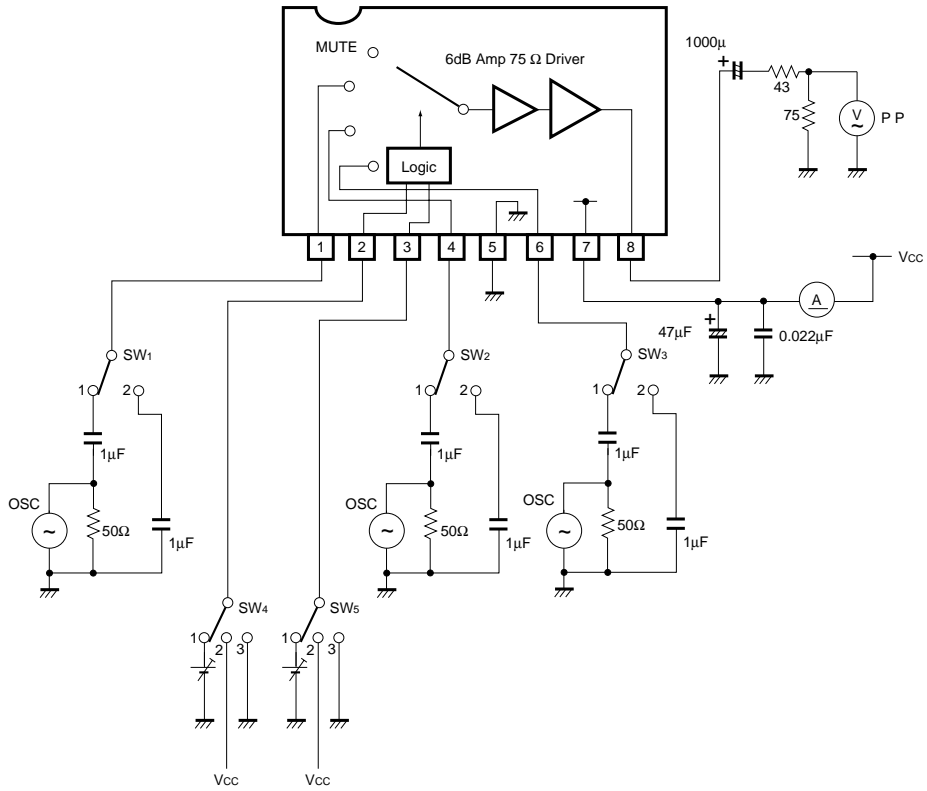

Fig. 1

●Measurement conditions

Parameter		Symbol	Switch settings					Measurement method
			SW ₁	SW ₂	SW ₃	SW ₄	SW ₅	
Current dissipation		I _{CC}	2	2	2	2	2	Ammeter
Maximum output level	IN ₁	V _{om}	1	2	2	3	3	f = 1kHz THD = 0.5% *1
	IN ₂	V _{om}	2	1	2	3	2	
	IN ₃	V _{om}	2	2	1	2	3	
Voltage gain	IN ₁	G _V	1	2	2	3	3	f = 1MHz, V = 1V _{P-P} *2
	IN ₂	G _V	2	1	2	3	2	
	IN ₃	G _V	2	2	1	2	3	
Interchannel crosstalk	IN ₁ →IN ₂	C _T	1	2	2	3	2	f = 4.43MHz, V = 1V _{P-P} *3
	IN ₁ →IN ₃	C _T	1	2	2	2	3	
	IN ₁ →MUTE	C _T	1	2	2	2	2	
	IN ₂ →IN ₃	C _T	2	1	2	2	3	
	IN ₂ →MUTE	C _T	2	1	2	2	2	
	IN ₃ →MUTE	C _T	2	2	1	2	2	
Frequency characteristic	IN ₁	G _f	1	2	2	3	3	f = 10MHz / f = 1MHz, V = 1V _{P-P} *4
	IN ₂	G _f	2	1	2	3	2	
	IN ₃	G _f	2	2	1	2	3	
CTL pin switching level	CTLa	V _{TH}	2	2	1	1	3	*5
	CTLb	V _{TH}	2	1	2	3	1	

*1: Connect a distortion meter to the output, and input a f = 1kHz sine wave. Adjust the input level until the output distortion is 0.5%.

This output voltage at this time multiplied by 2 is the maximum output level V_{om} (V_{P-P}).

*2: Input a 1V_{P-P}, 1MHz sine wave. The voltage gain is given by $G_V = 20 \log (V_{OUT} / V_{IN}) + 6$.

*3: Input a 1V_{P-P}, 4.43MHz sine wave. The interchannel crosstalk is given by $C_T = 20 \log (V_{OUT} / V_{IN})$.

*4: Input 1V_{P-P}, 1MHz and 10MHz sine waves.

The frequency characteristic is given by $G_f = 20 \log (V_{OUT} (f = 10\text{MHz}) / V_{OUT} (f = 1\text{MHz}))$.

*5: Input a 1V_{P-P}, 1MHz sine wave. Reduce the CTL pin voltage from V_{CC}.

The CTL pin switching level (V_{TH}) is the CTL pin voltage at which the V_{OUT} level drops below 20mV_{P-P}.

●Electrical characteristic curves

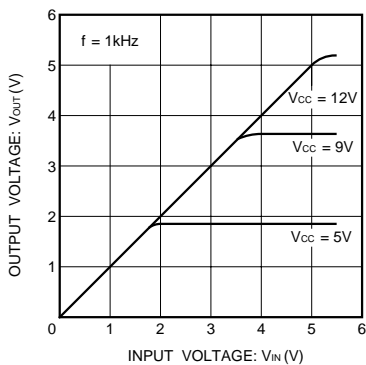

Fig. 2 V_{IN} vs. V_{OUT} characteristics (f = 1kHz)

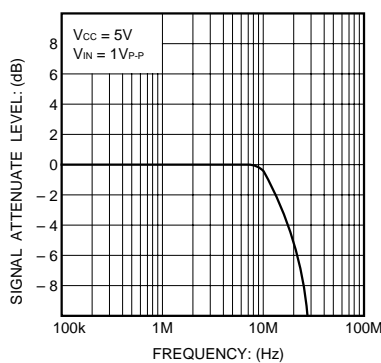

Fig. 3 Frequency characteristics

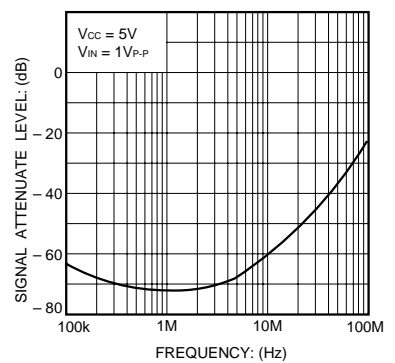
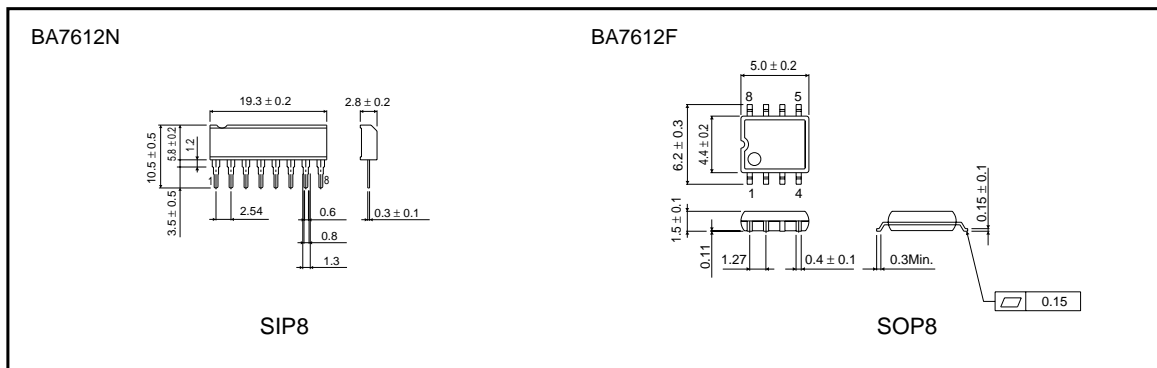

Fig. 4 Interchannel crosstalk

● Operation notes

The output impedance is approximately 32Ω . Therefore, to ensure output matching, connect an external resistor of 43Ω .

● External dimensions (Units: mm)



This datasheet has been downloaded from:

www.DatasheetCatalog.com

Datasheets for electronic components.



LittleDiode supplies new, hard to find or obsolete electronic components and semiconductors all over the world.

With over two million different components listed you are sure to find the part you need.

Feel free to visit us today at our online store:

LittleDiode.com

Looking forward to providing you with the best possible service.